



**CLEMCO**

The Performance System

## TECHNICAL DATA SHEET

*Note: For safe, efficient blasting, read and follow the owner's manual and seek training for everyone who will use this equipment.*

### Purpose

The CMS monitor detects carbon monoxide and hydrocarbons in a compressed air supply and triggers visual and audible alarms when CO is detected in concentrations of 10 parts per million. CMS-1 is wall-mountable; CMS-2 is field-portable with integral rugged carrying case.

NOTE: CMS monitors do not remove CO or convert CO to CO<sub>2</sub>.

### Requirements for Operation

- Compressed-air source (55 to 145 psi) of Grade D breathing air as defined by the Compressed Gas Association commodity specification: G-7.1 ([www.cganet.net](http://www.cganet.net)).
- Air flow of 0.5 to 0.8 scfh at 55 psi or more to operate and maintain adequate sampling
- Power – 120 volt AC or 12 volt DC. Line cord provided for 120 volt AC; may be conduit wired.

### Description of Operation

Connect the CMS to the air supply and to an electric power source. The system warms up and stabilizes in about five minutes.

Once stabilized, the unit is operational and continuously monitors the incoming air. The indicator light glows green to indicate adequate air pressure and flow, and that the CO concentration is below 10 ppm. The alarm light glows yellow, and a loud, intermittent alarms sounds if air flow or pressure drops.

The air-quality light turns red and the CMS sounds a loud, constant alarm if CO reaches 10 ppm. To prevent CO poisoning, the operators must immediately remove their respirators and exit the blast environment.

Once the source of CO has been located, and corrected, the CMS will continue to monitor the air and will glow green automatically when the CO has passed out of the air supply.

## Description

Carbon monoxide monitor and alarm for breathing air supplied from a compressed air source. Features warning lights, high-decibel audible alarm, particulate/oil filter, and connections for optional remote alarm and shutdown devices. Unit monitors air supply; can serve multiple respirators.



Model CMS-2 Field-Portable

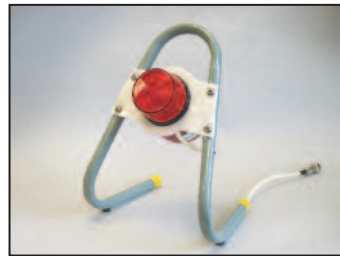

CMS Remote Alarm



Model CMS-1 Wall-Mountable

# CMS Series Carbon Monoxide Alarms

**Model CMS-1 Wall-Mountable, with Calibration Kit:  
Stock No. 23017**

**Model CMS-2 Field-Portable, with Calibration Kit:  
Stock No. 22894**

### Advantages

- One monitor can serve multiple respirators
- Microprocessor circuit and digital readout provide accurate readings
- Simple, rugged construction for in-plant or field use
- Manual calibration accomplished in minutes
- Long-lasting replaceable sensor
- May be used with 120 volt AC or 12 volt DC power source
- Accommodates optional remote alarm kit

### Approvals and Certifications

- Meets OSHA requirement for CO monitoring

### Specifications

- Shielded to reject radio frequency interference
- Includes 10 feet of 1/8-inch tubing and connector fittings
- Electrochemical sensor responds instantly to CO
- CMS-1 has polycarbonate case with impact-resistant clear plastic cover meets NEMA-4 specifications
- CMS-2 has polyethylene case with dual hinges, dual latches, and dust-tight, weather-resistant rubber seal
- Nominal noise rating of 98 dB at distance of one foot for the standard alarm; and 100 dB at distance of 3.1 feet for the optional remote alarm.

### Options and Accessories

- Humidifier .....Stock No. 03600
- Remote alarm kit includes: remote alarm, stand, wiring connector, and 50-ft. cord.....Stock No. 22909
- Remote alarm extension cord .....Stock No. 22910

## Related Clemco Literature

### Description

	Stock No.
Operator Safety Equipment .....	07764
CMS-1 Owners Manual .....	23301
CMS-2 Owners Manual .....	22925

## Replacement Parts

### Item Description

	Stock No.
(-) CMS-1 CO monitor package, includes: monitor, calibration connector, and 10 PPM test gas .....	23017
1. CMS-1 CO monitor includes: monitor and items 3 to 9 .....	23012
2. Calibration connector assembly .....	23011
3. Test gas 10 PPM .....	22865
Test gas, impurity free .....	11132
4. Regulator /Filter .....	23013
5. Flowmeter .....	21376
6. Horn w/ wire, 12 Volt DC .....	22922
7. Adaptor, straight, 1/8" NPT x 1/8" barb .....	11732
8. Adaptor, elbow, 1/8" NPT x 1/8" barb .....	11733
9. Tubing, urethane, per foot .....	12475
10. Reducer, 1/4" x 1/8" .....	02026
(-) Sensor (not shown) .....	23015
(-) Filter element (not shown) .....	23014

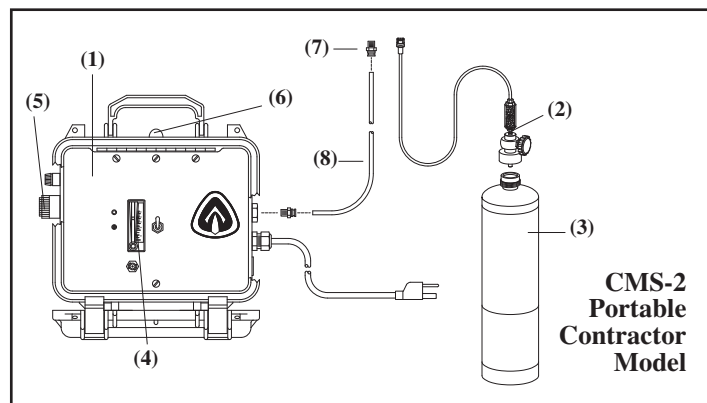
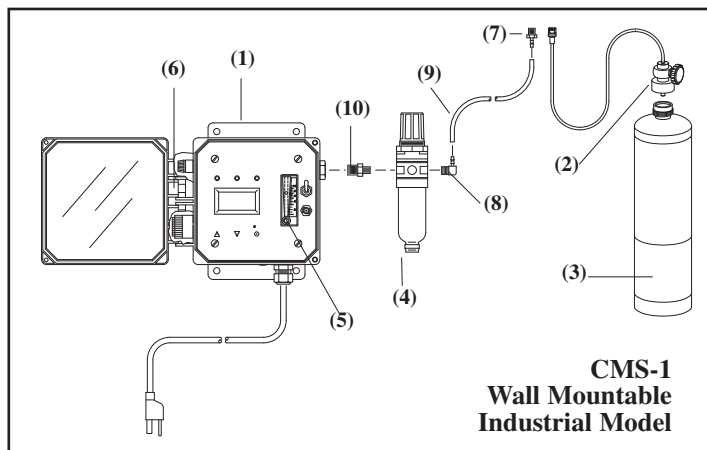

**Color:** CMS-2: black case w/ white graphic front  
 CMS-1: gray metal enclosure w/ white graphic front  
 Optional Remote Alarm: gray metal

## Item Description

## Stock No.

(-) CMS-2 CO monitor/alarm package, includes: monitor, calibration connector, and 10 PPM test gas.	
120 V AC .....	22894
12 V DC .....	25024
1. CMS-2 CO monitor/alarm (instrument only) .....	22892
120 V AC .....	22892
12 V DC .....	25072
220 V AC .....	25532
2. Calibration connector assembly .....	22893
3. Test gas 10 PPM .....	22865
Test gas, impurity free .....	11132
4. Flowmeter .....	21376
5. Horn w/ wire, 12 Volt DC .....	22922
6. Alarm light, exterior w/ wire .....	22923
7. Fitting, 1/4" OD, quick fit .....	22924
8. Tubing, urethane, per foot .....	12475
(-) Sensor (not shown) .....	22919
(-) Regulator/filter (not shown) .....	22920
(-) Filter element (not shown) .....	22921
(-) Air-line humidifier .....	03600

## Optional Remote Alarm

(-) Remote Alarm: includes: alarm, stand, wiring connector and 50 ft. cord .....	22909
1. Cable, remote alarm extension 50 feet .....	22910
2. Strobe light .....	22984
3. Horn .....	22985
4. Wiring adaptor .....	22986
5. Stand assembly with internal wiring .....	22987

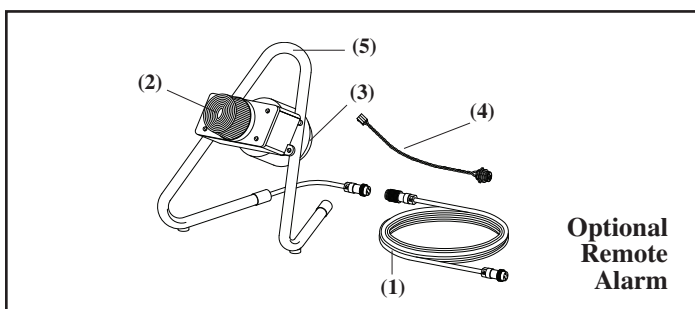

**Packaging:** Ships in one carton with owner's manual.

## Stock No. Dimensions Shipping Wt.

23017	7-1/2" H x 7 1/2" W x 5-1/2" D	8 lb
23012	7-1/2" H x 7 1/2" W x 5-1/2" D	6 lb
22894	9-1/4" H x 10 3/8" W x 5" D	9 lb
22892	9-1/4" H x 10 3/8" W x 5" D	7 lb

Authorized Distributor:

# CANFIELD & JOSEPH

[www.canfieldjoseph.com](http://www.canfieldjoseph.com)

800-364-5452

ISO 9001:2008 certified. Clemco is committed to continuous product improvement. Specifications are subject to change without notice.

© 2012 Clemco Industries Corp. • One Cable Car Drive • Washington, MO 63090 • Phone (636) 239-4300 • Fax (800) 726-7559

Stock No. 23248

[www.clemcoindustries.com](http://www.clemcoindustries.com)

0901 Rev. C, 11/12