

Abrasive Blasters 1.5 - 20 cu. ft (MV2)

OPERATION AND MAINTENANCE MANUAL

MARCH 2015

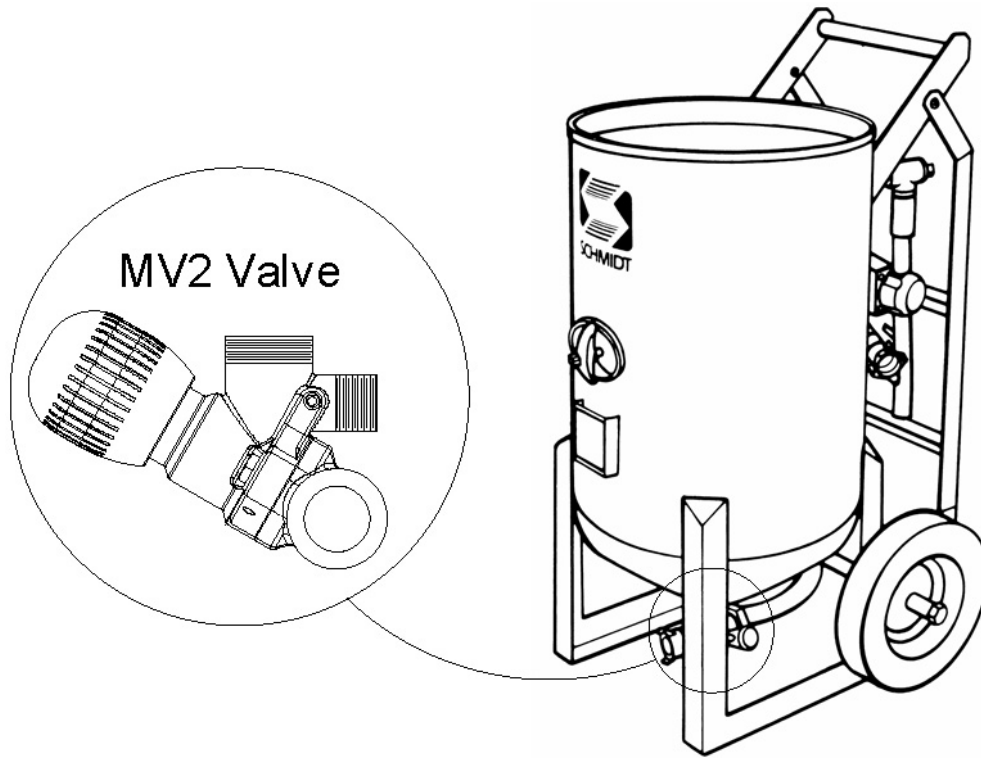

SCHMIDT®

SAVE THIS MANUAL AND MAKE AVAILABLE
TO ALL USERS OF THIS EQUIPMENT!

Manual Part Number 7200-200MV
(available for downloading from SchmidtAbrasiveBlasting.com)



Copyright © 2015 AXXIOM Manufacturing, Inc.
11927 S. Highway 6, Fresno, Texas 77545
800.231.2085 * 281.431.0581 * fax 281.431.1717



Visit us at www.SchmidtAbrasiveBlasting.com

WARNING

- 1. Any person intending to operate this equipment or any person intending to be in the vicinity during its operation must receive proper training from his/her supervisor, employer and/or supplier. If this equipment is to be leased or rented, the supplier must assure that the lessee or renter has received proper training before the lessee or renter takes possession of the equipment. Consult Axxiom Manufacturing, Inc.**
- 2. Any person authorized to operate this equipment or any person intending to be in the vicinity during its operation and who is not capable of reading and understanding this manual must be fully trained regarding the *Rules for Safer Operation* and all operating procedures, and must be made aware of all the Dangers, Warnings, and Cautions identified herein. Consult Axxiom Manufacturing, Inc.**
- 3. Do Not operate any abrasive blaster or blast equipment before reading and completely understanding all the warnings, operating procedures and instructions, and the *Rules for Safer Operation* contained in this manual.**
- 4. Do Not operate any abrasive blaster or blast equipment without following the *Rules for Safer Operation* and all the operating procedures and instructions. Failure to properly use blast equipment could result in serious injury or death.**
- 5. Do Not perform any maintenance on any abrasive blaster or blast equipment while it is pressurized. Always depressurize the abrasive blaster vessel before loading abrasive or performing any maintenance.**
- 6. Do Not use abrasives containing free silica. Silica can cause silicosis or other related respiratory damage. All operators must wear personal protective equipment for all abrasive blasting operations. Observe all applicable local, state and federal safety regulations in conjunction with airline filters and respiratory protection. Reference OSHA 29 CFR 1910.134.**
- 7. Do Not enter areas during abrasive blasting operations without breathing protection. All personnel in the vicinity of abrasive blasting operations should wear NIOSH approved air fed respirators, hoods or helmets.**
- 8. Do Not modify or alter any abrasive blaster, blast equipment or controls thereof without written consent from Axxiom Manufacturing, Inc.**
- 9. Do Not use bleeder type deadman valves on any Schmidt® abrasive blaster. The use of A-BEC, Clemco or a similar bleeder type deadman valve can cause unintentional start-up without warning, which can result in serious personal injury.**
- 10. Do Not sell, rent, or operate abrasive blasters without remote controls. OSHA regulations require remote controls on all blast machines. Failure to use remote controls can cause serious injury or death to the operator(s) or other personnel in the blasting area. Reference OSHA 29 CFR 1910.244(b).**
- 11. Do Not repair or replace any portion of Schmidt® equipment using components that are not Schmidt® original factory replacement parts. Use of replacement components that are not Schmidt® original factory replacement parts may result in equipment failure which can result in serious personal injury and in addition will void all warranties.**

Instructions for use of manual sections

This manual contains information needed to operate and maintain a Schmidt® abrasive blaster. Read this entire operations and maintenance manual before using the abrasive blaster. Pay close attention to the *Rules for Safer Operation* (Section 1.0), and the Dangers, Warnings, and Cautions identified.

The purpose of safety symbols and explanations are to alert operators of the possible hazards and explain how to avoid them. The safety symbols and explanations do not by themselves eliminate any danger. However, following the instructions given and taking proper accident prevention measures will greatly lower the risk of injury to personnel. Below are the three hazard levels as used in this manual.



WHITE LETTERS with RED BACKGROUND

DANGER: Indicates an imminently hazardous situation that, if not avoided, will result in death or serious injury. This signal word is limited to the most extreme situations.



BLACK LETTERS with ORANGE BACKGROUND

WARNING: Indicates a potentially hazardous situation that, if not avoided, could result in death or serious injury.



BLACK LETTERS with YELLOW BACKGROUND

CAUTION: Indicates a potentially hazardous situation that, if not avoided, may result in minor or moderate injury. It may also be used to alert against unsafe practices that may cause property damage.

This manual contains terms that may be specific to the abrasive blast industry. Understanding these terms will help operators understand the procedures and instructions given in this manual. All operators must be familiar with the following terms and refer to them as needed while reading this manual.

Term	Definition
Pressure Vessel	A fabricated tank (or reservoir) that is part of the abrasive blaster which is filled with compressed air and abrasive. (Also referred to as “blast vessel” or “vessel”.)
Pressurize	To manually or automatically fill the abrasive blast vessel with compressed air.
Depressurize	To manually or automatically release all the compressed air from inside the abrasive blast vessel. (Also referred to as “blowdown”.)
Depressurized System	An abrasive blaster that is pressurized only when the deadman activates the blast operation. The blaster automatically depressurizes when the deadman is released.
Pressurized System	An abrasive blaster that is automatically pressurized when the air inlet ball valve is opened. The blaster remains pressurized when the deadman is released.
Blowdown	To manually or automatically release all the compressed air from inside the abrasive blast vessel. (Also referred to as “depressurize”.)
Deadman	A manually operated valve or switch that allows remote starting and stopping of the blast operation. [Also referred to as “deadman valve” (pneumatic blast controls) or “deadman switch” (electric blast controls.)]
Popup	An air pressure operated valve that seals the abrasive inlet at the top of the pressure vessel. Its operation may be manual or automatic.
Abrasive	A granular substance used in an air blast operation that is the means for blasting the surface of an object. (Also referred to as abrasive blasting media.)
Silica	The crystalline chemical compound silicon dioxide (SiO ₂) which can be found in many natural abrasives and other substances. Breathing silica dust can cause respiratory diseases such as silicosis. (Also referred to as crystalline silica)

0.0 Warning Decal Identification and Location

Listed below are the warning decals and the corresponding hazards related to this equipment. Refer to Figure 0.1(a) and 0.1(b) for images of the warning decals. Refer to Figure 0.2(a) and 0.2(b) for the locations of these warning decals on the abrasive blaster.

No.	Qty.	Part no.	Description	Hazard
1.	1	7031-001	Medium “Schmidt”	Not Applicable
2.	1	7031-054	“Warning” Airborne particle and loud noise hazard.	Airborne particles and loud noise from blast nozzle and blowdown can cause injury and loss of hearing. Wear approved eye and ear protection. See Sections 1.0 and 3.10.
3.	1	7031-007B	“Danger” Pressurized vessel.	Propelled objects will cause serious injury or death. Depressurize vessel prior to performing any maintenance. See Section 6.2.
4.	1	7031-057	“Warning” Read manual before using this machine.	Read and understand operator’s manual before using this machine. Failure to follow operating instructions could result in injury or damage to equipment. See Section 1.0.
5.	1	7031-077	“Warning” Pinch point hazard.	Vessel pressurization will close popup. Closing popup can pinch and crush. Keep hands and fingers away from popup.
6.	1	7031-082	“Danger” Pressurized vessel Handway components.	Propelled objects will cause serious injury or death. Incorrect or damaged handway or manway cover components can result in failure. See Section 6.3.
7.	1	7034-001	Welded “Warning” plate General hazard and advisory notes.	Steel “Warning” plate welded to pressure vessel which is a general list of required actions to take before and during the operation of this equipment. See Section 1.0.



1) 7031-001



2) 7031-054

Figure 0.1(a) – Warning decal summary



3) 7031-007B



4)7031-057



5) 7031-077



6) 7031-082

WARNING

1. TO PREVENT INJURY OR DEATH, READ WARNINGS AND SAFE PROCEDURES IN OWNER'S MANUAL

2. DEPRESSURIZE UNIT BEFORE ANY MAINTENANCE OR LOADING

3. TO PREVENT DELAYED LUNG INJURY, DO NOT USE ABRASIVES CONTAINING FREE SILICA.

4. FURNISH ALL PERSONNEL IN THE AREA WITH N.I.O.S.H. APPROVED RESPIRATORY EQUIPMENT AND EAR PLUGS.

5. FAILURE TO PROPERLY USE BLASTING EQUIPMENT COULD RESULT IN SILICOSIS AND DEATH.

7) 7034-001

Figure 0.1(b) – Warning decal summary (continued)

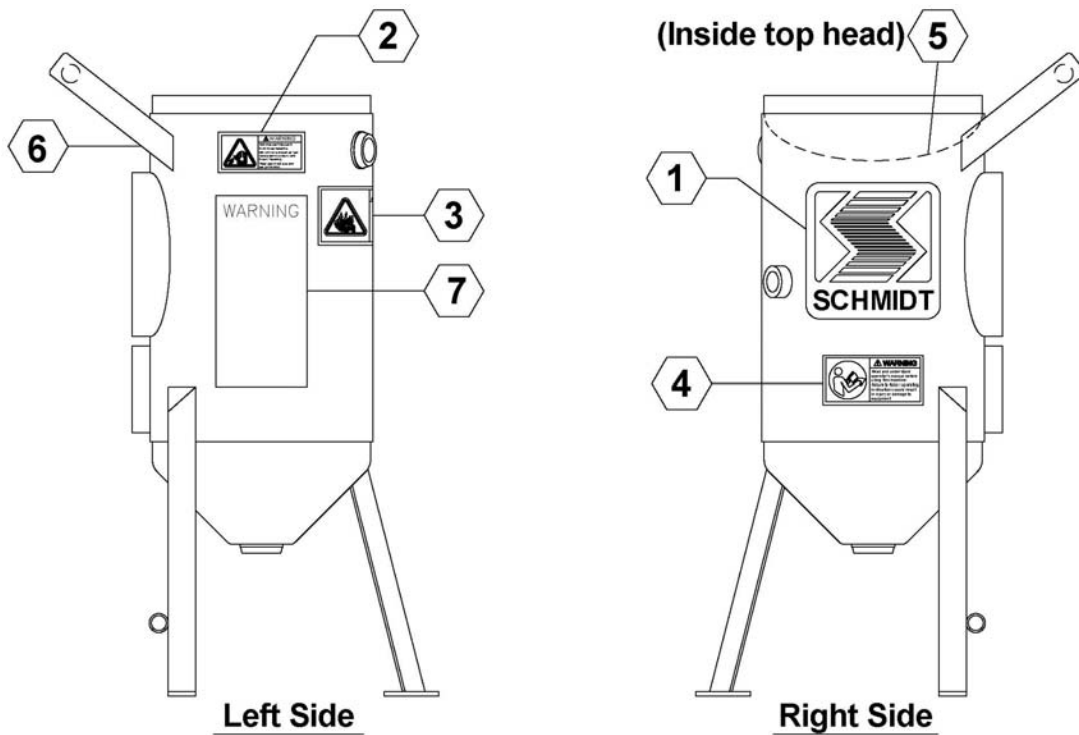

Figure 0.2(a) – Warning decal placement (1.5 cu. ft.)

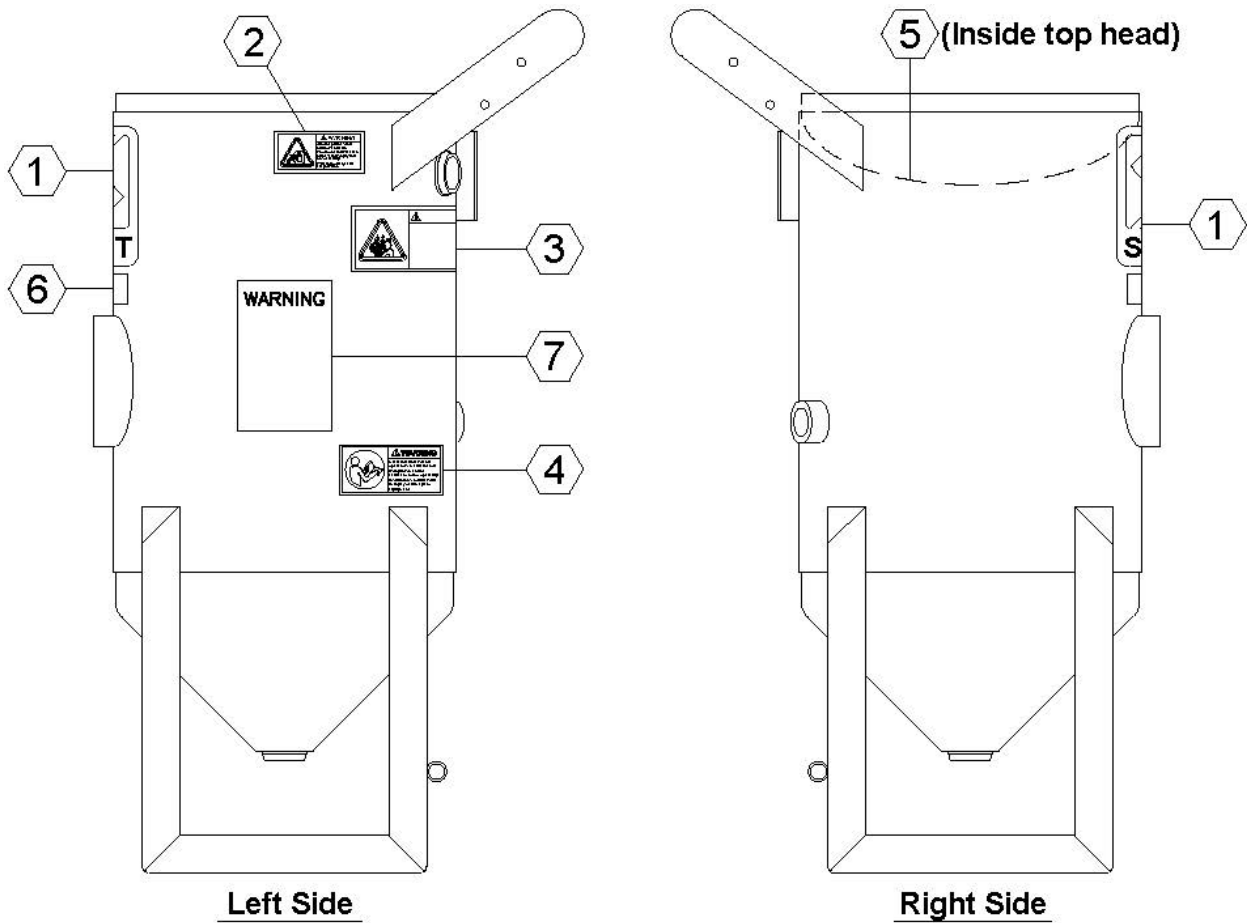

Figure 0.2(b) – Warning decal placement (3.5 - 20 cu. ft.)

Table of Contents

Section		Page
0.0	Warning Decal Identification and Location	4
1.0	Rules for Safer Operation	8
2.0	Specifications and General Information	15
3.0	Installation Requirements and Personal Protective Equipment	19
4.0	Abrasive Blast System General Operation	25
5.0	MV2 Blast System General Operation	26
6.0	Pre-operation Procedures	33
7.0	Operating Instructions	38
8.0	Maintenance and Inspection Instructions	42
9.0	Drawings and Parts Lists	47
10.0	Recommended Spare Parts Lists	63
11.0	Troubleshooting	64
12.0	Warranty and Reference Information	67
13.0	Blasting Data Tables	Back Cover

1.0 Rules for Safer Operation

1.1. GENERAL RULE FOR SAFER OPERATION.

SCHMIDT® ABRASIVE BLASTERS HAVE BEEN DESIGNED TO BE SAFE WHEN USED IN THE PROPER MANNER. ALL ABRASIVE BLASTERS ARE POTENTIALLY DANGEROUS IF ALL SAFETY PRECAUTIONS ARE NOT RIGOROUSLY FOLLOWED. PROPER TRAINING IS REQUIRED BEFORE OPERATION. PROPER PROCEDURES MUST BE FOLLOWED. THE ABRASIVE BLASTER AND ALL COMPONENTS MUST BE PROPERLY MAINTAINED. FAILURE TO OPERATE, SERVICE AND MAINTAIN THE ABRASIVE BLASTER AS SET FORTH IN THIS MANUAL MAY CAUSE INJURY OR EVEN DEATH TO ANY PERSON USING, SERVICING OR IN THE VICINITY OF THE ABRASIVE BLASTER.

THIS MANUAL IDENTIFIES POTENTIAL HAZARDS BY DANGER, WARNING, AND CAUTION SYMBOLS. HOWEVER, ALL THE RULES, PROCEDURES AND RECOMMENDATIONS MUST BE FOLLOWED. FAILURE TO OPERATE PROPERLY IS VERY LIKELY TO PLACE PERSONS AND PROPERTY AT HIGH RISK OF DAMAGE, INJURY OR EVEN DEATH.



ABRASIVE BLASTERS AND THE ABRASIVE BLAST OPERATION ARE POTENTIALLY DANGEROUS IF ALL SAFETY PRECAUTIONS ARE NOT FOLLOWED. FAILURE TO OPERATE THE ABRASIVE BLASTER WITHOUT FOLLOWING ALL THE *RULES FOR SAFER OPERATION* MAY RESULT IN SERIOUS INJURY OR DEATH TO OPERATING PERSONNEL OR PERSONS IN THE OPERATING VICINITY.

1.2. KNOW YOUR EQUIPMENT.

Do Not operate this equipment in a manner other than its intended application (see Section 4.0). Do Not operate this equipment or any other Schmidt® equipment without following the *Rules for Safer Operation* and all the operating procedures and instructions. Learn the applications and limitations as well as the specific potential hazards related to this machine. Failure to do so could result in serious injury or death.

1.3. RECEIVE PROPER TRAINING.

Do Not operate this equipment unless you have received operational and maintenance training. Begin by thoroughly reading and understanding this operation and maintenance manual and all included information. Consult an authorized Schmidt distributor or Axxiom manufacturing, Inc.

1.4. PROTECT YOUR FEET.

Do Not operate this equipment without wearing OSHA approved foot protection. Observe all applicable local, state and federal regulations. See Section 3.10 and OSHA 29 CFR 1910.136.



Heavy objects can shift while being blasted and may fall on operators. All operators and personnel in the vicinity must wear OSHA approved foot protection during the operation of this equipment. See Section 3.10 and OSHA 29 CFR 1910.136.

1.5. PROTECT YOUR EYES.

Do Not operate this equipment without wearing OSHA approved safety glasses. Observe all applicable local, state and federal safety regulations. See Section 3.10 and OSHA 29 CFR 1910.133.



When filling the blast vessel and during the blast operation, abrasive can be blown in the face and eyes of operators. All operators and personnel in the vicinity must wear OSHA approved safety glasses during the operation of this equipment. See Section 3.10 and OSHA 29 CFR 1910.133.

1.6. PROTECT YOUR LUNGS.

Do Not operate this equipment without wearing OSHA approved respiratory protection. Abrasive blasting produces dust contaminated with toxic substances from the abrasive used, the coating being removed, and the object being blasted. This dust may contain silica which can cause severe and permanent lung damage, cancer, and other serious diseases. Do Not breathe the dust. Do Not rely on your sight or smell to determine if dust is in the air. Silica and other toxic substances may be in the air without a visible dust cloud. If air-monitoring equipment for silica is not provided at the worksite, then all personnel **MUST** wear appropriate respiratory protection when using or servicing this equipment. Breathing air supplied to respirators must be of acceptable quality. Consult your employer and OSHA regarding the appropriate respiratory protection and breathing air quality. See Sections 3.9, 3.10, and OSHA 29 CFR 1910.134.



Abrasive blasting produces dust which may contain silica and other toxic substances that can cause severe and permanent lung damage, cancer, and other serious diseases if inhaled. All operators and personnel in the vicinity must wear OSHA approved respiratory protection during the operation of this equipment. See Sections 3.9, 3.10, and OSHA 29 CFR 1910.134.

1.7. BREATHING AIR QUALITY.

Do Not use breathing air that does not meet OSHA Class D standards. Use extreme caution when selecting a source of breathing air. Breathing air provided by an oil-lubricated air compressor can contain carbon monoxide; therefore, use of a carbon monoxide detector is required (See Section 3.10). Carbon monoxide can be in the compressed air produced by an oil-lubricated air compressor when it is operated at extremely high temperature; therefore a high temperature alarm is required to alert the operators when this condition exists. See Section 3.9 and reference OSHA 29 CFR 1910.134(i).

Extreme caution must be taken when connecting to factory air sources. Factories can have sources of compressed gases such as nitrogen which is fatal if used as a breathing air source. Verify that the air source is breathable air.



Breathing air must meet OSHA Class D standards. Use of breathing air sources that do not meet Class D standards can cause asphyxiation and result in death. Verify that all air sources are breathable quality and use a high-temperature alarm and a carbon monoxide monitor when required. See Sections 3.9, 3.10 and OSHA 29 CFR 1910.134(i).

Enclosed blast areas must be ventilated to reduce airborne dust to an acceptable level as required by OSHA 29 CFR 1910.1000.

1.8. PROTECT YOUR HEARING.

Do Not operate this equipment without wearing OSHA approved hearing protection. Observe all applicable local, state and federal safety regulations. See Section 3.10 and refer to OSHA 29 CFR 1910.95.



Loud noise is produced by the blast nozzle and the blowdown operation of this equipment. All operators and personnel in the vicinity must wear OSHA approved hearing protection during the operation of this equipment. See Section 3.10 and refer to OSHA 29 CFR 1910.95.

1.9. PROTECT YOUR PERSON

Abrasive blasting produces dust contaminated with toxic substances from the abrasive used, the coating being removed, and the object being blasted. All blast operators and other personnel involved in the blast operation or in the vicinity of the blast operation should wear protective clothing. The protective clothing should be disposable or washable work clothes that should be removed at the worksite so that contaminated dust is not transferred into automobiles or homes. See Section 3.10 and refer to OSHA 29 CFR 1910.94 and 1910.134.

1.10. ADHERE TO ALL REGULATIONS.

Do Not operate this equipment without observing all local, state, and federal safety regulations including, but not limited to, OSHA (Occupational Health and Safety Administration).

1.11. STAY ALERT.

Do Not operate this equipment when you are tired or fatigued. Use caution and common sense while operating and/or performing maintenance on this equipment.

1.12. DO NOT USE DRUGS, ALCOHOL, or MEDICATION.

Do Not operate this equipment while under the influence of drugs, alcohol, or any medication.

1.13. PROTECT BYSTANDERS.

Do Not allow blast equipment operators and other personnel to enter the vicinity of the blast operation without providing respiratory protective equipment that meets OSHA regulations. If dust concentration levels exceed the limitations set in OSHA 29 CFR 1910.1000 then respirators are required.

1.14. KEEP CHILDREN AND VISITORS AWAY.

Do Not allow children or other non-operating personnel to contact this equipment or the connecting hoses and cords. Keep children and non-operating personnel away from work area.

1.15. AVOID DANGEROUS ENVIRONMENTS.

Do Not operate this equipment without familiarizing yourself with the surrounding environment. The blast operation creates high level of noise which may prevent the operator from hearing other possible dangers (i.e. traffic or moving equipment). In such situations a stand-by watch person may be necessary to protect against injury to personnel.

1.16. AVOID DANGEROUS ENVIRONMENTS.

Do Not use this equipment in areas cluttered with debris. Debris in the work area can create tripping hazards which can cause the operator to loose control of the blast hose and result in injury to operating personnel. Keep work area clean and well lit. When working at an elevated location, pay attention to articles and persons below.

1.17. AVOID DANGEROUS ENVIRONMENTS.

Do Not operate this equipment in elevated areas without using fall protection equipment. Certain applications of this equipment may require the use of scaffolding. Use of scaffolding creates hazardous situations such as tripping and fall hazards which can result in serious injury or death to operating personnel. Consult OSHA 29 CFR 1910 Subpart D.

1.18. AVOID DANGEROUS ENVIRONMENTS.

Do Not blast objects that are not properly secured. The blast operation can cause the blasted object to shift or move. Extremely large objects to be blasted can create a crush hazard to operating personnel which can result in serious injury or death. Properly secure the object to be blasted.

1.19. AVOID DANGEROUS ENVIRONMENTS.

Do Not blast objects used to store flammable materials. The blast operation can cause sparks which can ignite fumes or residual flammable materials inside enclosed containers which can explode resulting in serious injury or death to operating personnel.

1.20. ELECTRICALLY GROUND EQUIPMENT.

Static electricity is generated by the abrasive flow through the blast hose. To minimize the chance of static electrical shock to operating personnel only use static dissipating blast hose and install a grounding strap on the abrasive blaster. See Section 5.10.

1.21. MAINTAIN VESSEL INTEGRITY.

Do Not operate this equipment with the pressure vessel damaged, or with any part of it worn or damaged. Do Not operate this equipment in a condition that may cause failure of the pressure vessel. See Sections 1.22 through 1.32 below.



An abrasive blaster is a Pressurized Vessel. Alterations, damage, or misuse of the pressure vessel can result in rupturing. Damaged or incorrect components used on the abrasive blaster can result in rupturing. The compressed air inside a pressurized vessel contains a dangerously high level of energy which can propel objects and cause serious injury or death.

1.22. NEVER OPERATE OVER MAXIMUM WORKING PRESSURE.

Do Not operate this equipment above maximum allowable working pressure (MAWP) at maximum operating temperature (°F) shown on the ASME nameplate attached to the vessel. See Sections 2.2 and 8.1.

1.23. INSTALL PRESSURE RELIEF DEVICE.

Do Not operate this equipment without a pressure relief device in place. The ASME Code requires that all vessels be equipped with pressure relief devices prior to installation. The pressure relief device must be set at the maximum allowable working pressure of the abrasive blaster. See the ASME nameplate attached to the vessel typically located above the handway. See Section 3.11 for information regarding the pressure relief valve.

1.24. NEVER OPERATE BEYOND ALLOWABLE TEMPERATURE RANGE.

Do Not operate this equipment above the maximum allowable temperature at the allowable pressure or below the minimum design metal temperature (MDMT) shown on the pressure vessel nameplate. The characteristics of the pressure vessel metal are weakened when the temperature is outside the operating range. Operating the pressure vessel outside of allowable temperature range can result in rupturing and cause serious injury or death.

1.25. ASME NAMEPLATE REQUIRED.

Do Not operate this equipment if the ASME pressure vessel nameplate is missing. Contact Axxiom Manufacturing, Inc. for technical support.

1.26. DO NOT MODIFY VESSEL.

Do Not modify or alter any abrasive blaster, blast equipment, or controls thereof without written consent from Axxiom Manufacturing, Inc. Do Not weld, grind, or sand the pressure vessel. *It will not be safe to operate.* Non-authorized modifications could lead to serious injury or death. Non-authorized modifications will void the warranty and may void the ASME/NB integrity.

1.27. DO NOT HAMMER ON VESSEL.

Do Not hammer on or strike any part of the pressure vessel. Hammering on the pressure vessel can create cracks and cause rupturing.

1.28. FIRE DAMAGE NOTICE.

Do Not operate if the pressure vessel has been damaged by fire. If damaged, take out of service immediately and have it inspected and/or repaired by a qualified facility. Contact Axxiom Manufacturing, Inc. for technical support.

1.29. INSPECT VESSEL REGULARLY.

Do Not operate this equipment with damage to the pressure vessel. *It is not safe.* Inspect outside and inside of the pressure vessel regularly for corrosion or damage (i.e. dents, gouges or bulges). If damaged, take out of service immediately and have it inspected and/or repaired by a qualified facility. Contact Axxiom Manufacturing, Inc. for technical support. See Section 8.0.

1.30. CHECK FOR LEAKS IN VESSEL.

Do Not operate this equipment if there is a leak in the pressure vessel. If leaking, take out of service immediately and have it inspected and/or repaired by a qualified facility. Contact Axxiom Manufacturing, Inc. for technical support.

1.31. INSPECT HANDWAY ASSEMBLY.

Do Not operate the abrasive blaster without first inspecting the handway assembly. To insure proper operation all handway components must be the correct size for the vessel handway opening. See Section 6.3.

1.32. NEVER MODIFY BLOWDOWN.

Do Not connect the blowdown on this equipment onto a common header with any other unit of any description, or any other source of compressed air, without first making sure a check valve is used between the header and this unit. Do Not install this equipment sharing piping with another unit of higher discharge pressure and capacity. A safety hazard could occur in the form of a back-flow condition. Do Not install a muffler or silencer on the blowdown that is not designed for use on abrasive blast equipment it can cause a malfunction and can result in a hazardous condition.

1.33. DEPRESSURIZE VESSEL BEFORE PERFORMING MAINTENANCE.

Do Not remove, repair, or replace any item on this equipment while it is pressurized. Do Not attempt to perform maintenance or load abrasive while this equipment is pressurized or is even capable of being pressurized. This means the inlet ball valve should be closed and the air supply should be shut off or disconnected. Anytime the manual blowdown valve is closed it should be assumed that the abrasive blast vessel is pressurized.



An abrasive blaster is a Pressurized Vessel. The compressed air inside a pressurized vessel contains a dangerously high level of energy which can propel objects and cause serious injury or death. Depressurize vessel before performing any maintenance. See Section 6.2.

1.34. ALWAYS USE REMOTE CONTROLS.

Do Not sell, rent, or operate abrasive blasters without remote controls. OSHA regulations require remote controls on all abrasive blasters. All abrasive blasters must be equipped with automatic (deadman) type remote controls (either pneumatic or electric). Failure to use remote controls can cause serious injury or death to the operator(s) or other personnel in the blasting area. Reference OSHA 29 CFR 1910.244(b).

1.35. NEVER USE BLEEDER TYPE DEADMAN VALVES.

Do Not use bleeder type deadman valves on any Schmidt® abrasive blaster. The use of A-BEC, Clemco, or a similar bleeder type deadman valve can, without warning, cause unintentional start-up which can result in serious personal injury. A particle of dirt from the air hose can plug the bleed hole in the deadman valve and cause the blast outlet to turn on.

1.36. CHECK FOR DAMAGED PARTS.

Do Not use this equipment with damaged components. Periodically check all valves, hoses, fittings, pipe and pipe fittings (internal and external) to confirm that they are in good condition. Repair or replace any component that shows any sign of wear, leakage, or any other damage. See Section 8.0.



Damaged components can fail during operation and result in serious injury or death to operating personnel.

1.37. ALWAYS USE SAFETY PINS ON HOSE COUPLING CONNECTIONS.

Do Not use this equipment without hose coupling safety pins in place and hose whip checks installed on all air and blast hoses. All blast hose couplings and air hose couplings have pin holes that must be safety pinned to protect against accidental disconnections. Accidental hose disconnection can cause serious injury or death. See Sections 5.12 and 8.7.

1.38. ALWAYS USE CORRECT REPLACEMENT PARTS AND ACCESSORIES.

Do Not use replacement parts or accessories that are not rated for pressures equal to or higher than the abrasive blaster's operating pressure. Improper hoses and/or fittings used on, or connected to the abrasive blaster can rupture and cause serious injury or death.

Do Not use replacement parts that are not Schmidt® original factory replacement parts. Non-original parts may not fit properly and can cause equipment damage and/or failure which can result in serious injury to operating personnel. Consult Axxiom Manufacturing, Inc.



Use of replacement components that are not Schmidt® original factory replacement parts may result in equipment failure which can result in serious injury to operating personnel.

1.39. ALWAYS USE CORRECT PRESSURE RATED ACCESSORIES.

Do Not use air reservoirs or moisture separator tanks that are not rated for use in compressed air applications. Air reservoirs and moisture separator tanks larger than 6 inches inside diameter must have an ASME code stamp.



An air reservoir or moisture separator tank is a Pressurized Vessel. The compressed air inside a pressurized vessel contains a dangerously high level of energy which can explode propelling objects and result in serious injury or death to operating personnel. Air reservoirs and moisture separator tanks must be ASME coded tanks.

1.40. NEVER AIM BLAST NOZZLE TOWARDS ANY PERSON.

Do Not aim the blast nozzle towards yourself or any person. A system malfunction or a blocked blast nozzle that clears can trigger accidental start up resulting in injury to personnel.

1.41. NEVER USE ABRASIVE NOT INTENDED FOR BLAST EQUIPMENT.

Do Not use abrasive blast media containing free silica. Silica can cause silicosis or other related respiratory damage. Verify that the abrasive is intended for use in blasting equipment. Personal protective equipment, including airline filters and respirators, must be used for all abrasive blasting operations. Observe all applicable local, state and federal safety regulations. See Sections 3.8, 3.10, and reference OSHA 29 CFR 1910.134.

1.42. CHECK ABRASIVE FOR DEBRIS.

Do Not use blast abrasive that contains trash or other debris. Trash or debris can create a blockage and cause equipment malfunction. Screen recycled abrasive to remove trash.

1.43. STOP OPERATION IMMEDIATELY IF ANY ABNORMALITY IS DETECTED.

Do Not operate this equipment if anything abnormal is seen during operation. Stop operation immediately for inspection. Refer to Section 8.0 for maintenance and inspection details.

1.44. DO NOT OVERLOAD THE LIFT EYES.

Do Not load the lifting eyes above the rated capacity. Do Not lift the blast vessel by any point other than the lifting eyes or designated lift points. Do Not lift the blast vessel while it is pressurized. See Section 2.6.

1.45. DO NOT TRANSPORT BLAST EQUIPMENT LOADED WITH ABRASIVE.

Do Not attempt to roll portable blasters with abrasive inside. The additional weight of the abrasive can cause loss of control of the blaster while moving which can result in injury to operating personnel.

1.46. MAINTAIN WARNING DECALS.

Do Not remove, cover, obstruct, or paint over any warnings, cautions, or instructional material attached. Warning decals must be installed, maintained, and located to be visible and with enough light for legibility. See Sections 0.0 and 8.14.

1.47. SAVE THIS OPERATION AND MAINTENANCE MANUAL.

Refer to this operation and maintenance manual as needed as well as any additional information included from other manufacturers. Never permit anyone to operate this equipment without having him/her first read this manual and receive proper training. Make this manual readily available to all operating and maintenance personnel. If the manual becomes lost or illegible replace it immediately. This operation and maintenance manual should be read periodically to maintain the highest skill level; it may prevent a serious accident.

1.48. SAFETY REFERENCES

See Section 12.4 for safety information sources and contact information. Use these sources to obtain additional information regarding all aspects of blast operation safety.

2.0 Specifications and General Information

2.1 Notes to Distributors and Owners

- 2.1.1. Verify that the deadman, twinline (or cords), and the operation and maintenance manual are included with the abrasive blaster when it is received. Verify that the deadman, twinline (or cords), and the operation and maintenance manual are included with the abrasive blaster when it is delivered to the purchaser.
- 2.1.2. This equipment is intended for knowledgeable and experienced users. No person or persons should be allowed to operate this equipment without first receiving proper training in abrasive blasting operation and use of this equipment.
- 2.1.3. Immediately notify Axxiom Manufacturing, Inc. of any instances of use of this equipment in any manner other than the intended application. See Section 4.0.
- 2.1.4. Only qualified personnel should load and unload this equipment for shipping. Slings or other lifting devices must only be attached to the designated lifting points. See the lifting diagrams shown in Section 2.6.
- 2.1.5. For further information on options and accessories available for Schmidt® abrasive blasters visit the Axxiom website or contact us:

Axxiom Manufacturing, Inc.
11927 South Highway 6
Fresno, Texas 77545
Phone: 1-800-231-2085
Fax: 1-281-431-1717
Website: www.SchmidtAbrasiveBlasting.com

2.2 Abrasive Blaster Operational Specifications

Maximum Working Pressure	125 or 150 psig @ 250°F (see ASME nameplate) All abrasive blasters manufactured after February 2005 are rated for 150 psig standard.
Maximum External Pressure	Not designed for external pressure
Minimum Metal Temperature	-20°F @ 125 or 150 psig (see ASME nameplate)
Air Consumption	See Section 13.0 table 1
Abrasive Consumption	See Section 13.0 table 2
Blast Hose Size	See Section 13.0 table 3
Electrical requirements	See Section 3.7
Abrasive Capacity	1 Bag: 1.0 cu ft 3 Bag: 3.1 cu ft 6 Bag: 5.6 cu ft 10 Bag: 8.8 cu ft 20 Bag: 18.2 cu ft

2.3 Important Reference Numbers

Fill in the Abrasive Blaster model number, serial number, and other information in the blank spaces below. This information will be needed for reference when service, maintenance, or technical support is required.

Blaster Model Number _____

Blaster Serial Number _____ National Board Number _____

Blaster Type: *MV2 Valve* *Thompson Valve* Blaster Piping Size _____

2.4 Vessel Information

- 2.4.1. All pressure vessels used in Schmidt® Abrasive Blasters are manufactured in strict accordance with the provisions of the ASME Code Section VIII, Div. 1.
- 2.4.2. In order to maintain the high level of quality and quality control used in the manufacture of this vessel, it is required that any and all welded repairs to this vessel be performed by a reputable shop holding a National Board “R” Stamp and/or an ASME “U” stamp, depending on state or city law. Welding on the vessel performed by welders not properly qualified per the ASME Code may void the ASME/NB integrity of the vessel.

2.5 Notes

2.6 Abrasive Blaster Lifting Diagrams and Dimensional Specifications



An abrasive blaster is a Pressurized Vessel. The compressed air inside a pressurized vessel contains a dangerously high level of energy which can propel objects and cause serious injury or death. Depressurize vessel and empty of abrasive before lifting, moving, or transporting.

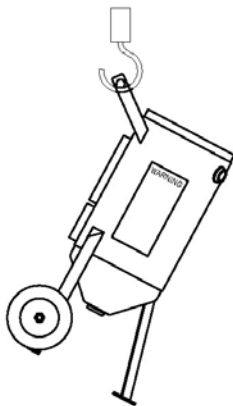

1 BAG PORTABLE

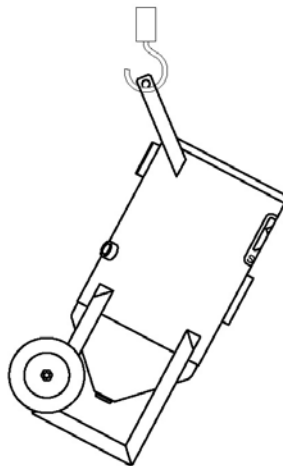

3-10 BAG PORTABLE

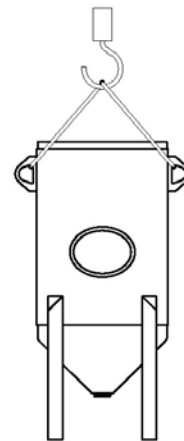

3-20 BAG STATIONARY

NOTE: EMPTY LIFT ONLY. DO NOT LIFT WITH ABRASIVE.

Figure 2.6(a) – Abrasive Blaster Lifting Diagram

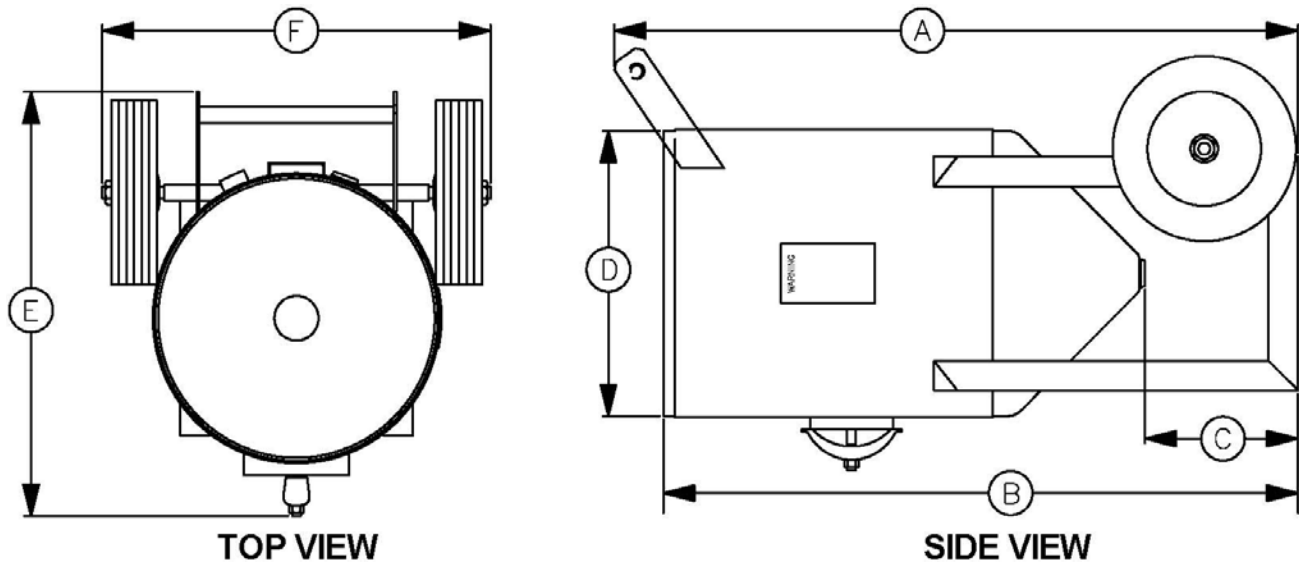

SIZE	CONTROLS	TYPE	A	B	C	D	E	F		WEIGHT	
1.5	MV2 Valve / Combo Valve	PORTABLE	36"	33"	8"	12"	22"	22"	in.	118	lbs.
			(914)	(838)	(203)	(305)	(559)	(559)	(mm)	(54)	(kg)
3.5	MV2 Valve / Combo Valve	PORTABLE	46"	42"	6"	18"	30"	22"	in.	215	lbs.
			(1168)	(1067)	(152)	(457)	(762)	(559)	(mm)	(98)	(kg)
	Thompson Valve II	PORTABLE	49"	45"	9"	18"	30"	22"	in.	217	lbs.
			(1245)	(1143)	(229)	(457)	(762)	(559)	(mm)	(98)	(kg)
	MV2 Valve Union Ball Valve & Thompson Valve II Union Ball Valve	PORTABLE	55"	49"	13"	18"	30"	22"	in.	219	lbs.
			(1397)	(1245)	(330)	(457)	(762)	(559)	(mm)	(99)	(kg)
MV2 Valve / Combo Valve	STATIONARY	-	42"	6"	18"	29"	25"	in.	215	lbs.	
		-	(1067)	(152)	(457)	(737)	(635)	(mm)	(98)	(kg)	
MV2 Valve Union Ball Valve & Thompson Valve II Union Ball Valve	STATIONARY	-	49"	13"	18"	29"	25"	in.	219	lbs.	
		-	(1245)	(330)	(457)	(737)	(635)	(mm)	(99)	(kg)	
6.5	MV2 Valve / Combo Valve	PORTABLE	51"	47"	6"	24"	37"	33"	in.	316	lbs.
			(1295)	(1194)	(152)	(610)	(940)	(838)	(mm)	(143)	(kg)
	Thompson Valve II	PORTABLE	54"	52"	9"	24"	37"	33"	in.	318	lbs.
			(1372)	(1321)	(229)	(610)	(940)	(838)	(mm)	(145)	(kg)
	MV2 Valve Union Ball Valve & Thompson Valve II Union Ball Valve	PORTABLE	58"	54"	13"	24"	37"	33"	in.	320	lbs.
			(1473)	(1372)	(330)	(610)	(940)	(838)	(mm)	(146)	(kg)
MV2 Valve / Combo Valve	STATIONARY	-	47"	6"	24"	35"	31"	in.	316	lbs.	
		-	(1199)	(152)	(610)	(889)	(787)	(mm)	(144)	(kg)	
MV2 Valve Union Ball Valve/ Thompson Valve II Union Ball Valve	STATIONARY	-	54"	13"	24"	35"	31"	in.	320	lbs.	
		-	(1372)	(330)	(610)	(889)	(787)	(mm)	(146)	(kg)	
10	MV2 Valve / Combo Valve	PORTABLE	59"	59"	6"	24"	48"	33"	in.	352	lbs.
			(1499)	(1499)	(152)	(610)	(1219)	(838)	(mm)	(160)	(kg)
	Thompson Valve II	PORTABLE	62"	62"	9"	24"	48"	33"	in.	352	lbs.
			(1575)	(1575)	(229)	(610)	(1219)	(838)	(mm)	(160)	(kg)
	MV2 Valve Union Ball Valve & Thompson Valve II Union Ball Valve	PORTABLE	66"	66"	13"	24"	48"	33"	in.	356	lbs.
			(1676)	(1676)	(330)	(610)	(1219)	(838)	(mm)	(162)	(kg)
MV2 Valve / Combo Valve	STATIONARY	-	59"	6"	24"	35"	31"	in.	352	lbs.	
		-	(1499)	(152)	(609.6)	(889)	(787)	(mm)	(160)	(kg)	
MV2 Valve Union Ball Valve & Thompson Valve II Union Ball Valve	STATIONARY	-	66"	13"	24"	35"	31"	in.	356	lbs.	
		-	(1676)	(330)	(610)	(889)	(787)	(mm)	(162)	(kg)	
20	MV2 Valve Union Ball Valve & Thompson Valve II Union Ball Valve	STATIONARY	-	66"	13"	36"	47"	43"	in.	789	lbs.
			-	(1676)	(330)	(914)	(1194)	(1092)	(mm)	(358)	(kg)

Figure 2.6(b) – Abrasive Blaster Dimensional Data

2.7 Abrasive Blaster Strapping / Packing Detail

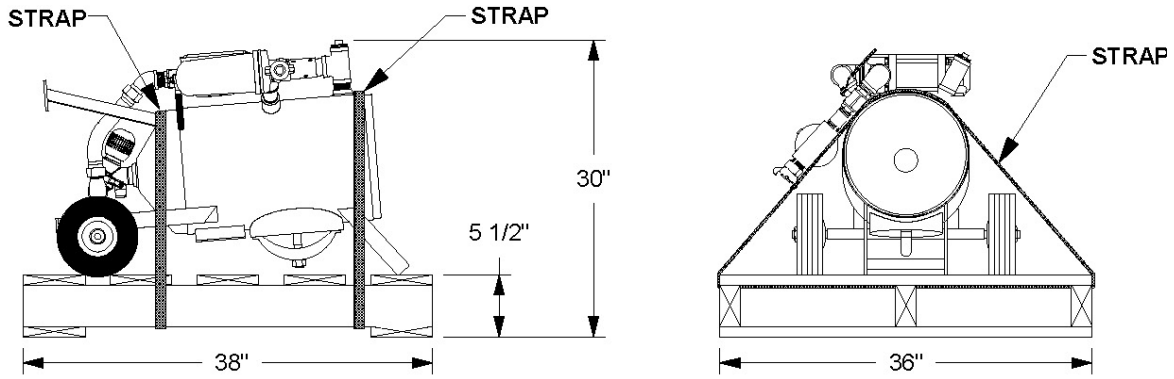

LAY BLASTER AS SHOWN TO PREVENT DAMAGE TO PIPING.
 STRAP BLASTER TO PALLET AS SHOWN. DO NOT STRAP ACROSS PIPING.
 REFER TO SECTION 2.0 FIGURE 2.6(b) FOR BLASTER EMPTY WEIGHT.

FIGURE 2.7(a) - 1.5cf Shipping Detail

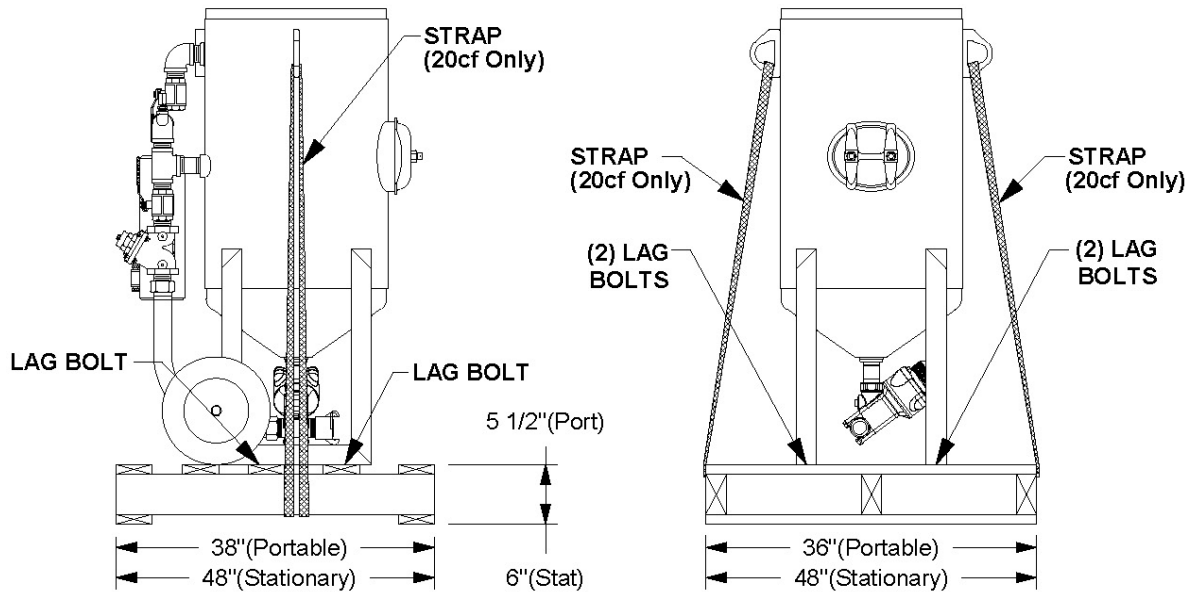

POSITION BLASTER AS SHOWN TO PREVENT DAMAGE TO PIPING.
 LAG BOLT BLASTER TO PALLET AS SHOWN. STRAP BLASTER TO PALLET AS SHOWN.
 REFER TO SECTION 2.0 FIGURE 2.6(b) FOR BLASTER EMPTY WEIGHT.

FIGURE 2.7(b) - 3.5cf, 6.5cf, and 20cf Shipping Detail

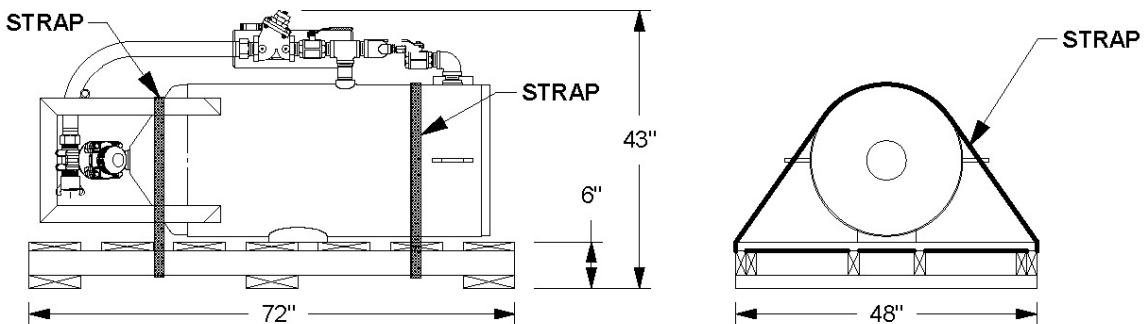

LAY BLASTER AS SHOWN TO PREVENT DAMAGE TO PIPING.
 STRAP BLASTER TO PALLET AS SHOWN. DO NOT STRAP ACROSS PIPING.
 REFER TO SECTION 2.0 FIGURE 2.6(b) FOR BLASTER EMPTY WEIGHT.

FIGURE 2.7(c) - 10cf Shipping Detail

3.0 Installation Requirements and Personnel Protective Equipment

Carefully read and follow all the recommendations regarding the abrasive blast system installation requirements. Improper installation can result in equipment malfunction and significant lost time expenses. Consult an authorized Schmidt® distributor or Axxiom Manufacturing, Inc.

3.1 Abrasive Blast System Installation Location

- i. *Portable units:* Units equipped with handles and wheels are portable and can be rolled to locations where blast jobs are performed. Locate the unit to allow accessibility to the handway and for ease of abrasive filling. Pay close attention to objects that may be in the path of the pressure vessel exhaust air (depressurization). See Section 5.5 for system depressurization.
- ii. *Stationary units:* Units that will be installed in permanent locations require careful consideration. Stationary units can be installed below an abrasive hopper with a support structure that can limit access to the abrasive blast system. Install stationary blast systems in a position that will allow access to the handway and the blaster piping. These areas must be accessible to perform required maintenance. Pay close attention to objects that may be in the path of the pressure vessel exhaust air (depressurization). See Section 5.5 for system depressurization. A longer exhaust hose assembly can be installed on MV2 Blast Systems to direct the exhaust air into the blast room. **Note:** A longer blowdown exhaust hose can lengthen the blowdown time and also presents the possibility of blockage.
- iii. Abrasive blasters 3.5cf and larger are provided with mounting holes in the bottom legs. These holes can be used for securing the blaster to the floor or mounting structure.

3.2 Compressed Air Requirements (blast nozzle)

The blast nozzle size and blast pressure determine the compressed air requirements. Available air flow capacity and/or air compressor size must be considered before selecting the blast nozzle size. An air source dedicated to the abrasive blast system is preferred to reduce system pressure drops and back flow of air. If an existing air compressor will be used or a limited air supply is available, then the blast nozzle must be selected based on these conditions. Be aware that as the blast nozzle wears the air demand will increase. See Table 1 in Section 13.0 for air consumption by nozzle size at various pressures. **Note:** 10cf and 20cf units can be upgraded to two blast outlets and therefore, this option should be considered when determining compressed air requirements.

3.3 Air Compressor Size

Air compressor size is crucial to the operation of the abrasive blast system. Blast nozzle selection and desired productivity must be evaluated to determine the air flow requirements prior to selecting the air compressor size. Sufficient air supply capacity is necessary to maintain the system air pressure. Insufficient air flow capacity will result in reduced blast nozzle pressure and lost productivity. The air compressor must be large enough to supply:

- i. The sum of blast air requirements for each nozzle at the highest pressure that will be used (see Section 13.0, Table 1).
- ii. The 12 CFM breathing air supplied to each blast operator respirator. **Note:** Reference OSHA regulations regarding requirements for breathing air, especially when an oil-lubricated air compressor is used.

3.4 Blast System Air Supply Line

The air supply hose and fittings must be rated at a minimum of 150 psi operating pressure. The air supply hose from the air compressor to the blast unit should be at least the same diameter as the air inlet piping (see Section 9.0). This size hose will be large enough to supply the required airflow to operate the blast unit controls and each blast nozzle. See Section 5.12 for further information on air hose connection.

Note: If the abrasive blast system will be installed in a permanent location, the inlet connection can be hard piped. Do Not install hard piping that is smaller than the piping size of the blast system. Smaller piping size will reduce the air flow capacity. If other equipment will be using the same source of air as the abrasive blaster, install a check valve at the air inlet. This will protect against back flow of air pressure that can carry abrasive into the blast controls.

Hard piping connected to the abrasive blaster must be structurally supported so not to apply any loading on the pressure vessel at the points of connection. Unsupported piping can create bending loads at the connections on the pressure vessel and cause failure. Hard piping connections to the pressure vessel must be designed and installed by qualified personnel experienced with piping systems and the applicable codes pertaining to them.



External loading at piping connection can cause failure of the pressure vessel. Hard piping connected to the pressure vessel must include supports to eliminate the possibility of applying loads on the pressure vessel.

3.5 Blast System Air Pressure

The maximum allowable working pressure (MAWP) for the blast unit is stamped on the ASME nameplate attached to the vessel. For most abrasive blast systems the MAWP is 150psig. Do Not exceed the MAWP. An air pressure regulator can be installed to reduce air supply pressure that is higher than the MAWP. To prevent air pressure backflow only use a non-relieving air regulator. Air pressure backflow will carry abrasive from the blast vessel and contaminate the blast control system. **Critical: Any inlet air valve or air pressure regulator added to the system must have sufficient air flow capacity for proper operation of the blast system. Insufficient air flow capacity will cause pressure drop in the blast system resulting in equipment malfunction, abrasive backflow, and reduced blast productivity. Select a valve that will operate with little or no pressure drop (5 psi max.) at the required cfm air flow.**

Installing an air pressure regulator allows the option of blasting at low pressure. When blasting at low pressure the air supply to the deadman blast control system must be at least 80psig (see Figure 5.3 and 5.4). The valves in the abrasive blast system are “spring closed” and therefore require at least 80psig to operate properly. If the air pressure regulator is set below 80psig the air supply to the blast controls must be taken upstream of the regulator.

3.6 Blast System Air Quality

Air quality is crucial to the operation of an abrasive blaster. Moisture and contaminants can cause components to malfunction. Moisture condensation in a blast system causes abrasive flow problems. Condensation occurs when the hot vapor-filled compressed air cools as it reaches the abrasive blaster. Water droplets formed during condensation can be absorbed by the abrasive in the blast vessel which can cause erratic flow to the abrasive valve. Therefore, a moisture removal device installed for the blast system air supply is recommended (i.e. coalescing moisture separator, air-cooled aftercooler or deliquescent dryer). Contact a local authorized Schmidt® distributor or Axxiom Manufacturing, Inc. to locate one near you.

3.7 Electrical Requirements

On units equipped with electric blast controls the supply voltage is 12Vdc or 24Vac. The maximum power required is:

1-outlet:	7 watts	1-outlet with abrasive cutoff:	14 watts
2-outlet:	14 watts	2-outlet with abrasive cutoff:	28 watts

Note: Insufficient electric power output will result in malfunctioning of the electric blast control system. A power transformer or power supply can be used if the above voltages are not readily available.

3.8 Abrasive Selection

Abrasive selection is likely the most difficult decision related to the blast operation. Choice of abrasive is based on factors such as blast application type, desired finish and coating requirements, characteristics of object to be blasted, cost and ability to recycle, available equipment, safety, and environmental constraints.

There are many abrasives available that are either natural, manufactured, or processing by-products. Abrasives are available in varying sizes, shapes, and hardness. These characteristics determine the resulting effect on the surface to be blasted and limitations of its use. The effects on the blasted surface are measured by its degree of cleanliness and the surface profile. Standards and required levels of these measurements are established by organizations such as Steel Structures Painting Council (SSPC), National Association of Corrosion Engineers (NACE) and coating manufacturers. See Section 12.5 for contact information of these organizations. Use these sources to obtain information regarding all aspects of surface preparation and abrasive selection guidelines.

Schmidt® abrasive blasters are designed for high production open abrasive blasting with a wide range of abrasives. It is the responsibility of the employer and operators to select the proper abrasive. It is the responsibility of the employer to make certain that the abrasive selected is safe to use for abrasive blasting.

Critical: Always obtain the Material Safety Data Sheet (MSDS) for the abrasive to be used. The MSDS provides the chemical makeup of the abrasive. Do Not use abrasives containing toxic materials. Refer to OSHA 29 CFR for acceptable limits of various toxic substances and additional measures to be taken to protect operating personnel. Always use abrasives containing less than 1% of crystalline silica. Always use a NIOSH approved respirator when handling, loading and cleaning up abrasives. Organic substances which are combustible may only be used in automated blast systems with ventilation that meets OSHA 29 CFR 1910.94.

3.9 Breathing Air Quality

All blast operators must be supplied with and required to use NIOSH approved air-fed respirators. Breathing air supplied to these respirators must meet Grade D air quality standards as specified by OSHA 29 CFR 1910.134(i) and the Compressed Gas Association Specifications ANSI/CGA G-7.1. Consult these specifications when selecting a source of breathing air.

Breathing air must be clean, dry, contaminant-free, and provided at a pressure and volume specified by NIOSH. Use NIOSH approved air filters on all sources of breathing air. See Section 3.10.

DANGER

Breathing air filters do not remove carbon monoxide or any other toxic gases. Use a carbon monoxide monitor to detect unacceptable levels. Consult OSHA 29 CFR 1910.134(i).

Many sources of breathing air are available such as air cylinders, free-air pumps, oil-less air compressors, and oil lubricated air compressors. The most commonly used is the same air compressor that is used for the blast air which most often is oil lubricated. Breathing air provided by an oil-lubricated air compressor can contain carbon monoxide and therefore requires the use of a carbon monoxide detector (See Section 3.10). Carbon monoxide can be in the compressed air produced by an oil-lubricated air compressor when it is operated at extremely high temperature; therefore, a high temperature alarm is required to alert the operators when this condition exists.

DANGER

Oil lubricated air compressors can produce carbon monoxide. Carbon monoxide can cause asphyxiation and result in death. Use a high-temperature alarm and a carbon monoxide monitor when an oil lubricated air compressor is used to supply breathing air. Consult OSHA 29 CFR 1910.134(i).

3.10 Personal Protective Equipment (PPE)

Abrasive blasting has many hazards that may cause injuries to operators. To protect operators from injury each must be supplied with, and required to use Personal Protective Equipment. The Occupational Health and Safety Administration (OSHA) requires the employer to assess the workplace to determine what PPE is necessary and supplied to each operator (Reference 29 CFR 1910 Subpart I). OSHA requires that this equipment meet or be equivalent to standards developed by the American National Standards Institute (ANSI). Figure 3.10 below identifies the minimum personal protective equipment required for each abrasive blast operator. Also identified are the OSHA references for each and the ANSI standard each PPE item must meet. All PPE clothing and equipment should be selected for safe design and quality of construction. Select each for proper fit and for comfort which will encourage operator use.



Safety Glasses

Reference OSHA 29 CFR 1910.133
Must meet ANSI Z87.1 - 1989



Safety Boots

Reference OSHA 29 CFR 1910.136
Must meet ANSI Z41.1 - 1991



Ear Plugs

Reference OSHA 29 CFR 1926.101
Must meet ANSI S3.19
(Also see OSHA 29 CFR 1910.95)

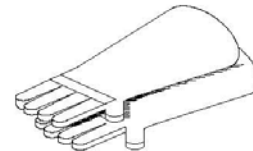

Gloves

Reference OSHA 29 CFR 1910.138
No Applicable ANSI Standard

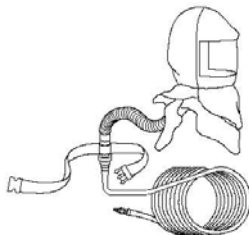

Respirator

Reference OSHA 29 CFR 1910.134
Must be NIOSH approved



Protective Clothing

Reference OSHA 29 CFR 1910.138
No Applicable ANSI Standard



Airline Filter

Reference OSHA 29 CFR 1910.134
Must be NIOSH approved

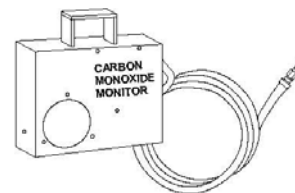

Carbon Monoxide Monitor

Figure 3.10 - Personal Protective Equipment

3.11 Pressure Relief Valve Installation

Do Not operate this equipment without a pressure relief device installed to protect the blaster pressure vessel from over-pressurization. The ASME Code requires that all vessels be operated with pressure relief devices in place.

If the compressed air system does not provide for the installation of a pressure relief valve one can be installed on the blowdown port on the pressure vessel. Refer to Figure 3.11 for an alternate location of the air pressure relief valve.

Local regulations set the specifications for pressure relief valves; therefore, it is the responsibility of the owner of the abrasive blaster to install a pressure relief valve that meets *all* applicable regulations. The pressure relief device must be set at the maximum allowable working pressure of the abrasive blaster pressure vessel See the ASME/CE vessel nameplates attached to the pressure vessel.



Rupture Hazard. Operating the pressure vessel above the maximum allowable working pressure can result in rupturing the pressure vessel. Install an air pressure relief valve to protect against over pressurization of the blast vessel.



Airborne particles and loud noise hazards from relief valve exhaust air can cause serious injury and loss of hearing. Wear approved eye and ear protection. Stay clear of exhaust air path. DO NOT place hands or other body parts in the exhaust air path. Make sure no personnel are in the exhaust air path. Direct the relief valve exhaust away from work area.

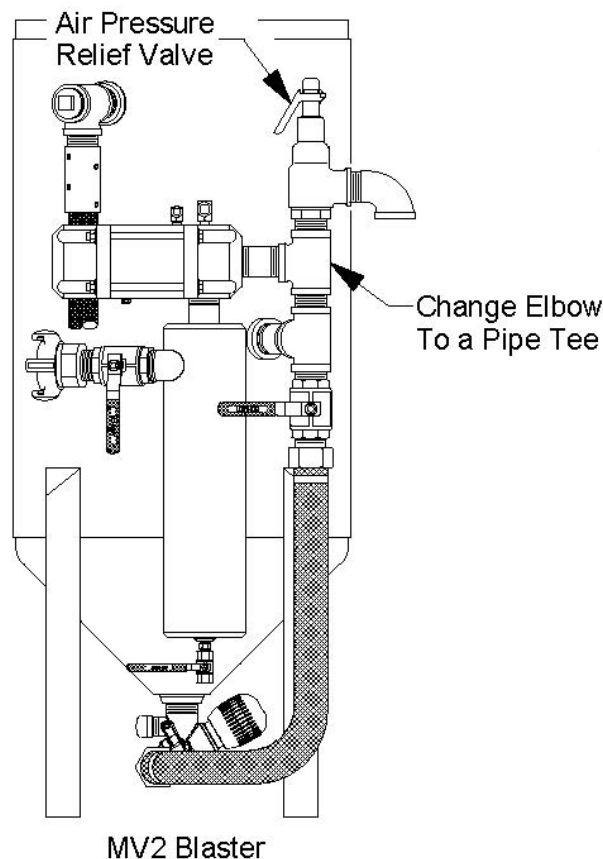

Figure 3.11 – Suggested location for air pressure relief valve

3.12 INSTALLATION CHECKLIST (Photocopy this page to use as a worksheet)

- Deadman/Twinline (or cords):** confirm delivery with the abrasive blaster.
- Blast accessories:** confirm receipt as purchased with the blaster.
- Inspect blaster:** check for possible damage during shipment. See Section 8.0 for inspection instructions.
- Popup alignment:** remove popup dust cover from top head and check popup alignment. Shifting of popup is possible during shipment. See Section 8.4 for inspection & alignment instructions.
- Clean blaster:** remove handway cover and check for debris inside. Trapped debris can vibrate loose during shipment and later block abrasive flow. If necessary vacuum the bottom of tank. Replace handway cover per instructions in Section 6.3.
- Accessible location:** install stationary blasters so that handway is accessible for maintenance. See Section 3.1 for additional information.
- CFM available:** determine available air supply (cfm) and record here. _____
See Sections 3.2, 3.3, and 3.5 for information on determining air requirements.
- Air supply connection:** install air supply piping or connect an air supply hose that is the same size as the blaster piping size or larger. See Section 3.4 for details.
- Air quality:** install moisture separator or AirPrep System to remove moisture from blast air supply to protect against abrasive flow problems. See Section 3.6.
- Electric power:** provide power source for electric deadman controls. See Section 3.7.
- Blast abrasive:** select abrasive suited for application. See Section 3.8.
- Breathing air:** provide Grade D air source for blast operators. See Section 3.9.
- PPE:** provide all the necessary personal protective equipment. See Section 3.10.
- Pressure relief valve:** install relief valve if not provided on air compressor. See Section 3.11 for information on pressure relief valve installation.
- Blast nozzle:** select size based on available cfm noted above. See Section 5.11.
- Blast hose:** select size three times the nozzle size to be used. See Section 5.10.
- Operator training:** all operators must completely read and understand the operation and maintenance manual and be properly trained in equipment and blast operations.
- Abrasive Blaster Setup:** follow procedures in Section 6.0.

4.0 Abrasive Blast System General Operation

The function of the Schmidt® abrasive blaster is to provide a mixture of dry abrasive and compressed air to a blast nozzle. The abrasive blast stream through the blast nozzle is used for removing rust, paint, or other unwanted surface defects. After abrasive blasting, the surface is ready for new paint or coating.

An abrasive blaster is one of a group of components used in an abrasive blasting job. The typical components are an air compressor, moisture removal device, an abrasive blaster, blast hose, a blast nozzle, operator personal protective equipment, and blast abrasive. See Figure 4.1.

The blast abrasive is loaded into the abrasive blaster through the abrasive inlet at the top of the blaster. All the compressed air must be removed from inside the abrasive blaster before it can be filled with abrasive. The abrasive can be bag loaded, or loaded from a Schmidt storage hopper. To begin blasting, the abrasive inlet is closed and the abrasive blaster is filled with compressed air from the air compressor. Since moisture creates problems in the blast operation, it is common for the compressed air to be fed through a moisture removal device, such as a Schmidt AirPrep System. The air pressure in the abrasive blast vessel is equal to the air pressure in the blast hose where it connects at the metering valve. This equal pressure is needed to allow the blast abrasive to flow downward by gravity. The abrasive flow is controlled by the metering valve at the bottom of the blaster. From the metering valve the blast abrasive flows into the blast air stream and through the blast hose. The speed of blast air and abrasive mixture is greatly increased by the blast nozzle onto the work surface. The high speed of the air and abrasive is what gives it the energy to blast rust and paint off of surfaces. The abrasive blast stream and the dust it creates are harmful; therefore, all blast operators must use personal protective equipment during the blast operation.

All the components required for the blast operation (except for the air compressor) are available from Axxiom Manufacturing, Inc. Call Axxiom to locate a distributor.

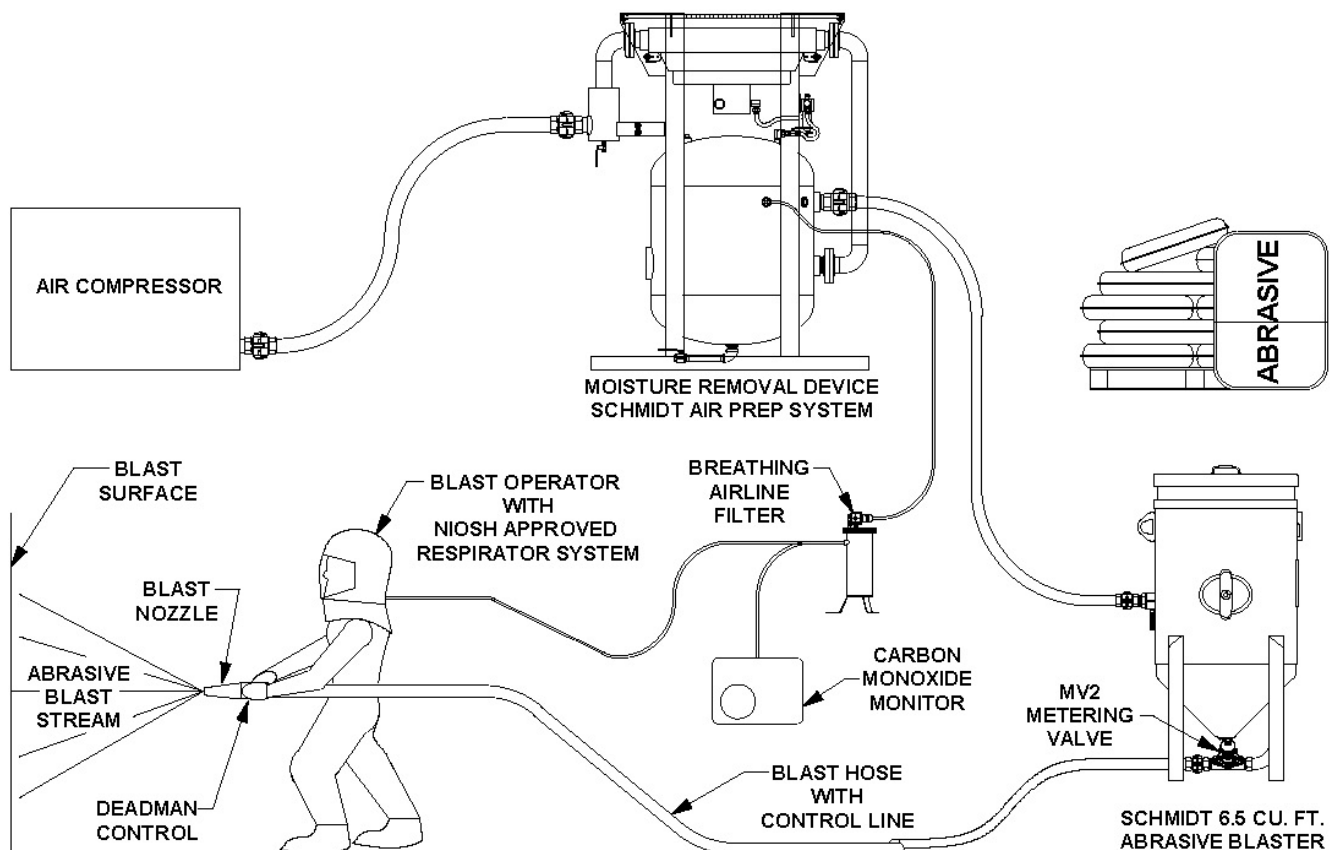

Figure 4.1 – Typical Abrasive Blast System

5.0 MV2 Abrasive Blaster General Operation

See Figure 5.1 below or Figure 9.2(a) (page 50) to help understand the general operation of a MV2 abrasive blaster. Do not attempt to operate the abrasive blaster before reading all sections of this manual and following all setup procedures. Read Sections 5.1 through 5.16 for a detailed explanation of all components of the MV2 abrasive blaster.

The MV2 abrasive blaster is a *depressurized system*; meaning the blaster will pressurize only when the Combo Valve® is opened by pressing the deadman lever (#12).

Compressed air enters the blast system when the air inlet ball valve (#3) is opened. Air flows through the moisture separator (#7) and into the supply side of Combo Valve (#4). Air is supplied to the deadman valve (#12) from the Combo Valve. When the deadman lever (#12) is pressed down signal air will flow back to open the Combo Valve. When the Combo Valve opens air will flow into the blast vessel internal piping. The air flow pushes the popup (#5) against the gasket (#6) to seal the abrasive inlet and allow the air flow to pressurize the blast vessel (#1) and the blaster piping (#13).

Blasting starts when the deadman lever (#12) is pressed down. Compressed air will flow from the Combo Valve (#4) to the blast hose (#10). The choke ball valve (#13) must be open during the blast operation. Abrasive will flow through the MV2 Valve (#14) and fall into the blast air stream. The abrasive flow can be increased or decreased by turning the knob on top of the MV2 Valve (#14). Because of the length of the blast hose it will take a few seconds to see changes in abrasive flow.

Blasting stops when the deadman lever (#12) is released. This will close the Combo Valve (#4) and depressurize the vessel at the same time. The compressed air in the abrasive blaster will exhaust through the blowdown hose (#9). The MV2 abrasive blaster (#1) remains depressurized when the Combo Valve (#4) is closed.

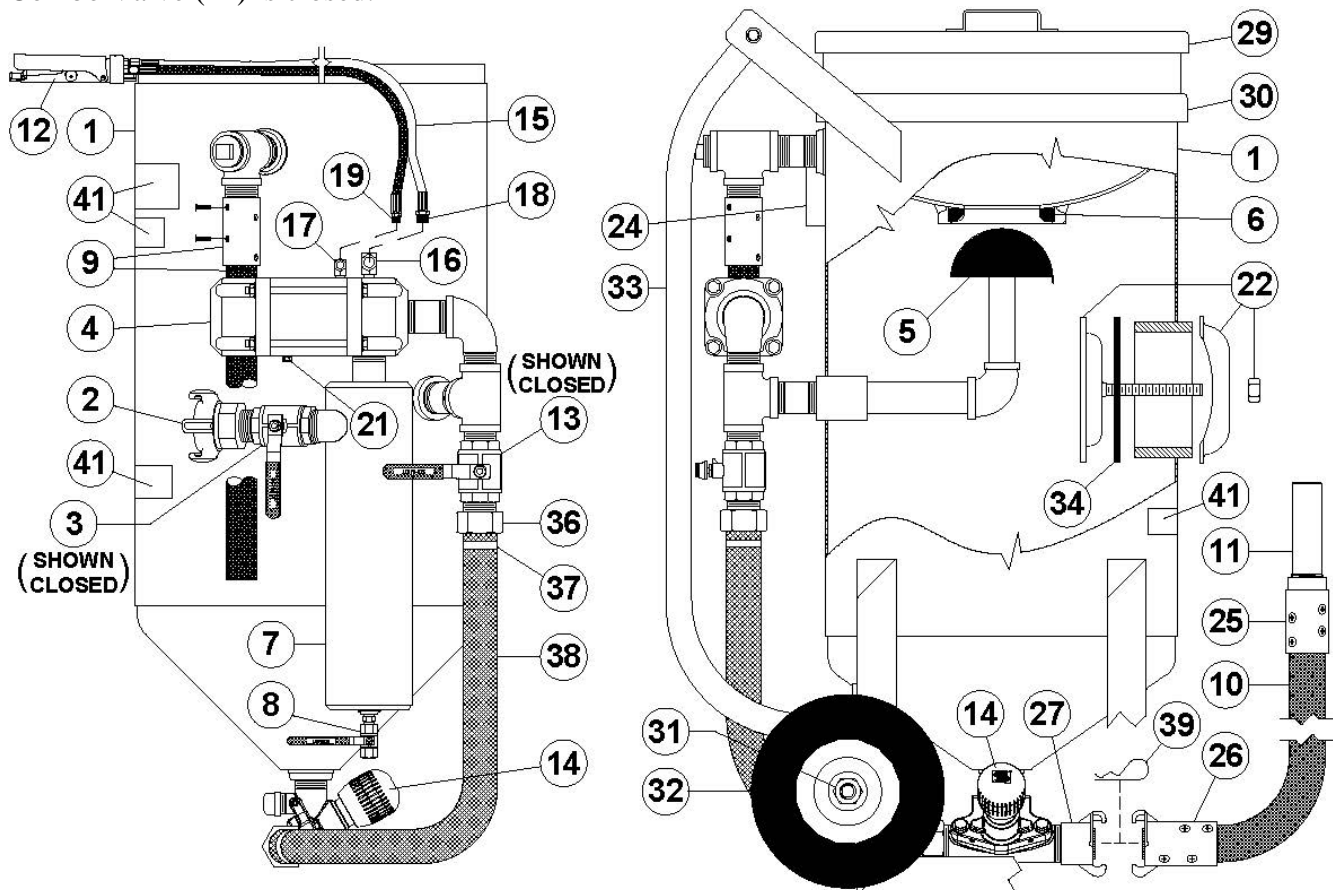

Figure 5.1 – MV2 Abrasive Blaster with pneumatic blast controls

5.1 Popup Valve (abrasive inlet)

The blaster is filled with abrasive through the abrasive inlet at the top of the pressure vessel. The abrasive inlet is automatically sealed by the popup head (#5) when the blaster is pressurized. The air flow into the internal piping pushes the popup up (#5) against the gasket (#6). See Figure 5.2.

⚠ WARNING

Pinch point hazard. Vessel pressurization will close the popup. Keep hands and fingers away from popup. Disconnect air supply prior to performing popup maintenance.

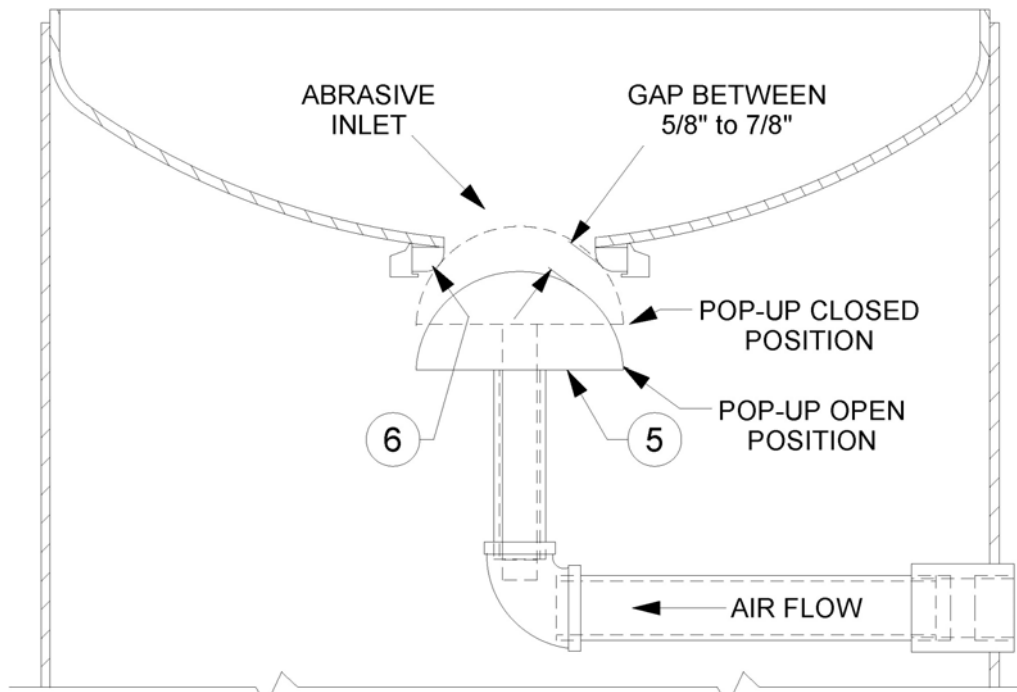

Figure 5.2 – Standard Popup Assembly & Internal Piping

5.2 Air Supply Connection

Air is supplied to the abrasive blaster through a hose connection at the air inlet crowfoot (#2). The air supply hose connected to the abrasive blaster must be same diameter as the air supply piping and rated at a minimum of 150psi operating pressure. See the drawings and parts lists in Section 9.0 and refer to Sections 3.4 and 5.12.

5.3 Air Inlet Ball Valve

The air inlet ball valve (#3) is used to turn on and turn off the air flow to the abrasive blaster. When the inlet ball valve is opened, air will flow through the moisture separator (#7) and into the Combo Valve® (#4). In a properly operating MV2 Valve / Combo Valve system the blast vessel *does not* pressurize when the inlet ball valve is opened.

5.4 Moisture Separator (optional)

The air inlet moisture separator is an option available on the abrasive blaster. Air flow into the blaster passes through the moisture separator (#7) which removes moisture, oil and dirt particles from the inlet air. The water that is removed by the separator is drained by opening the ball valve (#8) at the bottom of the separator. This ball valve should be left slightly opened anytime the blaster is in operation. This allows water to be drained as it is filtered from the blast air. **Note:** Not all abrasive blasters are equipped with a moisture separator.

5.5 Combo Valve® (blast vessel pressurization/blowdown)

The Combo Valve (#4) is a dual purpose valve that controls both the blast vessel pressurization and the blast operations. At one end the valve pinches the 3/4" blowdown hose (#9) to seal it and allow air to pressurize the blast vessel. At the other end the Combo Valve opens and allows air to flow to the blast vessel (#1) and through the blast air piping to the blast nozzle. See the Combo Valve drawing in Section 9.6.

The Combo Valve opens and blasting starts when the deadman lever (#12) is pressed down. The blast vessel will pressurize.

The Combo Valve closes and blasting stops when the deadman lever (#12) is released. The blast vessel will depressurize (blowdown).

When the Combo Valve closes the pinch ram on the blowdown hose (#9) is released and the air inside the blast vessel (#1) will exhaust through the blowdown hose. The MV2 Valve abrasive blaster (#1) remains depressurized when the Combo Valve (#4) is closed. The abrasive blaster must be depressurized before filling with abrasive or before performing any maintenance.



The MV2 Valve abrasive blaster is a pressurized vessel. Propelled objects will cause serious injury or death. Read and follow all pre-operation and operating procedures prior to pressurizing the abrasive blaster. See Sections 6.0 and 7.0.



Airborne particles and loud noise hazards from blowdown exhaust air can cause serious injury and loss of hearing. Wear approved eye and ear protection. Stay clear of blowdown air path. DO NOT place hands or other body parts in the blowdown air path. Make sure no personnel are in the blowdown air path.

5.6 Choke Valve

The choke valve (#13) is used to clear any trash that may get into the blast vessel and block the MV2 Valve (#14) orifice. Whenever trash (paint chips, cigarette butts, etc.) blocks the MV2 Valve orifice the procedure is to fully open the MV2 Valve by backing out the knob, then press down the deadman lever (#12) to begin blasting. While blasting, have an assistant close the choke valve completely for about one second. This creates differential pressure at the MV2 Valve (high pressure above; low pressure below). The higher pressure from the blast vessel should be enough to force the trash through the MV2 Valve orifice. Keep the choke valve fully open at all other times while blasting to minimize excess MV2 Valve wear.



Do not aim blast nozzle towards yourself or any person. System malfunction can cause accidental start up and result in injury to personnel.

A secondary purpose of the choke valve is as a manual shut off valve for the blast air supply. When the choke valve (#13) is closed it will shut off the blast air supply to the blast outlet.

5.7 MV2 Valve (abrasive metering valve)

The MV2 Valve (#14) is used to control (meter) abrasive flow by use of an adjustable orifice. The size of this orifice is controlled by turning the knob at the top of the MV2 Valve. Turning the knob clockwise reduces the orifice size which decreases abrasive flow. Turning the knob counter-clockwise increases the orifice size which will increase the abrasive flow to the blast nozzle (#11). Adjustments to the abrasive flow should be made by turning the knob a little at a time. Test the adjustment by starting the blast for a short period to determine if further adjustment is needed. The MV2 Valve has an orifice indicator on the body to use as reference as to the amount the orifice is open. **Note:** For proper operation the abrasive flow must be in the direction of the arrow on the base (see Section 9.5)

The MV2 Valve has a cleanout port where a ball valve can be installed and used to purge trash that blocks abrasive flow. This is done by opening the clean out valve and pressing down the deadman lever (#12). The blast air flow purges trash through the clean out valve.

▲ WARNING

Airborne particles and loud noise hazards from purged air can cause serious injury and loss of hearing. Wear approved eye and ear protection. Stay clear of purge air path. **DO NOT** place hands or other body parts in the purge air path. Make sure no personnel are in the purge air path.

5.8 Deadman Valve/Switch (blast control)

The Deadman valve/switch is part of the system that controls the blast operation. The deadman allows the operator to remotely start and stop the blast operation. The deadman is mounted at the end of the blast hose assembly (#10) near the blast nozzle (#11) to give the operator easy control of the blast operation.

The Deadman is either a pneumatic valve or an electric switch depending on the type of abrasive blaster control system. When the deadman lever is pressed down it sends either a pneumatic or electric signal to the Combo Valve. The Combo Valve opens and starts the blast operation. See Sections 9.1, 9.2, 9.3, 9.8, and 9.9.

5.8.1. Pneumatic Deadman System: When the pneumatic deadman (#12) lever is pressed down, air supply from the orange hose of the twinline hose (#15) flows into the black hose. Air flows through the black hose to the signal port of the Combo Valve (#4) to open it and send air into the abrasive blaster and blast air hose. When the deadman lever is released the air signal is cut off and the Combo Valve is closed to shut off the supply air and depressurize the blaster through the blowdown hose assembly (#9). See Figure 5.3 and the drawings in Sections 9.1 and 9.2.

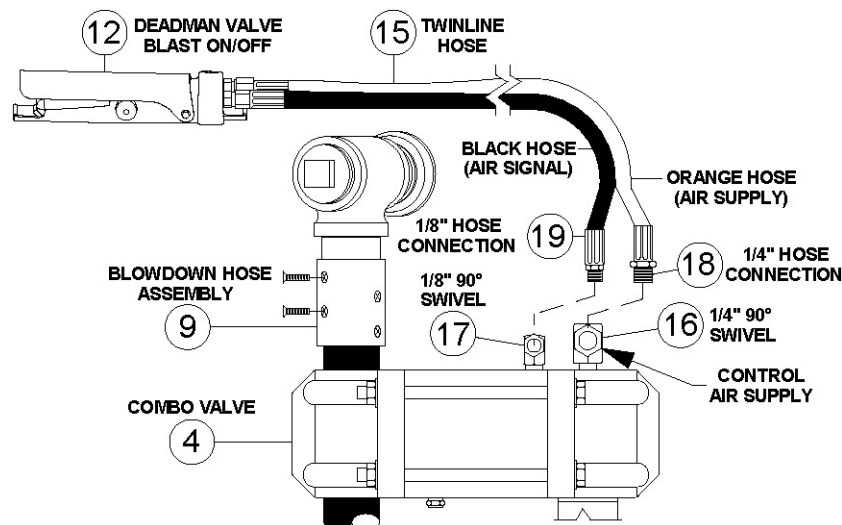

Figure 5.3 – MV2/Combo Pneumatic Deadman Blast Control System

5.8.2. **Electric Deadman System:** When the electric deadman lever (#12) is pressed down it closes the electric circuit and supplies electric current to the control valve (#20). The control valve opens and sends air signals to the Combo Valve (#4) to begin blasting. When the deadman lever is released the electric circuit is turned off closing the control valve. The signal air vents from the breather (#35) and the Combo Valve closes to stop blasting. See Figure 5.4, Figure 5.5 and the drawing in Section 9.3.



Electric shock hazard. Abrasive blasters with electric deadman blast control systems must operate on low voltage supply (12-24 volts). To minimize shock hazard only use low voltage sources and use caution when connecting the power to the abrasive blaster. See Section 3.7.

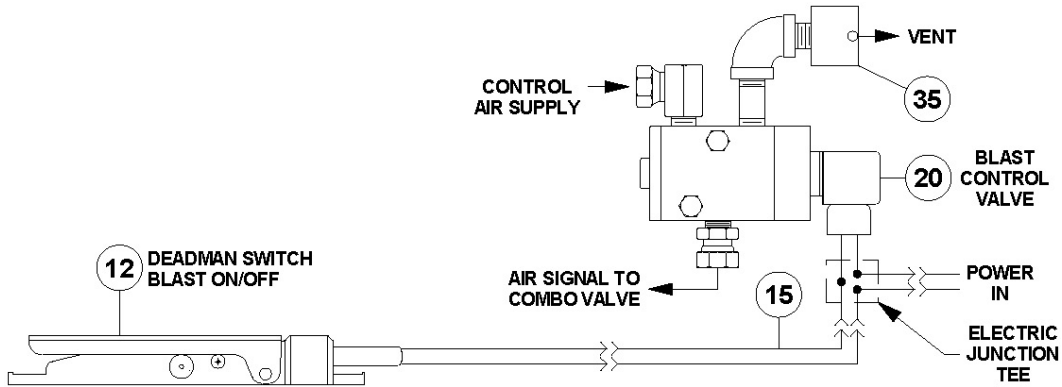

Figure 5.4 – MV2 Valve Electric Deadman Blast Control System

5.9 MV2 Valve Abrasive Blaster with Electric Control System

Figure 5.5 shows a MV2 Valve abrasive blaster with the electric deadman system. The popup valve, MV2 Valve, and Combo Valve operate the same as a blaster with a pneumatic blast control system. The difference is that the electric control system uses an electric control valve (#20) operated by the electric deadman switch as detailed in Section 5.8.2.

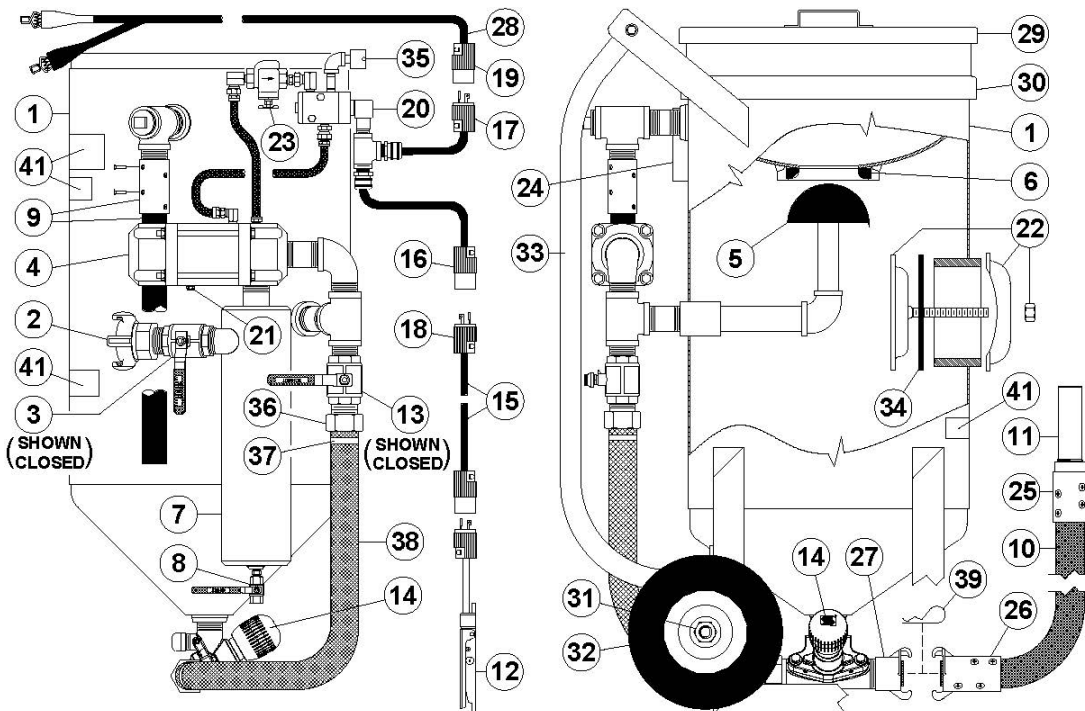

Figure 5.5 – MV2 Valve Abrasive Blaster with electric blast controls

5.10 Blast Hose

The blast air and abrasive mixture flows from the MV2 Valve (#14) to the blast nozzle (#11) through the blast hose assembly (#10). The typical length of the blast hose is 50ft; however blast hose extensions can be added to increase length. For higher efficiency keep the blast hose as short as possible. Increased blast hose length causes pressure drop at the blast nozzle which reduces the blast efficiency. For higher efficiency use a blast hose with an inside diameter that is approximately three times the nozzle throat diameter. Keep blast hose as straight as possible. Sharp bends create high wear points. Static electricity is generated by the abrasive flow through the blast hose. To minimize the chance of static electrical shock to operating personnel only use static dissipating blast hose and install a grounding strap on the abrasive blaster.



Static electric shock hazard. To minimize the chance of static electric shock install a grounding strap on the abrasive blaster and only use static dissipating blast hose.

Note: To reduce operator fatigue a blast whip hose can be used along with the blast hose. A whip hose is thinner wall and lighter weight hose. Consult an Authorized Schmidt® distributor.

5.11 Blast Nozzle

The blast nozzle (#11) is an important part of the blast operation since the size of it determines the air flow and abrasive requirement. The amount of air flow and abrasive determine how quick blasting can be done. The larger the nozzle, the more air and abrasive will be needed. The larger the nozzle size the greater the blast productivity. However, for a fixed amount of air supply, increasing the nozzle size will reduce the blast pressure. For best performance the blast pressure must be maintained as high as possible. Therefore, select the nozzle size based on the amount of air available and then adjust the abrasive flow at the MV2 Valve as needed.

The nozzle size is indicated by a small number on the outside of the nozzle. This number represents the nozzle throat diameter in sixteenths of an inch; for example, a #5 nozzle has a throat diameter of 5/16". See the tables in Section 13.0 for approximate air and abrasive consumption for each nozzle. **Note:** For the best possible mixture of air to abrasive, the blast hose and piping must be at least three times the size of the blast nozzle.

5.12 Hose Connection

All air hose, blast hose, and threaded couplings have pin holes that align when connected. To protect against accidental hose disconnections safety pins must be installed through these holes. As a secondary safety measure each hose connection should also include a hose whip check that will hold the hose if there is an accidental disconnection. Connect one loop to each side of the connection and stretch out as shown in Figure 5.6 below. All air hose, blast hose, and threaded couplings have a gasket that seals the connection and should be replaced when air is leaking.



Failure to install safety pins on all air and blast hose couplings can result in hose disconnects and could result in serious injury or death.

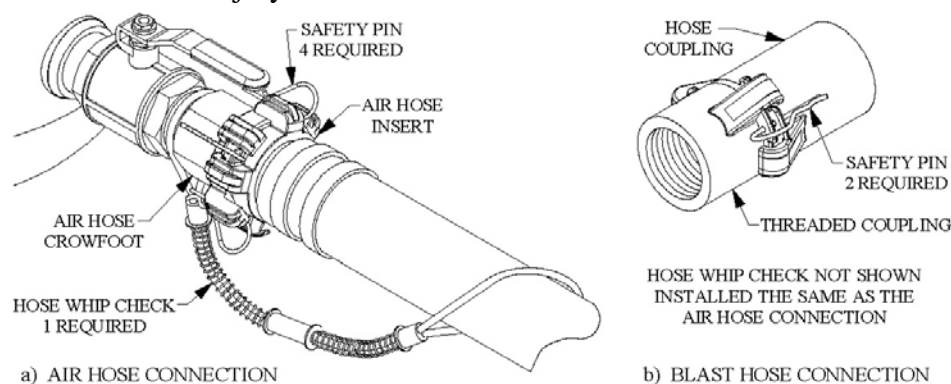

Figure 5.6 – Hose Connection Disconnect Protection

5.13 Union End Ball Valve (optional)

The union ball valve is used to block the abrasive flow to the MV2 Valve. This allows the user to remove the MV2 Valve from the blast vessel without emptying the abrasive. Turn the union ball valve handle to the horizontal position to block abrasive flow. Loosen the nut to separate the two sections of the union ball valve and remove the MV2 Valve from blast vessel. The handle on the union ball valve can be difficult to turn; however, there are punched holes at each arm of the handle where a standard ratchet wrench can be inserted and used as leverage to open or close the valve. **Note:** Units manufactured after February 2015 are equipped with the ergonomic round handle design (see Figure 5.7).

⚠ DANGER

The Abrasive blaster is a Pressurized Vessel. Propelled objects will cause serious injury or death. Depressurize vessel before performing any maintenance. See Section 6.2.

Note: The union end ball valve is optional and can be added to any blaster; however, some models may require extensions below the legs for field addition. Consult Axxiom Manufacturing or an Authorized Schmidt® distributor.

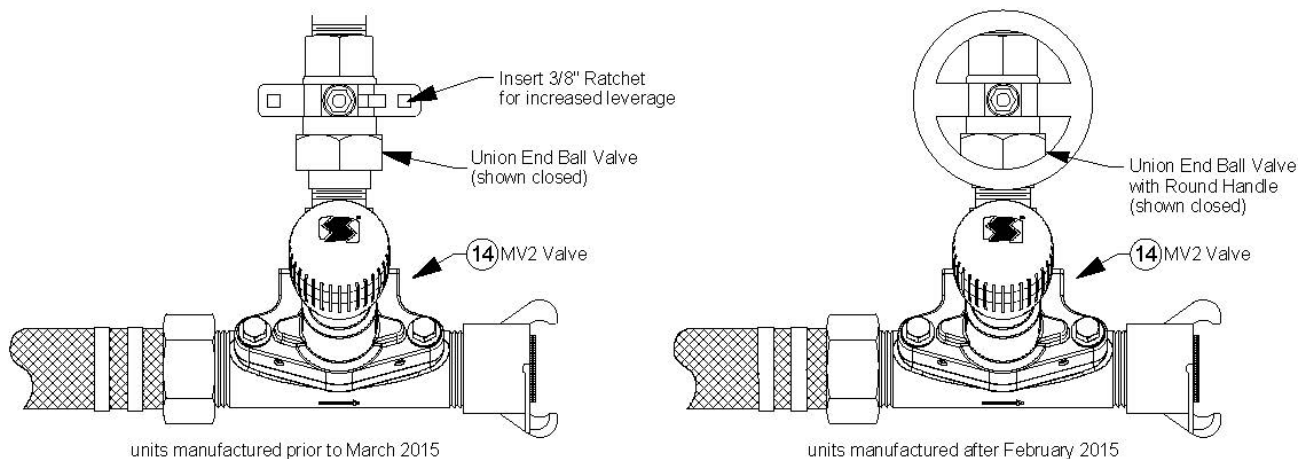

Figure 5.7 – Union End Ball Valve

5.14 Thompson Valve Conversion

The MV2 Valve abrasive blaster is best suited for large blast projects where the operator will blast for long periods without repeated starts and stops. Because the M2 blaster is a *depressurized* blast system all the air pressure in the blast vessel is vented each time the deadman lever is released. When blasting is restarted differential pressure occurs at the MV2 valve until the blast vessel reaches full pressure. This differential pressure causes momentary wear in the MV2 and does so each time the blaster is restarted. Therefore, for blast applications that are short blast times and frequent start and stops it is recommended to use a Thompson Valve® blast system to minimize wear caused by differential pressure. Conversion kits are available to convert MV2 blasters to Thompson valve controls. Consult Axxiom Manufacturing or an Authorized Schmidt® distributor.

5.15 Dual Outlet Blast System (10cf and 20cf)

The 10cf and 20cf blast vessels are fabricated with two additional abrasive outlet couplings. These vessels can be purchased as dual outlet or field converted to dual outlet blasters. Consult Axxiom Manufacturing or an Authorized Schmidt® distributor.

5.16 Options and Accessories

There are many options, accessories, and field conversion kits available to upgrade Schmidt® abrasive blasters. Options include media screen & lid, media spider, angle flange, door interlock, air pressure regulator, blast hour meter, “Short Stop” blast system, ASAP Safety System, and others. Consult Axxiom Manufacturing or an Authorized Schmidt® distributor.

For blasters equipped with special options refer to the supplemental drawing(s) included with this manual. Reference this drawing for additional part identification.

6.0 Pre-operation Procedures

DANGER

Failure to follow the procedures below could result in serious injury or death. In addition to these procedures completely read and understand all sections of this *Abrasive Blaster Operation and Maintenance Manual*.

DANGER

The Abrasive Blaster is a pressurized vessel. Propelled objects will cause serious injury or death. Depressurize vessel before performing any maintenance. See Section 6.2.

6.1 Abrasive Blaster Setup Procedure (see Figure 6.2)

6.1.1. Confirm that the abrasive blaster is properly maintained and inspected as detailed in Section 8.0.

6.1.2. Static electricity is generated by the abrasive flow through the blast hose. To minimize the chance of static electric shock to operating personnel only use static dissipating blast hose and install a grounding strap on the abrasive blaster.

CAUTION

Static electric shock hazard. To minimize the chance of static electric shock install a grounding strap on the abrasive blaster and only use static dissipating blast hose.

6.1.3. Do Not operate this equipment without a pressure relief device in place. The ASME Code requires that all vessels be provided with pressure relief devices. See Section 3.11.

DANGER

Rupture Hazard. Operating the pressure vessel above the maximum allowable working pressure can result in rupturing the pressure vessel. Install an air pressure relief valve to protect against over pressurization of the blast vessel. See Section 3.11.

6.1.4. Make certain that the abrasive blaster is not pressurized. Follow the depressurizing procedure given in Section 6.2.

WARNING

Airborne particles and loud noise hazards from blowdown exhaust air can cause serious injury and loss of hearing. Wear approved eye and ear protection. Stay clear of blowdown air path. DO NOT place hands or other body parts in the blowdown air path. Make sure no personnel are in the blowdown air path.

6.1.5. Properly install the handway cover (#22) and gasket (#34). See Section 6.3.

6.1.6. Verify that all required personal protective equipment is available for each operator and in good operating condition (safety glasses, safety shoes, ear plugs, gloves, airline filter, respirator, & carbon monoxide monitor). *Critical: Adhere to all local, state, and federal regulations including, but not limited to, OSHA (Occupational Health and Safety Administration). Pay close attention to requirements regarding breathing air quality. When an oil-lubricated air compressor is used, additional requirements for a high temperature alarm and/or a carbon monoxide monitor become necessary. See Sections 3.9 and 3.10.*

WARNING

Failure to use personal protective equipment could result in serious injury or death.

- 6.1.7. Hose clamp the deadman (#12) to the blast hose assembly in a comfortable position behind the nozzle holder (#25).
- 6.1.8. Wire tie the twinline hose (#15) or electric deadman extension cords to the blast hose assembly (#10).
- 6.1.9. Screw nozzle (#11) into the nozzle holder (#25) at end of the blast hose assembly (#10).
- 6.1.10. Connect the blast hose coupling (#26) to the threaded coupling (#27) on the abrasive metering valve (#14). Then install safety pins (#39) and a hose whip check (#40) to protect against accidental disconnections during operation. See Sections 5.12, and 8.7.

⚠ WARNING

Failure to install safety pins on all blast hose couplings can result in hose disconnects and could result in serious injury or death. See Sections 5.12 and 8.7.

- 6.1.11. Connect the twinline hose quick disconnects (#18 & #19) or the electric deadman extension cord to the mating disconnect(s) (#16 & #17) on the abrasive blaster piping.
- 6.1.12. Connect a 150 psi rated (minimum) air supply hose to the air inlet crowfoot (#2) and install safety pins (#39) and a hose whip check (#40) to protect against accidental disconnections during operation. See Sections 5.12 and 8.7.

⚠ WARNING

Failure to install safety pins on all air hose couplings can result in hose disconnects and could result in serious injury or death. See Sections 5.12 and 8.7.

- 6.1.13. The following steps apply only to abrasive blasters with electric systems. Connect the electric power cord (#28) to the blaster junction tee connector (#17).
- 6.1.14. Connect the electric power cord alligator clips (#28) to the air compressor battery terminals or to another 12Vdc power source. See Figure 6.1.

⚠ CAUTION

Electric shock hazard. Abrasive blasters with electric deadman blast control systems must operate on low voltage supply (12-24 volts). To minimize shock hazard only use low voltage sources and use caution when connecting the power to the abrasive blaster. See Section 3.7.

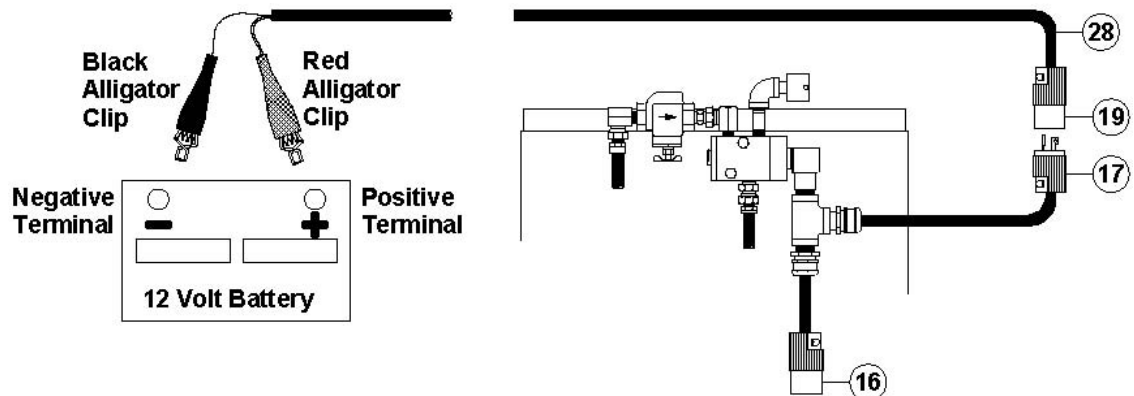

Figure 6.1 – Electric power connection

6.2 Abrasive Blaster Depressurizing Procedure

A MV2 Valve blaster is a *depressurized system*; meaning that the blaster will depressurize when the deadman (#12) is released.

- 6.2.1. Release the deadman (#12) to deactivate the Combo Valve® (#4) and depressurize the abrasive blaster. The blast operation will stop.

⚠ WARNING

Airborne particles and loud noise hazards from blowdown exhaust air can cause serious injury and loss of hearing. Wear approved eye and ear protection. Stay clear of blowdown air path. **DO NOT** place hands or other body parts in the blowdown air path. Make sure no personnel are in the blowdown air path.

- 6.2.2. The popup head (#5) will fall open when the blast vessel is completely depressurized.

⚠ WARNING

When the popup valve opens after depressurizing, abrasive can be blown out of the blast vessel and into the face and eyes of the operator. Wear OSHA approved safety glasses. See Section 3.10.

- 6.2.3. Close the air inlet ball valve (#3) to disable the blaster and the deadman blast control. The ball valve is closed when the handle is fully turned to the position shown in Figure 6.2 (handle perpendicular to body). The handle tab will bottom against the ball valve body in the closed position.

- 6.2.4. The blowdown hose (#9) and fittings should be periodically inspected for wear. Refer to Section 8.0 for inspection and maintenance details.

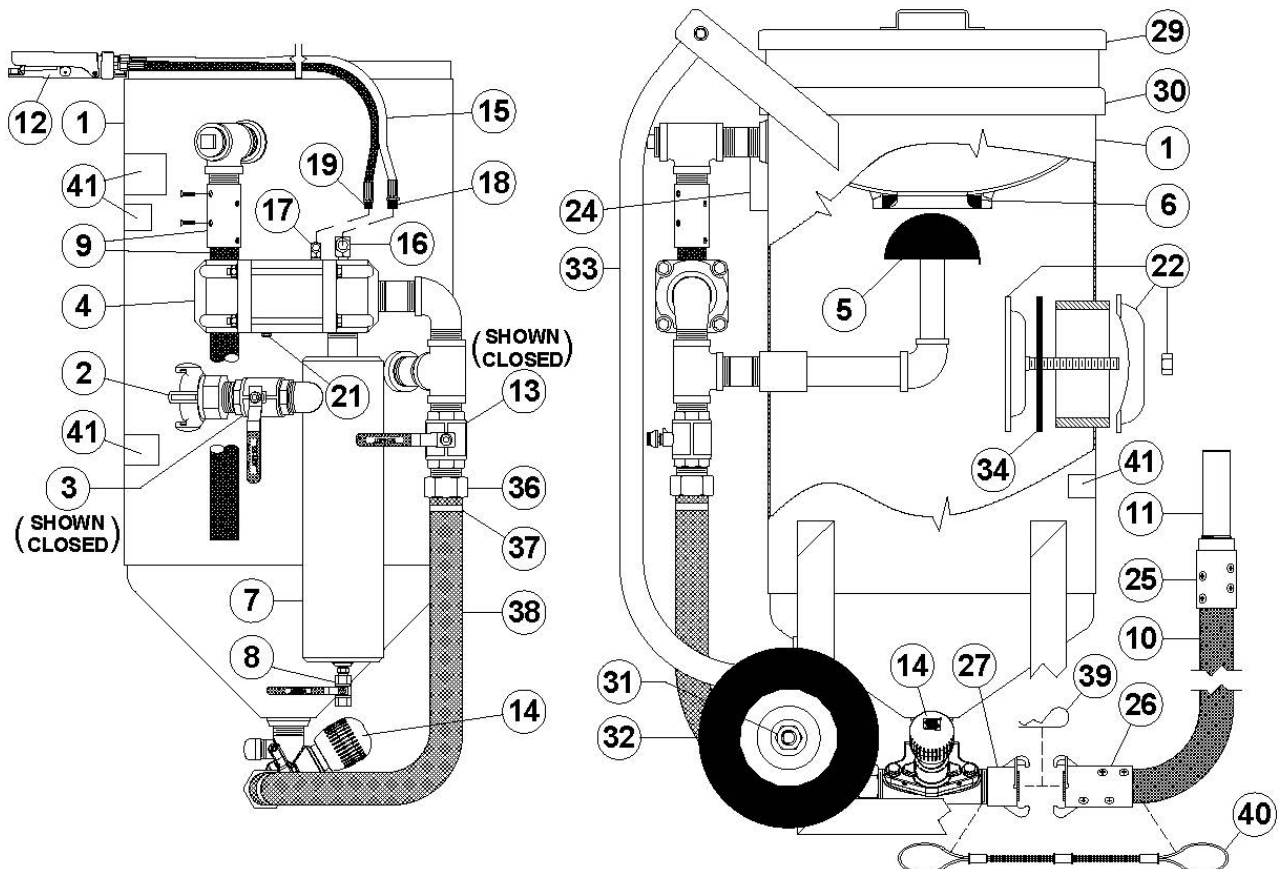

Figure 6.2 – MV2 Valve Abrasive Blaster with pneumatic blast controls

6.3 Handway Cover Installation Procedures (See Figure 6.3(a))

- 6.3.1. Check that the handway cover, crab, bolt, and gasket are dimensionally correct for the size handway weld ring of the pressure vessel.
 - a) Measure and write down the inside dimensions “A” and “B” of the handway weld ring. See Figure 6.3(a).
 - b) Verify the size of the handway assembly by comparing the weld ring measurements from step “a” to the dimensions shown in Table 6.3(c).
 - c) Verify that the dimensions of the cover, crabs, bolts, and gasket match the corresponding dimensions given in Table 6.3(c). **Note:** The actual dimensions may vary by up to 1/4" from those given in Table 6.3(c).
 - d) Replace any component that is not dimensionally correct. Incorrect dimensions indicate that the component is part of a different size handway assembly.



The handway assembly is part of a Pressurized Vessel. Use of incorrect handway components will result in assembly failure. Assembly failure will propel objects causing serious injury or death.

- 6.3.2. Once a month inspect the handway gasket for tears, cracks, or other wear. Replace if necessary.
- 6.3.3. Once a month inspect the handway weld ring sealing surface inside the vessel. Inspect the handway cover sealing surface. Both surfaces must be smooth.
- 6.3.4. Place the gasket on the handway cover then fit both through the opening.
- 6.3.5. Place the cover and gasket in position against the inside edge of the handway weld ring. Apply a pulling force to hold in position then proceed.
- 6.3.6. Center the gasket on the handway weld ring.
- 6.3.7. Center the handway cover on the gasket.
- 6.3.8. Center the handway crab on the outside weld ring.
- 6.3.9. Slide the handway crab bolt to the inside edge of the slot before tightening. See Figure 6.3(a).
- 6.3.10. When all components are centered and the crab bolt is bottomed in the slot, tighten the nut onto the bolt with a wrench until snug.
- 6.3.11. Only after completing all the pre-operation procedures in Section 6.0 and the abrasive blast vessel is then pressurized, re-tighten the nut with a wrench until snug again.
- 6.3.12. Do not over-tighten the crab nut and bolt. Over-tightening could bend the crab out of shape resulting in malfunction of the assembly.
- 6.3.13. Periodically check for leaks.

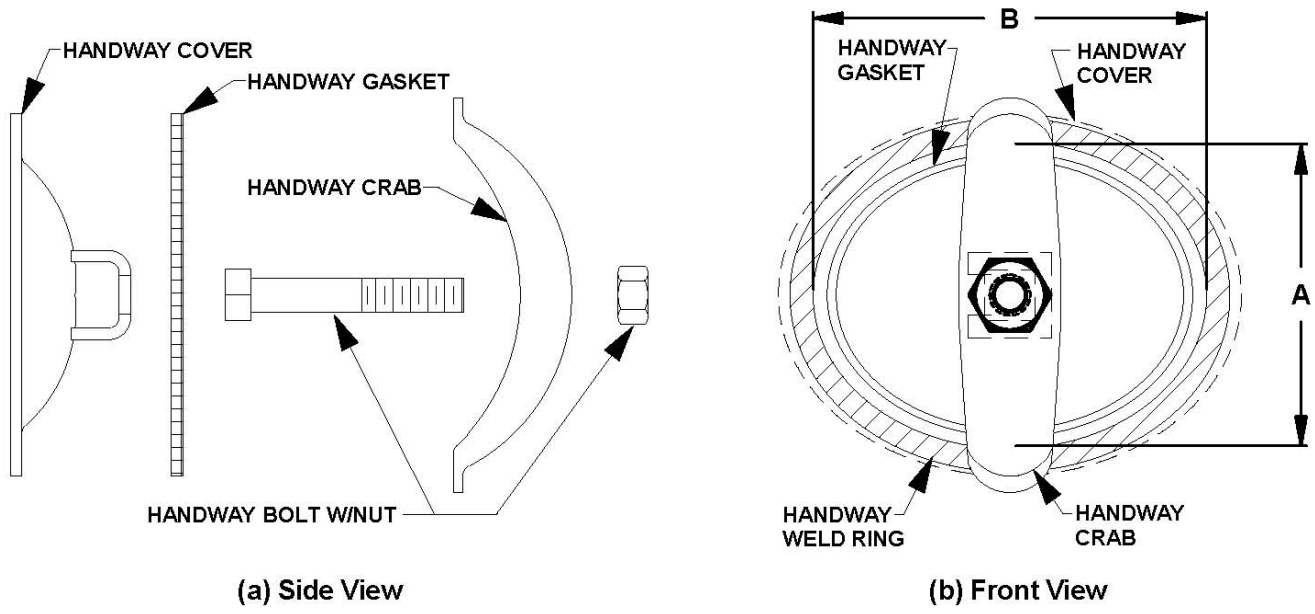

Figure 6.3 (a) – Handway Assembly

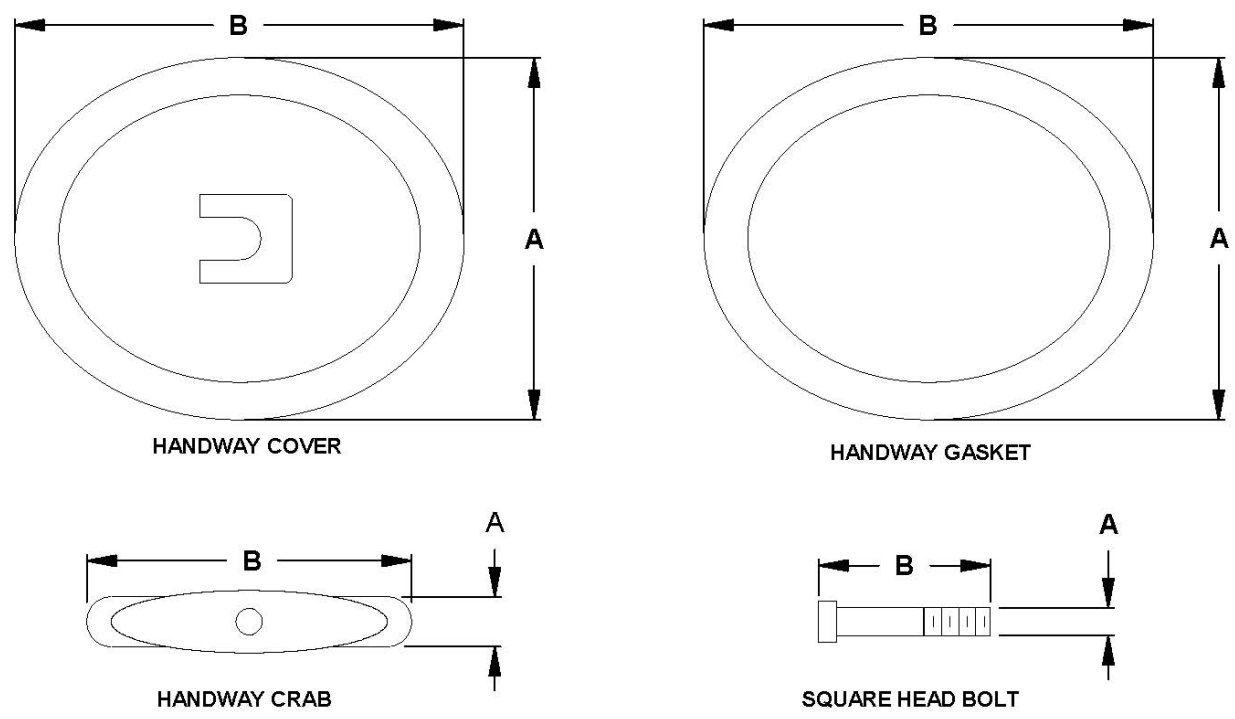

Figure 6.3 (b) – Handway Components

6" x 8" Handway Dimensions		
Component	A	B
Weld Ring	6-5/8"	8-1/2"
Handway Cover	7-11/16"	9-7/8"
Handway Gasket	7-3/4"	9-3/4"
Handway Crab	2-3/8"	8-3/4"
Square Head Bolt	3/4"-10 UNC	4-1/2"

Table 6.3 (c) – Handway Component Dimensions

7.2 Beginning the Blasting Operation (See Figure 7.1 or 7.2)

- 7.2.1. The abrasive blaster must be properly setup and all operating personnel must be thoroughly trained before beginning the blast operation. All operators must completely read and understand all sections of this manual before beginning the blast operation. See the pre-operation setup procedures given in Section 6.0.
- 7.2.2. Perform the required inspections and maintenance before beginning the blast operation. See the instructions given in Section 8.0.



The abrasive blaster is a Pressurized Vessel. Propelled objects will cause serious injury or death. Depressurize vessel before performing any maintenance. See Section 6.2.

- 7.2.3. Open the abrasive shutoff valve (optional, see Section 5.13).
- 7.2.4. Open the choke valve (#13). Leave the choke valve completely open at all times while blasting. Close the choke valve only for the “choke” procedure (see Section 11.3.2.). Do Not blast for long periods with the choke valve partially closed since this will cause excessive wear in the MV2 Valve (#14).
- 7.2.5. For initial startup the MV2 Valve (#14) should only be partially open. Turn the valve knob clockwise to completely close, then turn counterclockwise about four turns to partially open. The best setting for the valve varies depending on abrasive type, blast pressure, and nozzle size; therefore, it may take more than one adjustment to achieve the desired air/abrasive mixture. Further adjustment can be made later as needed.
- 7.2.6. Slowly open the inlet ball valve (#3). This will supply air to the Combo Valve (#4) and the deadman controls (#12 & #15). The blast vessel will not pressurize.
- 7.2.7. Slightly open the ball valve (#8) on bottom of the moisture trap (#7) to permit moisture to continually drain during the blast operation (optional, see Section 5.4). Once each day completely open the drain ball valve to blow out all moisture and dirt particles.
- 7.2.8. The following steps are for abrasive flow setting which may require several adjustments and testing of the blast flow. It is recommended that testing of the blast be made on a test piece so not to damage anything of value.
- 7.2.9. With one hand grip the blast hose assembly (#10) and with the other hand press in the deadman safety button. To begin blasting, aim the blast nozzle at the object to be blasted, then firmly press down the deadman lever (#12). The Combo Valve will open and pressurize the abrasive blaster. Air and blast abrasive will flow into the blast hose and out through the blast nozzle (#11).



Do Not aim the blast nozzle towards yourself or any person. A system malfunction or a blocked blast nozzle that clears can trigger accidental start up resulting in injury to personnel.

- 7.2.10. Observe the blast stream and the coating removal rate. A bluish color in the blast stream indicates a good abrasive to air mixture. Release the deadman lever to stop blasting.

- 7.2.11. If necessary adjust the abrasive flow with the knob on the MV2 Valve (#14). Turn clockwise for less abrasive flow, or turn counter-clockwise for more abrasive. Due to the length of the blast hose there will be a slight delay in control of the abrasive flow at the nozzle, therefore allow a few seconds before adjusting further.
- 7.2.12. Note the orifice indicator on the side of the MV2 Valve body to view the knob position relative to the abrasive flow. The VPI position can be used as reference when changing nozzle size or abrasive for different applications.
- 7.2.13. Re-test the blast air and abrasive mixture again on a test piece to determine if further adjustment is needed.
- 7.2.14. At initial blasting have an assistant check the popup, handway, hoses, and piping for leaks while the blaster is pressurized. Periodically check for leaks thereafter.
- 7.2.15. Release the deadman lever to stop blasting. The MV2 Valve blaster will depressurize.

⚠ WARNING

Airborne particles and loud noise hazards from blowdown exhaust air can cause serious injury and loss of hearing. Wear approved eye and ear protection. Stay clear of blowdown air path. DO NOT place hands or other body parts in the blowdown air path. Make sure no personnel are in the blowdown air path.

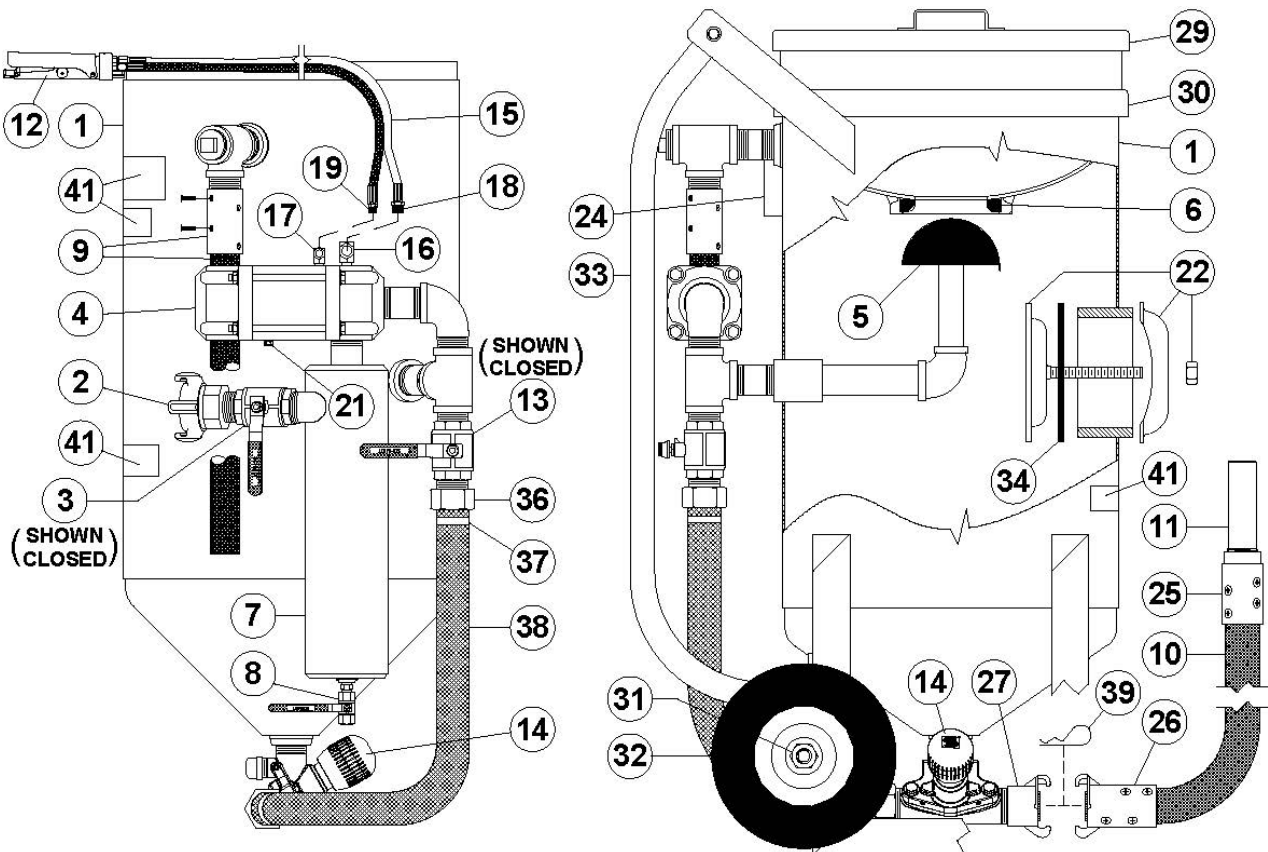

Figure 7.2 – MV2 Valve Abrasive Blaster with pneumatic blast controls

7.3 Ending the Blast Operation (See Figure 7.3)

- 7.3.1. Close the air inlet ball valve (#3). The ball valve is closed when the handle is fully turned to the position shown in Figure 7.3 (handle perpendicular to body). The handle tab will bottom against the ball valve body in the closed position.

CAUTION

Do not turn off the air compressor and allow the abrasive blaster air pressure to back flow through the air supply system. Back flow will carry abrasive into the moisture trap (#7) and contaminate the controls.

- 7.3.2. Completely open the drain ball valve (#8) at the bottom of the moisture trap (#7) to allow all the accumulated moisture to be drained out. Close the ball valve after draining.

- 7.3.3. Completely depressurize the abrasive blast vessel (#1). MV2 Valve blasters automatically depressurize when the deadman valve (#12) is released to stop blasting. See Section 6.2 for blowdown procedure.

WARNING

Airborne particles and loud noise hazard from the blowdown exhaust air can cause serious injury and loss of hearing. Wear approved eye and ear protection. Stay clear of blowdown air path. DO NOT place hands or other body parts in the blowdown air path. Make sure no personnel are in the blowdown air path.

- 7.3.4. For long periods of non-usage remove remaining blast abrasive from blast vessel to minimize moisture contamination. Replace lid (#29) to prevent debris from entering blast vessel (#1).

CAUTION

Steel abrasive left inside the blast vessel can be contaminated by moisture and solidify inside causing costly damage.

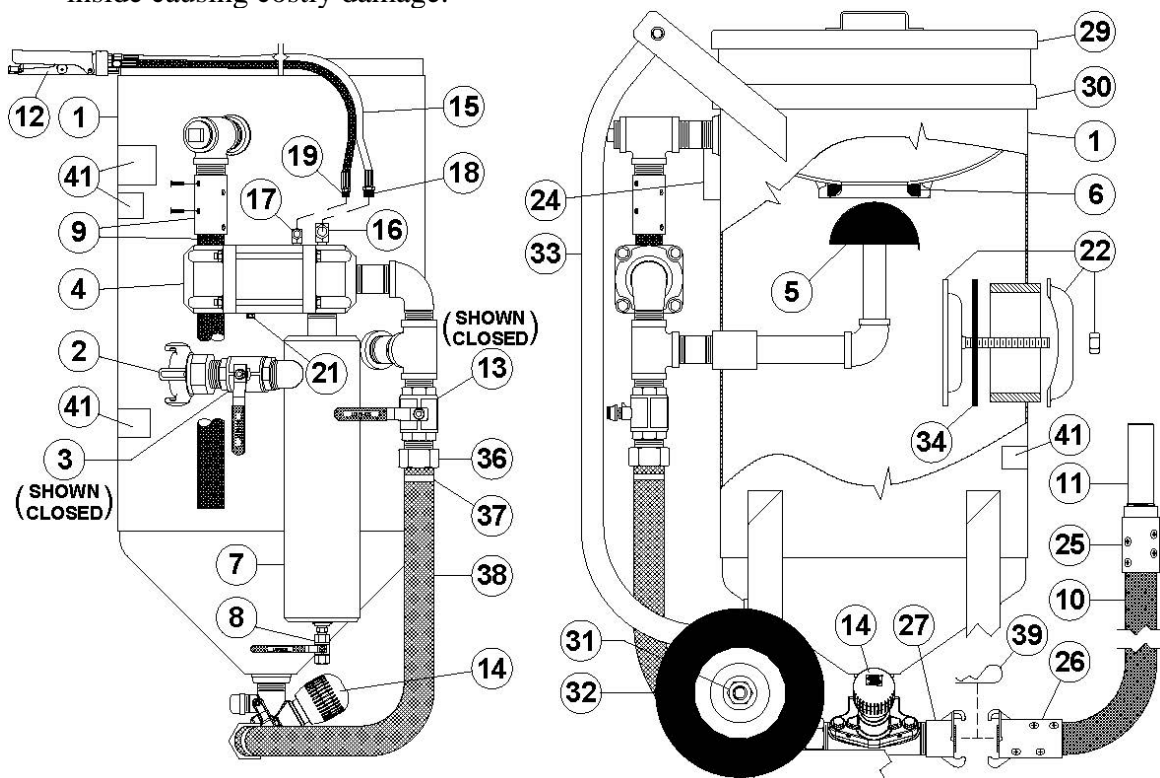

Figure 7.3 – MV2 Valve Abrasive Blaster with pneumatic blast controls

8.0 Maintenance and Inspection Instructions

DANGER

The MV2 Valve abrasive blaster is a Pressurized Vessel. Propelled objects will cause serious injury or death. Depressurize vessel before performing any maintenance. See Section 6.2.

WARNING

For proper operation, maintenance should be performed with the assistance of a qualified serviceman.

- 8.1. **Blaster Pressure Vessel:** The ASME Code is a standard covering materials, design, fabrication, and installation. Vessel integrity subsequent to purchase is the responsibility of the owner and/or user. At intervals required by state law and/or local authorities, the vessel should be subjected to a hydrostatic test as described in the ASME Code, Section VIII, Division 1. Do Not subject the abrasive blaster pressure vessel to a pneumatic proof test exceeding the maximum allowable working pressure. In no case should the hydrostatic test pressure exceed 1.3 times the maximum allowable working pressure (MAWP) shown on the pressure vessel nameplate (#24). Thoroughly clean and dry the vessel before re-assembly. Moisture or debris left in vessel can cause equipment malfunction.
- 8.2. **Blaster Pressure Vessel:** Any damage to an abrasive blaster can make it unsafe. Inspect the exterior of the abrasive blast vessel weekly for corrosion, pitting, or other damage (i.e. dents, gouges or bulges). If damaged, take out of service immediately and have it inspected and/or repaired by a qualified facility. Contact Axxiom Manufacturing, Inc. for technical support.
- 8.3. **Blaster Pressure Vessel:** The interior condition of the abrasive blast vessel (#1) should be inspected quarterly. Pitting caused by corrosion will reduce the wall thickness of the vessel. If excessive corrosion is found, have the abrasive blast vessel inspected by a qualified facility. Contact Axxiom Manufacturing, Inc. for technical support. Refer to the ASME Data Report for the vessel minimum thickness.

Check the pressure vessel internal piping for corrosion, cracks, wear, holes, or any other damage. Repair or replace damaged components. See Figure 8.1.
- 8.4. **Popup Assembly:** The popup alignment and operation is tested by the manufacturer, however vibration and creeping during shipment may cause the internal popup support piping to shift resulting in misalignment. Check the popup gap and alignment prior to initial usage and weekly thereafter. Inspect the popup as follows:
 - a) Depressurize the abrasive blaster per Section 6.2.
 - b) Disconnect air supply hose from the crowfoot (#2).
 - c) Inspect the popup gasket (#6) and popup head (#5) sealing surfaces for wear or deformations. Replace either if necessary.
 - d) Check that the popup is centered within the gasket opening. If necessary, use a pry bar as a lever between the popup and gasket to deflect the internal support piping and shift the popup to the center of the gasket opening.
 - e) Check the popup gap (distance between the popup surface and the gasket). It should be between 5/8" and 7/8". See Figure 8.1. An excessive gap is created by a vertical nipple that is too short. An excessive gap will expose the top of the vertical nipple to abrasive when the popup closes which could result in premature wear to the popup.
 - f) After checking the alignment and gap, the blast vessel can be re-pressurized and the popup is then checked for leaks. If a leak is present, repeat the above steps to isolate the problem.

WARNING

Pinch point hazard. Vessel pressurization will close the popup. Keep hands and fingers away from popup. Disconnect air supply prior to performing popup maintenance.

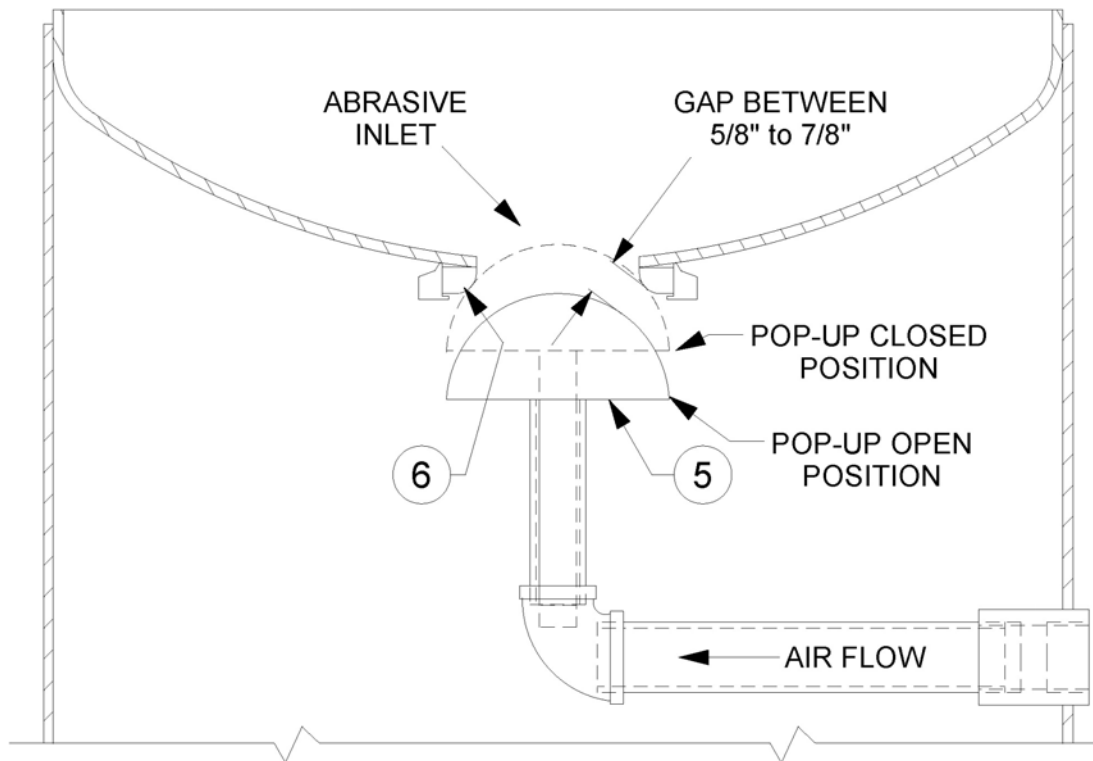

Figure 8.1 – Standard Popup Assembly and Internal Piping

- 8.6. ***Blast and Air Hoses, Piping, Pipe Fittings, and Wires:*** All air hoses, blast hoses, control hoses, pipe, pipe fittings, and wires are wear items on any abrasive blaster. These components should be inspected daily for air leaks, cracks, holes, dry rotting, cuts, or any other damage. Repair or replace any components that show any signs of wear or damage.

⚠ DANGER

Damaged hoses, piping, pipe fittings or wires can cause system malfunctions and can result in serious injury or death to operating personnel.

Blast hoses are a high wear component of the abrasive blast system. Sharp bends in the blast hose create high wear points resulting in soft spots that can rupture while blasting. Check the full length of the blast hose assembly for soft spots caused by wear. To protect against serious injury to personnel replace blast hoses with soft spots. **Note:** Static electricity is generated by the abrasive flow through the blast hose. To protect against static electrical shock to operating personnel only use static dissipating blast hose and properly ground the abrasive blaster.

⚠ WARNING

Worn blast hose assemblies can rupture while blasting and the resulting abrasive blast stream can cause serious personal injury.

⚠ WARNING

Longer blast hoses require longer time to dissipate the blast stream when the deadman is released to end the blast operation. This extended dissipation time increases the risk of injury if there is an accidental loss of control of the blast hose.

⚠ CAUTION

Static electric shock hazard. To minimize the chance of static electric shock install a grounding strap on the abrasive blaster and only use static dissipating blast hose.

- 8.7. **Blast and Air Hose Couplings:** All air hose, blast hose, and threaded couplings have pin holes that align when connected. To protect against accidental hose disconnections safety pins must be installed through these holes. Each hose connection must also include a hose whip check that will hold the hose if there is an accidental disconnection. Connect one loop to each side of the connection and stretch out as shown in Figure 8.2 below. Check hose connections daily and replace missing or damaged pins and whip checks.

⚠ WARNING

Failure to install safety pins on all air and blast hose couplings can result in hose disconnects and could result in serious injury or death.

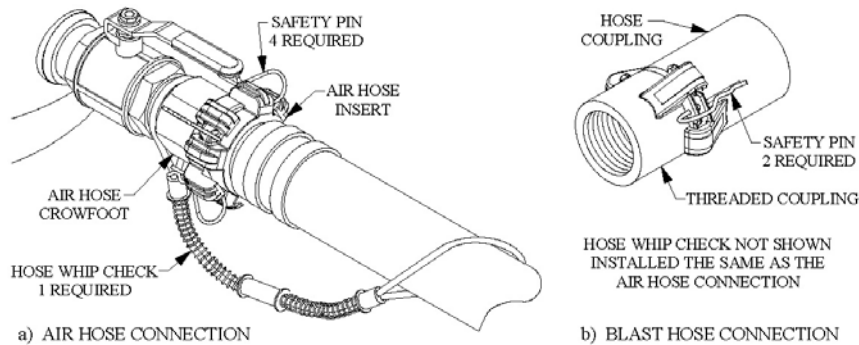

Figure 8.2 – Hose Connection Disconnect Protection

- 8.8. **Blast and Air Hose Gaskets:** All air hose, blast hose, and threaded couplings have gaskets that seal the connection. To reduce loss of air pressure and/or premature abrasive wear replace these gaskets when leaks are found. Inspect the couplings daily for leaks and wear. Replace gaskets when visible wear or leaks are found. When installing or replacing hose couplings cut the hose end square for secure fit (see Figure 8.3). To insure proper coupling connection always use fittings that are the same brand. See the drawings and part lists in Section 9.0.

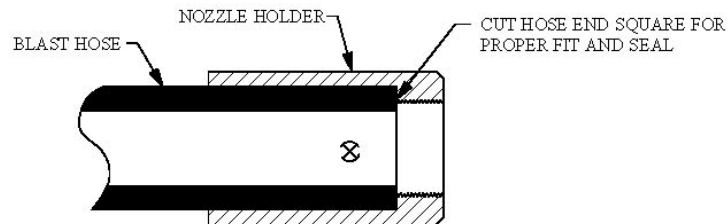

Figure 8.3 – Hose End Fit up

- 8.9. **Blast Nozzle:** Remove the blast nozzle daily and check the jacket and thread condition. Check nozzle throat diameter. An over-sized throat diameter reduces blast efficiency. Replace the blast nozzle if worn or damaged.
- 8.10. **Valves:** MV2 Valve, Combo Valve®, control valves, and deadman valves should be disassembled and inspected quarterly, or more frequently if heavily used. Ball valves should open and close without difficulty and should not leak air. Repair or replace any component that shows signs of damage. Replace parts as needed with Schmidt® original factory replacement parts furnished by an authorized Schmidt distributor. Refer to valve drawings in Section 9.0.

⚠ DANGER

Depressurize vessel before performing any maintenance. See Section 6.2. Removing components with the abrasive blaster pressurized will result in serious injury or death.

⚠ WARNING

Use of replacement components that are not Schmidt original factory replacement parts may result in equipment failure which can result in serious personal injury.

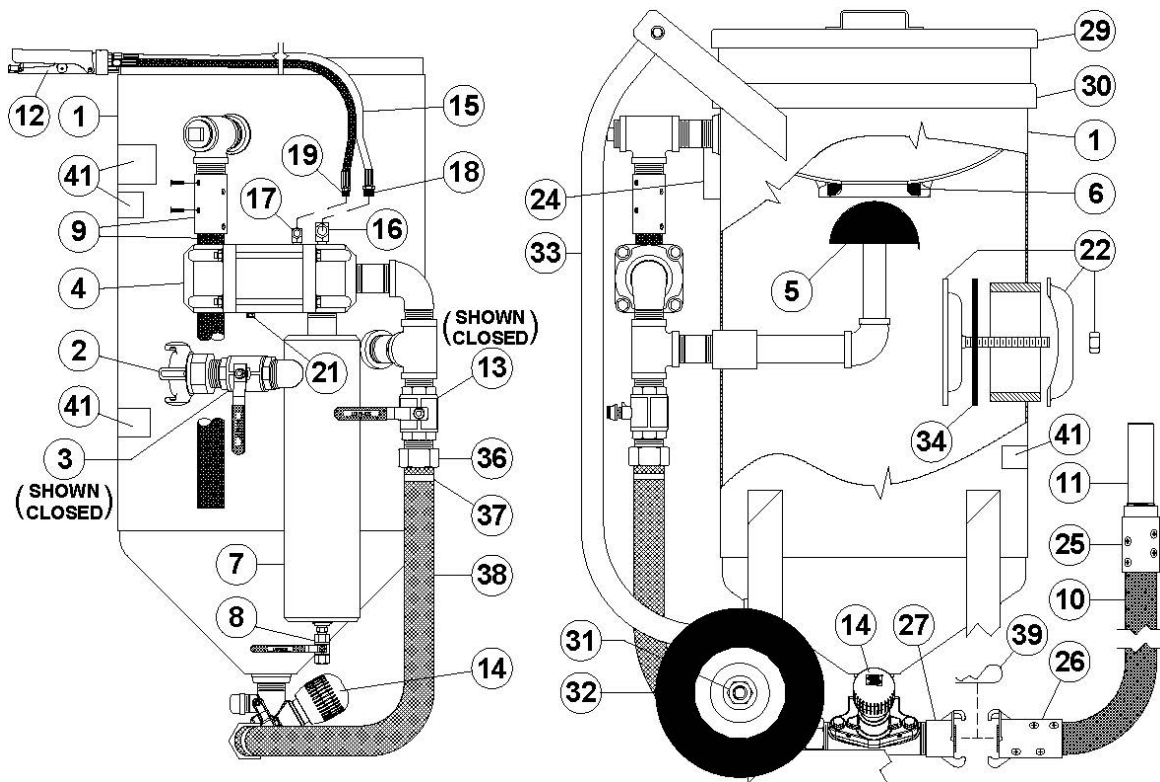

Figure 8.4 – MV2 Valve Abrasive Blaster with pneumatic blast controls

- 8.11. **Combo Blowdown Hose:** The blowdown hose (#9) that passes through the combo valve (#4) is a 3/4" blast hose. Abrasive carry-over can wear a hole through the wall of the hose and the fittings upstream. See Figure 8.4. Depressurize the abrasive blaster per Section 6.2 and check hose condition weekly. Replace as needed. When replacing the blowdown hose (#9), also replace the pipe fittings upstream of the valve. These fittings are the 1-1/4" x 3" VBS Restrictor, 1-1/4" tee, and the 1-1/4" pipe plug (see Figure 8.4).
- 8.12. **VBS Blowdown System:** Remove monthly and check for internal wear of components. Replace worn components as needed. See drawing in Section 9.10.
- 8.13. **PPE:** Check daily to verify that all personal protective equipment is available for each blast operator. Check daily to verify that all personal protective equipment is in good operating condition. Consult the operating and maintenance instructions provided by the manufacturer of each PPE item. See Section 3.10 and reference OSHA 29 CFR 1910 Subpart I.

⚠ WARNING

Failure to use personal protective equipment could result in serious injury or death.

- 8.14. **Warning Decals:** Check monthly to verify that all the warning decals are in position and legible. See Section 0.0 for full descriptions and locations.

⚠ DANGER

Failure to maintain warning decals risks the possibility of not alerting the abrasive blaster operator to potential dangers which can result in serious injury or death. See Section 0.0.

- 8.15. **Handway Assembly:** Refer to Section 6.3 for installation and inspection procedures.

8.16. **Maintenance Schedule Quick Reference Chart**

Note: The below schedule is the minimum requirements for inspection and maintenance; however, the equipment should be inspected and serviced immediately if abnormal operation is detected.

SMALL POT ABRASIVE BLASTER MAINTENANCE SCHEDULE					
Item	Maintenance Required	Daily	Weekly	Monthly	Quarterly
Blaster Vessel	Hydrostatic Test See Section 8.1	As required by state law and/or local authorities			
Blaster Vessel	Check for exterior damage (corrosion, dents, bulges). See Section 8.2		X		
Blaster Vessel	Check for interior wear, corrosion, & pitting. Check internal piping for wear or damage. See Section 8.3				X
Popup	Check sealing surfaces, alignment and gasket to popup gap. See Section 8.4		X		
Blast & Air Hoses	Check air & blast hoses for soft spots, wear, cracks, or air leaks See Section 8.6	X			
Remote Control Hoses	Check control air hoses for soft spots, wear, cracks, or air leaks See Section 8.6	X			
Blaster Piping & Pipe Fittings	Check pipe & pipe fittings for wear, cracks, or air leaks See Section 8.6	X			
Remote Control Wires	Check wiring for bare spots, fraying, cuts, or cracks See Section 8.6	X			
Blast & Air Hose Couplings	Check for safety pins and whip checks See Section 8.7	X			
Hose Coupling Gaskets	Check for leaks at the air, blast, & and threaded hose coupling gaskets See Section 8.8	X			
Blast Nozzle	Check blast nozzle threads and jacket for wear, damage, or air leaks. See Section 8.9	X			
Valves	Disassemble, inspect, and lubricate. Check for proper operation. See Section 8.10				X
Combo Valve Blowdown Hose	Check blowdown hose for wear or thinning. Check pipe tee, plug, and nipple for wear. See Section 8.11.		X		
VBS System	Check VBS internal components for wear. See Sections 9.10 and 8.12.			X	
Personal Protective Equipment	Check for presence and condition of all personal protective equipment. See Sections 3.10 and 8.13.	X			
Warning Decals	Check for presence and condition of all warning decals. See Sections 0.0 and 8.14			X	
Handway Assembly	Check condition of gasket and sealing surfaces See Sections 6.3 and 8.15.			X	

THIS PAGE INTENTIONALLY BLANK

9.0 Drawings and Parts Lists

The following pages contain drawings representing typical blast control systems and components. Determine the type of control system the abrasive blast system is equipped with (pneumatic or electric controls) then reference the appropriate drawing and parts list to determine the required parts. To insure the proper operation of the blast system only use Schmidt® original factory replacement parts furnished by an authorized Schmidt distributor. See Section 1.37 and Section 12.2.12.

9.1 MV2 Valve Abrasive Blaster Pneumatic Control (1.5 cu. ft.)

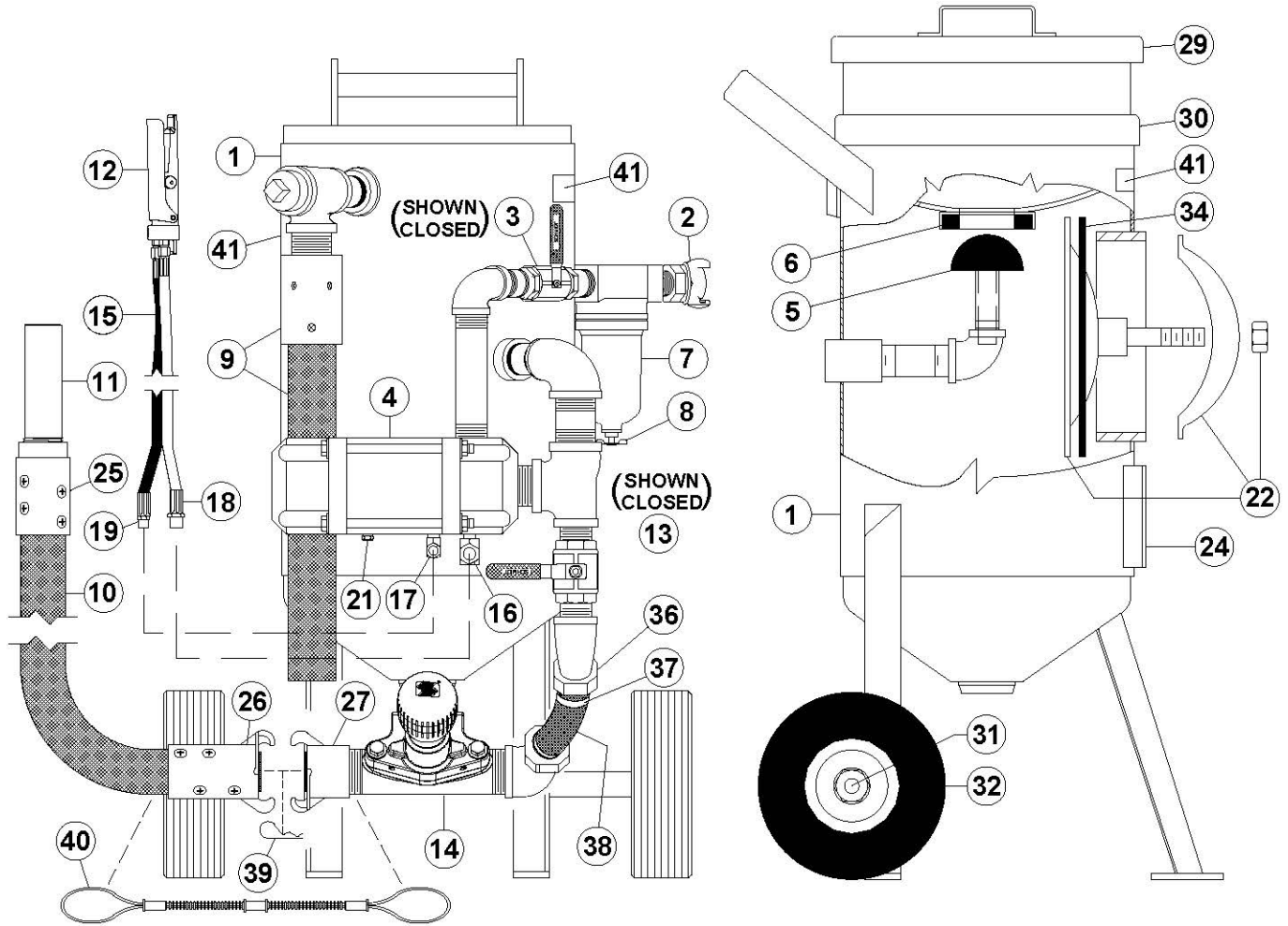

1" MV2 Valve Piping

ITEM	PART NUMBER	DESCRIPTION
1	1021-001-01	Pressure vessel, 1.5 cu. Ft.
2	4208-106	Crowfoot, 1" 2-lug with gasket
	4209-999	Crowfoot gasket
3	2401-506	Air inlet ball valve, 1"
4	2223-000	Combo Valve (See Section 9.10)
5	2100-000	Popup head, 1 bag
6	2100-001	Popup gasket, 1 bag
7	2302-206-05	Air filter, 1"
8	-----	Air filter drain valve
9	4115-005	Blowdown hose assembly, 3/4" x 18"
10	4104-XXX-XX	Blast hose assembly (specify size)
11	5000-XXX	Blast nozzle (specify size)
12	2263-002	G2 Deadman valve (See Section 9.15)
13	2401-506	Choke ball valve, 1"
14	2127-107	Micro Valve II, 1-1/4" (See Section 9.9)
15	4100-501	Twinline hose assembly, 55 ft
	4100-701	Twinline hose assembly, 110 ft
16	4203-502-02	Swivel 90°, 1/4"
17	4203-500-00	Swivel 90°, 1/8"
18	-----	Twinline connection, 1/4"
19	-----	Twinline connection, 1/8"
20	-----	-----
21	2014-300	Breather vent, 1/8"

ITEM	PART NUMBER	DESCRIPTION
22	7000-001-11	Handway crab assembly, 6" x 8"
23	-----	-----
24	-----	Pressure vessel nameplate
25	4215-XXX	Nozzle holder (specify size)
26	4213-XXX	Blast hose coupling (specify size)
27	4214-108-01	Threaded coupling, 1-1/4" with gasket
	4214-999	Coupling gasket
28	-----	-----
29	5010-010	Lid, 12" (Optional)
30	5011-010	Screen, 12" (1/4" mesh) (Optional)
31	7040-003	Axle, 1 bag (as of April, '95)
	7019-519	Nylock nut, 3/4"
32	7046-002	Wheel, 1 bag
33	-----	-----
34	7000-001-06	Handway gasket 6" x 8"
35	-----	-----
36	4205-106	Hose insert swival, 1" with gasket
	4205-106-99	Hose swival gasket, 1"
37	4235-006	Hose clamp double bolt, 1"
38	4102-006	Air hose, 1"
39	7119-002	Safety Pin, Air/Blast Hose Coupling
40	8710-98778	Hose whip check (safety cable)
41	7031-999-02	Warning decal kit

9.2(a) MV2 Valve Abrasive Blaster Pneumatic Control (3.5 - 20 cu. ft.)

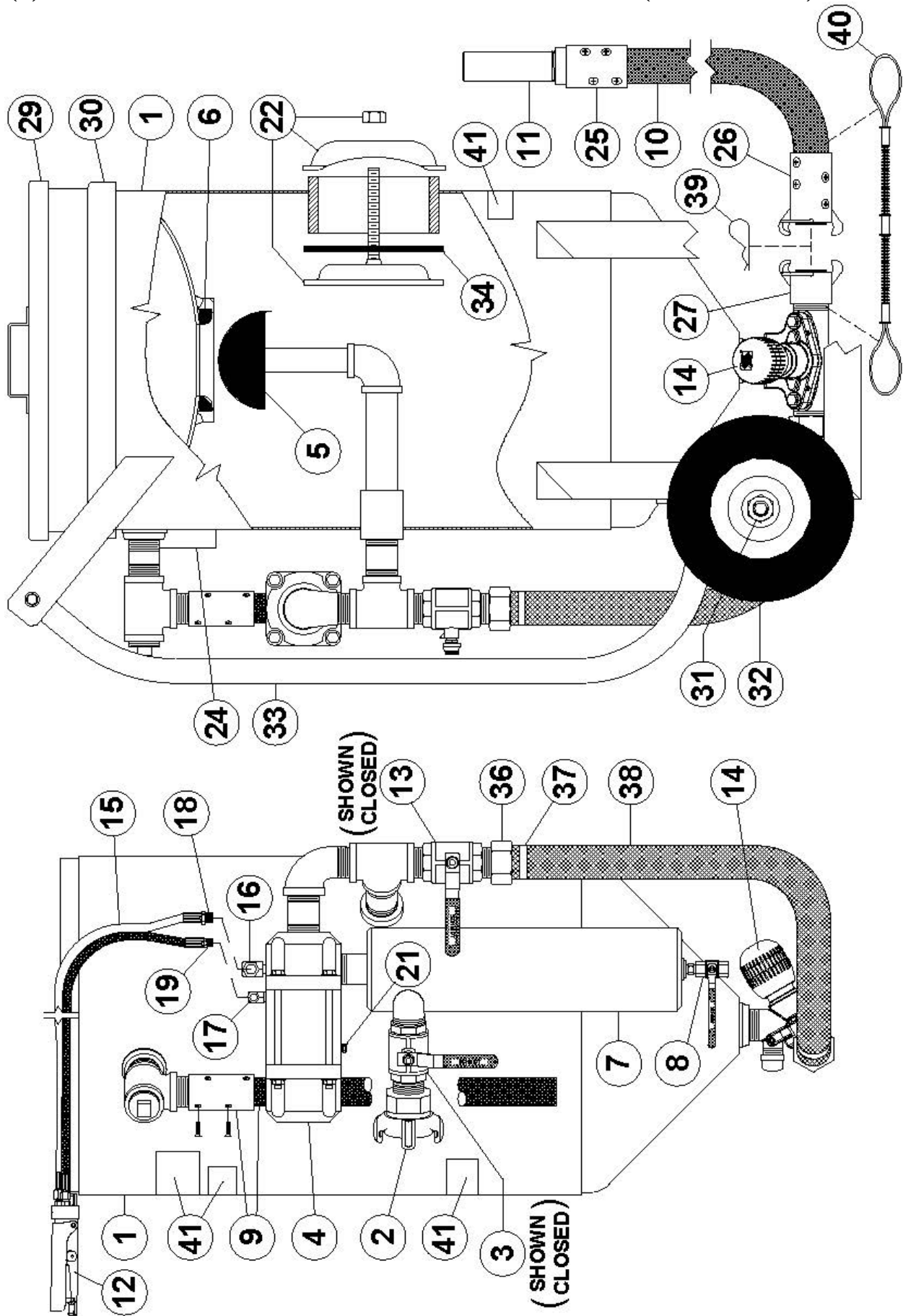

9.2(b) MV2 Abrasive Blaster Pneumatic Control Parts List (3.5 - 20 cu. ft.)

1" Microvalve Piping		
ITEM	PART NUMBER	DESCRIPTION
1	1021-003-01	Pressure vessel, 3.5 cu.ft. (150 psi)
	1021-006-01	Pressure vessel, 6.5 cu.ft. (150 psi)
	1022-010-01	Pressure vessel, 10 cu.ft. (150 psi)
	1012-020-06	Pressure vessel, 20 cu.ft. (125 psi)
2	4208-106	Crowfoot, 1" 2-lug with gasket
	4209-999	Crowfoot gasket
3	2401-506	Air inlet ball valve, 1"
4	2223-000	Combo Valve (See Section 9.10)
5	2100-010	Popup head
6	2100-011	Popup gasket
7	1200-006	Moisture Separator, 1"
8	2401-502	Drain ball valve, 1/4"
9	4115-005	Blowdown hose assy, 18" (3.5/6.5 cu.ft.)
	4115-005-02	Blowdown hose assy, 24" (10 cu.ft.)
10	4104-XXX-XX	Blast hose assembly (specify size)
11	5000-XXX	Blast nozzle (specify size)
12	2263-002	G2 Deadman valve (See Section 9.15)
13	2401-506	Choke ball valve, 1"
14	2127-107	Microvalve II, 1-1/4" (See Section 9.9)
15	4100-501	Twinline hose assembly, 55 ft
	4100-701	Twinline hose assembly, 110 ft
16	4203-502-02	Swivel 90°, 1/4"
17	4203-500-00	Swivel 90°, 1/8"
18	-----	Twinline connection, 1/4"
19	-----	Twinline connection, 1/8"
20	-----	-----
21	2014-300	Breather vent, 1/8"
22	7000-001-11	Handway assembly, 6" x 8" with gasket
23	-----	-----
24	-----	Pressure vessel nameplate
25	4215-XXX	Nozzle holder (specify size)
26	4213-XXX	Blast hose coupling (specify size)
27	4214-108-01	Threaded coupling, 1-1/4" with gasket
	4214-999	Coupling gasket
28	-----	-----
29	5010-030	Lid, 18" (optional)
	5010-060	Lid, 24" (optional)
	5010-200	Lid, 36" (optional)
30	5011-030	Screen, 18" (1/4" mesh) (Optional)
	5011-060	Screen, 24" (1/4" mesh) (Optional)
	5011-200	Screen, 36" (1/4" mesh) (Optional)
31	7040-003	Axle, 3.5 cu.ft.
	7019-519	Nylock nut, 3/4" (3.5 cu ft)
	7040-006	Axle, 6.5/10 cu.ft.
	7019-527	Nylock nut, 1" (6.5/10 cu ft)
	-----	not available for 20 cu.ft.
32	7046-003	Wheel, 3.5 cu.ft.
	7046-006	Wheel, 6.5/10 cu.ft.
	-----	not available for 20 cu.ft.
33	7002-003	Load skid, 3.5 cu ft
	7002-006	Load skid, 6.5 cu ft
	7002-010	Load skid, 10 cu ft
	-----	not available for 20 cu.ft.
34	7000-001-06	Handway gasket 6" x 8"
35	-----	-----
36	4205-106	Swivel insert, 1" with gasket
	4205-106-99	Insert gasket
37	4235-006	Hose clamp, double bolt 1"
38	4102-006	Air hose, 1"
39	7119-002	Safety pin, air/blast hose coupling
40	8710-98778	Hose whip check (safety cable)
41	7031-999-02	Warning decal kit

1 1/4" Microvalve Piping		
ITEM	PART NUMBER	DESCRIPTION
1	1021-003-01	Pressure vessel, 3.5 cu.ft. (150 psi)
	1021-006-01	Pressure vessel, 6.5 cu.ft. (150 psi)
	1022-010-01	Pressure vessel, 10 cu.ft. (150 psi)
	1012-020-06	Pressure vessel, 20 cu.ft. (125 psi)
2	4211-107	Crowfoot, 1-1/4" 4-lug with gasket
	4211-999	Crowfoot gasket
3	2401-507	Air inlet ball valve, 1-1/4"
4	2223-000	Combo Valve (See Section 9.10)
5	2100-010	Popup head
6	2100-011	Popup gasket
7	1200-007	Moisture Separator, 1-1/4"
8	2401-502	Drain ball valve, 1/4"
9	4115-005	Blowdown hose assy, 18" (3.5/6.5 cu.ft.)
	4115-005-02	Blowdown hose assy, 24" (10 cu.ft.)
10	4104-XXX-XX	Blast hose assembly (specify size)
11	5000-XXX	Blast nozzle (specify size)
12	2263-002	G2 Deadman valve (See Section 9.15)
13	2401-507	Choke ball valve, 1-1/4"
14	2127-107	Microvalve II, 1-1/4" (See Section 9.9)
15	4100-501	Twinline hose assembly, 55 ft
	4100-701	Twinline hose assembly, 110 ft
16	4203-502-02	Swivel 90°, 1/4"
17	4203-500-00	Swivel 90°, 1/8"
18	-----	Twinline connection, 1/4"
19	-----	Twinline connection, 1/8"
20	-----	-----
21	2014-300	Breather vent, 1/8"
22	7000-001-11	Handway assembly, 6" x 8" with gasket
23	-----	-----
24	-----	Pressure vessel nameplate
25	4215-XXX	Nozzle holder (specify size)
26	4213-XXX	Blast hose coupling (specify size)
27	4214-108-01	Threaded coupling, 1-1/4" with gasket
	4214-999	Coupling gasket
28	-----	-----
29	5010-030	Lid, 18" (optional)
	5010-060	Lid, 24" (optional)
	5010-200	Lid, 36" (optional)
30	5011-030	Screen, 18" (1/4" mesh) (Optional)
	5011-060	Screen, 24" (1/4" mesh) (Optional)
	5011-200	Screen, 36" (1/4" mesh) (Optional)
31	7040-003	Axle, 3.5 cu.ft.
	7019-519	Nylock nut, 3/4" (3.5 cu ft)
	7040-006	Axle, 6.5/10 cu.ft.
	7019-527	Nylock nut, 1" (6.5/10 cu ft)
	-----	not available for 20 cu.ft.
32	7046-003	Wheel, 3.5 cu.ft.
	7046-006	Wheel, 6.5/10 cu.ft.
	-----	not available for 20 cu.ft.
33	7002-003	Load skid, 3.5 cu ft
	7002-006	Load skid, 6.5 cu ft
	7002-010	Load skid, 10 cu ft
	-----	not available for 20 cu.ft.
34	7000-001-06	Handway gasket 6" x 8"
35	-----	-----
36	4205-107	Swivel insert, 1 1/4" with gasket
	4205-107-99	Insert gasket
37	4235-007	Hose clamp, double bolt 1 1/4"
38	4102-007	Air hose, 1-1/4"
39	7119-002	Safety pin, air/blast hose coupling
40	8710-98778	Hose whip check (safety cable)
41	7031-999-02	Warning decal kit

1 1/2" Microvalve Piping		
ITEM	PART NUMBER	DESCRIPTION
1	1021-003-01	Pressure vessel, 3.5 cu.ft. (150 psi)
	1021-006-01	Pressure vessel, 6.5 cu.ft. (150 psi)
	1022-010-01	Pressure vessel, 10 cu.ft. (150 psi)
	1012-020-06	Pressure vessel, 20 cu.ft. (125 psi)
2	4211-108	Crowfoot, 1 1/2" 4-lug
	4211-999	Crowfoot gasket
3	2401-508	Air inlet ball valve, 1-1/2"
4	2223-000	Combo Valve (See Section 9.10)
5	2100-010	Popup head
6	2100-011	Popup gasket
7	1200-008	Moisture Separator, 1-1/2"
8	2401-502	Drain ball valve, 1/4"
9	4115-005	Blowdown hose assy, 18" (3.5/6.5 cu.ft.)
	4115-005-02	Blowdown hose assy, 24" (10 cu.ft.)
10	4104-XXX-XX	Blast hose assembly (specify size)
11	5000-XXX	Blast nozzle (specify size)
12	2263-002	G2 Deadman valve (See Section 9.15)
13	2401-508	Choke ball valve, 1-1/2"
14	2127-108	Microvalve II, 1-1/2" (See Section 9.9)
15	4100-501	Twinline hose assembly, 55 ft
	4100-701	Twinline hose assembly, 110 ft
16	4203-502-02	Swivel 90°, 1/4"
17	4203-500-00	Swivel 90°, 1/8"
18	-----	Twinline connection, 1/4"
19	-----	Twinline connection, 1/8"
20	-----	-----
21	2014-300	Breather vent, 1/8"
22	7000-001-11	Handway assembly, 6" x 8" with gasket
23	-----	-----
24	-----	Pressure vessel nameplate
25	4215-XXX	Nozzle holder (specify size)
26	4213-XXX	Blast hose coupling (specify size)
27	4214-108-01	Threaded coupling, 1-1/2" with gasket
	4214-999	Coupling gasket
28	-----	-----
29	5010-030	Lid, 18" (optional)
	5010-060	Lid, 24" (optional)
	5010-200	Lid, 36" (optional)
30	5011-030	Screen, 18" (1/4" mesh) (Optional)
	5011-060	Screen, 24" (1/4" mesh) (Optional)
	5011-200	Screen, 36" (1/4" mesh) (Optional)
31	7040-003	Axle, 3.5 cu.ft.
	7019-519	Nylock nut, 3/4" (3.5 cu ft)
	7040-006	Axle, 6.5/10 cu.ft.
	7019-527	Nylock nut, 1" (6.5/10 cu ft)
	-----	not available for 20 cu.ft.
32	7046-003	Wheel, 3.5 cu.ft.
	7046-006	Wheel, 6.5/10 cu.ft.
	-----	not available for 20 cu.ft.
33	7002-003	Load skid, 3.5 cu ft
	7002-006	Load skid, 6.5 cu ft
	7002-010	Load skid, 10 cu ft
	-----	not available for 20 cu.ft.
34	7000-001-06	Handway gasket 6" x 8"
35	-----	-----
36	4205-108	Swivel Insert, 1-1/2" with gasket
	4205-108-99	Insert gasket
37	4235-008	Hose clamp, double bolt 1-1/2"
38	4102-008	Air hose 1-1/2"
39	7119-002	Safety pin, air/blast hose coupling
40	8710-98778	Hose whip check (safety cable)
41	7031-999-02	Warning decal kit

9.3(a) MV2 Valve Abrasive Blaster Electric Control (3.5 - 20 cu. ft.)

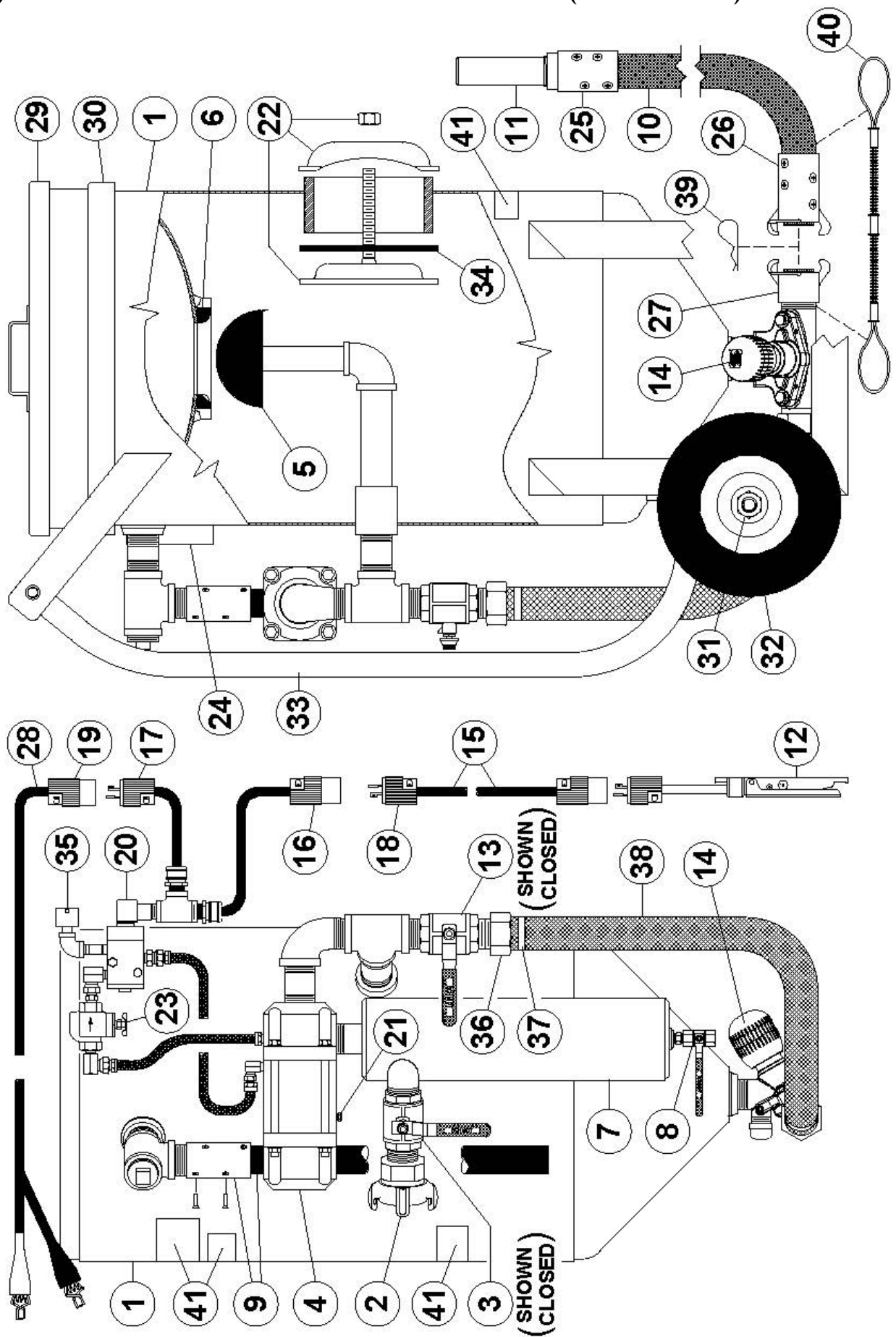

9.3(b) MV2 Valve Abrasive Blaster Electric Control Parts List (3.5 - 20 cu. ft.)

1 1/2" Microvalve Piping		
ITEM	PART NUMBER	DESCRIPTION
1	1021-003-01	Pressure vessel, 3.5 cu.ft. (150 psi)
	1021-006-01	Pressure vessel, 6.5 cu.ft. (150 psi)
	1022-010-01	Pressure vessel, 10 cu.ft. (150 psi)
	1012-020-05	Pressure vessel, 20 cu.ft. (125 psi)
2	4211-108	Crowfoot, 1 1/2" 4-lug
	4211-989	Crowfoot gasket
3	2401-508	Air inlet ball valve, 1-1/2"
4	2223-000	Combo Valve (See Section 9.10)
5	2100-010	Popup head
6	2100-011	Popup gasket
7	1200-008	Moisture Separator, 1-1/2"
8	2401-502	Drain ball valve, 1/4"
9	4115-005	Blowdown hose assy, 18" (3.5/6.5 cu.ft.)
	4115-005-02	Blowdown hose assy, 24" (10 cu.ft.)
10	4104-XXX-XX	Blast hose assembly (specify size)
11	5000-XXX	Blast nozzle (specify size)
12	2263-400	Electric deadman (See Section 9.16)
13	2401-508	Choke ball valve, 1-1/2"
14	2125-108	Microvalve II, 1-1/2" (See Section 9.9)
15	7074-055	Extension cord, 55 ft
	7074-110	Extension cord, 110 ft
16	7109-300	Female connector, 3-prong twist-lock
17	7109-301	Male plug, 3-prong twist-lock
18	7109-301	Male plug, 3-prong twist-lock
19	7109-300	Female connector, 3-prong twist-lock
20	2229-100	Control valve, 12Vdc (See Section 9.13)
	7112-000	Power tee, 12Vdc with coil & connectors
21	2014-300	Breather vent, 1/8"
22	7000-001-11	Handway assembly, 6" x 8" with gasket
23	2301-902-90	Strainer, 1/4" 90 micron
24	-----	Pressure vessel nameplate
25	4215-XXX	Nozzle holder (specify size)
26	4213-XXX	Blast hose coupling (specify size)
27	4214-108-01	Threaded coupling, 1-1/2" with gasket
	4214-989	Coupling gasket
28	7072-012	Power cord, 25ft with alligator clips
29	5010-030	Lid, 18" (optional)
	5010-060	Lid, 24" (optional)
	5010-200	Lid, 36" (optional)
30	5011-030	Screen, 18" (1/4" mesh) (Optional)
	5011-060	Screen, 24" (1/4" mesh) (Optional)
	5011-200	Screen, 36" (1/4" mesh) (Optional)
31	7040-003	Axle, 3.5 cu.ft.
	7019-519	Nylock nut, 3/4" (3.5 cu ft)
	7040-006	Axle, 6.5/10 cu.ft.
	7019-527	Nylock nut, 1" (6.5/10 cu ft)
	-----	not available for 20 cu.ft.
32	7046-003	Wheel, 3.5 cu.ft.
	7046-006	Wheel, 6.5/10 cu.ft.
	-----	not available for 20 cu.ft.
33	7002-003	Load skid, 3.5 cu ft
	7002-006	Load skid, 6.5 cu ft
	7002-010	Load skid, 10 cu ft
	-----	not available for 20 cu.ft.
34	7000-001-06	Handway gasket 6" x 8"
35	2013-402	Dust eliminator, 1/4"
36	4205-106	Swivel insert, 1" with gasket
	4205-106-99	Insert gasket
37	4235-008	Hose clamp, double bolt 1-1/2"
38	4102-008	Air hose, 1-1/2"
39	7119-002	Safety pin, airblast hose coupling
40	8710-98778	Hose whip check (safety cable)
41	7031-989-02	Warning decal kit

1 1/4" Microvalve Piping		
ITEM	PART NUMBER	DESCRIPTION
1	1021-003-01	Pressure vessel, 3.5 cu.ft. (150 psi)
	1021-006-01	Pressure vessel, 6.5 cu.ft. (150 psi)
	1022-010-01	Pressure vessel, 10 cu.ft. (150 psi)
	1012-020-05	Pressure vessel, 20 cu.ft. (125 psi)
2	4211-107	Crowfoot, 1-1/4" 4-lug with gasket
	4211-989	Crowfoot gasket
3	2401-507	Air inlet ball valve, 1-1/4"
4	2223-000	Combo Valve (See Section 9.10)
5	2100-010	Popup head
6	2100-011	Popup gasket
7	1200-007	Moisture Separator, 1-1/4"
8	2401-502	Drain ball valve, 1/4"
9	4115-005	Blowdown hose assy, 18" (3.5/6.5 cu.ft.)
	4115-005-02	Blowdown hose assy, 24" (10 cu.ft.)
10	4104-XXX-XX	Blast hose assembly (specify size)
11	5000-XXX	Blast nozzle (specify size)
12	2263-400	Electric deadman (See Section 9.16)
13	2401-507	Choke ball valve, 1-1/4"
14	2127-107	Microvalve II, 1-1/4" (See Section 9.9)
15	7074-055	Extension cord, 55 ft
	7074-110	Extension cord, 110 ft
16	7109-300	Female connector, 3-prong twist-lock
17	7109-301	Male plug, 3-prong twist-lock
18	7109-301	Male plug, 3-prong twist-lock
19	7109-300	Female connector, 3-prong twist-lock
20	2229-100	Control valve, 12Vdc (See Section 9.13)
	7112-000	Power tee, 12Vdc with coil & connectors
21	2014-300	Breather vent, 1/8"
22	7000-001-11	Handway assembly, 6" x 8" with gasket
23	2301-902-90	Strainer, 1/4" 90 micron
24	-----	Pressure vessel nameplate
25	4215-XXX	Nozzle holder (specify size)
26	4213-XXX	Blast hose coupling (specify size)
27	4214-108-01	Threaded coupling, 1-1/4" with gasket
	4214-989	Coupling gasket
28	7072-012	Power cord, 25ft with alligator clips
29	5010-030	Lid, 18" (optional)
	5010-060	Lid, 24" (optional)
	5010-200	Lid, 36" (optional)
30	5011-030	Screen, 18" (1/4" mesh) (Optional)
	5011-060	Screen, 24" (1/4" mesh) (Optional)
	5011-200	Screen, 36" (1/4" mesh) (Optional)
31	7040-003	Axle, 3.5 cu.ft.
	7019-519	Nylock nut, 3/4" (3.5 cu ft)
	7040-006	Axle, 6.5/10 cu.ft.
	7019-527	Nylock nut, 1" (6.5/10 cu ft)
	-----	not available for 20 cu.ft.
32	7046-003	Wheel, 3.5 cu.ft.
	7046-006	Wheel, 6.5/10 cu.ft.
	-----	not available for 20 cu.ft.
33	7002-003	Load skid, 3.5 cu ft
	7002-006	Load skid, 6.5 cu ft
	7002-010	Load skid, 10 cu ft
	-----	not available for 20 cu.ft.
34	7000-001-06	Handway gasket 6" x 8"
35	2013-402	Dust eliminator, 1/4"
36	4205-107	Swivel insert, 1 1/4" with gasket
	4205-107-99	Insert gasket
37	4235-007	Hose clamp, double bolt 1 1/4"
38	4102-007	Air hose, 1-1/4"
39	7119-002	Safety pin, airblast hose coupling
40	8710-98778	Hose whip check (safety cable)
41	7031-989-02	Warning decal kit

1" Microvalve Piping		
ITEM	PART NUMBER	DESCRIPTION
1	1021-003-01	Pressure vessel, 3.5 cu.ft. (150 psi)
	1021-006-01	Pressure vessel, 6.5 cu.ft. (150 psi)
	1022-010-01	Pressure vessel, 10 cu.ft. (150 psi)
	1012-020-05	Pressure vessel, 20 cu.ft. (125 psi)
2	4208-106	Crowfoot, 1" 2-lug with gasket
	4209-989	Crowfoot gasket
3	2401-506	Air inlet ball valve, 1"
4	2223-000	Combo Valve (See Section 9.10)
5	2100-010	Popup head
6	2100-011	Popup gasket
7	1200-006	Moisture Separator, 1"
8	2401-502	Drain ball valve, 1/4"
9	4115-005	Blowdown hose assy, 18" (3.5/6.5 cu.ft.)
	4115-005-02	Blowdown hose assy, 24" (10 cu.ft.)
10	4104-XXX-XX	Blast hose assembly (specify size)
11	5000-XXX	Blast nozzle (specify size)
12	2263-400	Electric deadman (See Section 9.16)
13	2401-506	Choke ball valve, 1"
14	2127-107	Microvalve II, 1-1/4" (See Section 9.9)
	3027-107-06	Ball reducer, 1-1/4" x 1" galv.
15	7074-055	Extension cord, 55 ft
	7074-110	Extension cord, 110 ft
16	7109-300	Female connector, 3-prong twist-lock
17	7109-301	Male plug, 3-prong twist-lock
18	7109-301	Male plug, 3-prong twist-lock
19	7109-300	Female connector, 3-prong twist-lock
20	2229-100	Control valve, 12Vdc (See Section 9.13)
	7112-000	Power tee, 12Vdc with coil & connectors
21	2014-300	Breather vent, 1/8"
22	7000-001-11	Handway assembly, 6" x 8" with gasket
23	2301-902-90	Strainer, 1/4" 90 micron
24	-----	Pressure vessel nameplate
25	4215-XXX	Nozzle holder (specify size)
26	4213-XXX	Blast hose coupling (specify size)
27	4214-108-01	Threaded coupling, 1-1/4" with gasket
	4214-989	Coupling gasket
28	7072-012	Power cord, 25ft with alligator clips
29	5010-030	Lid, 18" (optional)
	5010-060	Lid, 24" (optional)
	5010-200	Lid, 36" (optional)
30	5011-030	Screen, 18" (1/4" mesh) (Optional)
	5011-060	Screen, 24" (1/4" mesh) (Optional)
	5011-200	Screen, 36" (1/4" mesh) (Optional)
31	7040-003	Axle, 3.5 cu.ft.
	7019-519	Nylock nut, 3/4" (3.5 cu ft)
	7040-006	Axle, 6.5/10 cu.ft.
	7019-527	Nylock nut, 1" (6.5/10 cu ft)
	-----	not available for 20 cu.ft.
32	7046-003	Wheel, 3.5 cu.ft.
	7046-006	Wheel, 6.5/10 cu.ft.
	-----	not available for 20 cu.ft.
33	7002-003	Load skid, 3.5 cu ft
	7002-006	Load skid, 6.5 cu ft
	7002-010	Load skid, 10 cu ft
	-----	not available for 20 cu.ft.
34	7000-001-06	Handway gasket 6" x 8"
35	2013-402	Dust eliminator, 1/4"
36	4205-106	Swivel insert, 1" with gasket
	4205-106-99	Insert gasket
37	4235-006	Hose clamp, double bolt 1"
38	4102-006	Air hose, 1"
39	7119-002	Safety pin, airblast hose coupling
40	8710-98778	Hose whip check (safety cable)
41	7031-989-02	Warning decal kit

9.4 Micro Valve

	2125-106	1" Micro Valve with Urethane Sleeve
	2125-107	1 1/4" Micro Valve with Urethane Sleeve
	2125-108	1 1/2" Micro Valve with Urethane Sleeve
No.	Part No.	Description
	2125-100-99	Replacement Part Kit With Urethane Sleeve
1.	2125-000-01	Knob
2. *	2125-000-04	Roll Pin
3.	7010-505-56	Bolt
4.	2125-000-02	Cap
5. *	2125-000-05	Plunger
6.	2125-000-06	Body
7. *	2149-000-06	Plunger Seal
8. *	2125-100-08	Sleeve - Urethane
9. *	2125-000-09	Gasket
10.	2125-006-10	Pipe Nipple, 1" Female x 1 1/2" Male
	2125-007-10	Pipe Nipple, 1 1/4" Male x 1 1/2" Male
	2125-008-10	Pipe Nipple, 1 1/2" Male x 1 1/2" Male
* Included in replacement part kit		

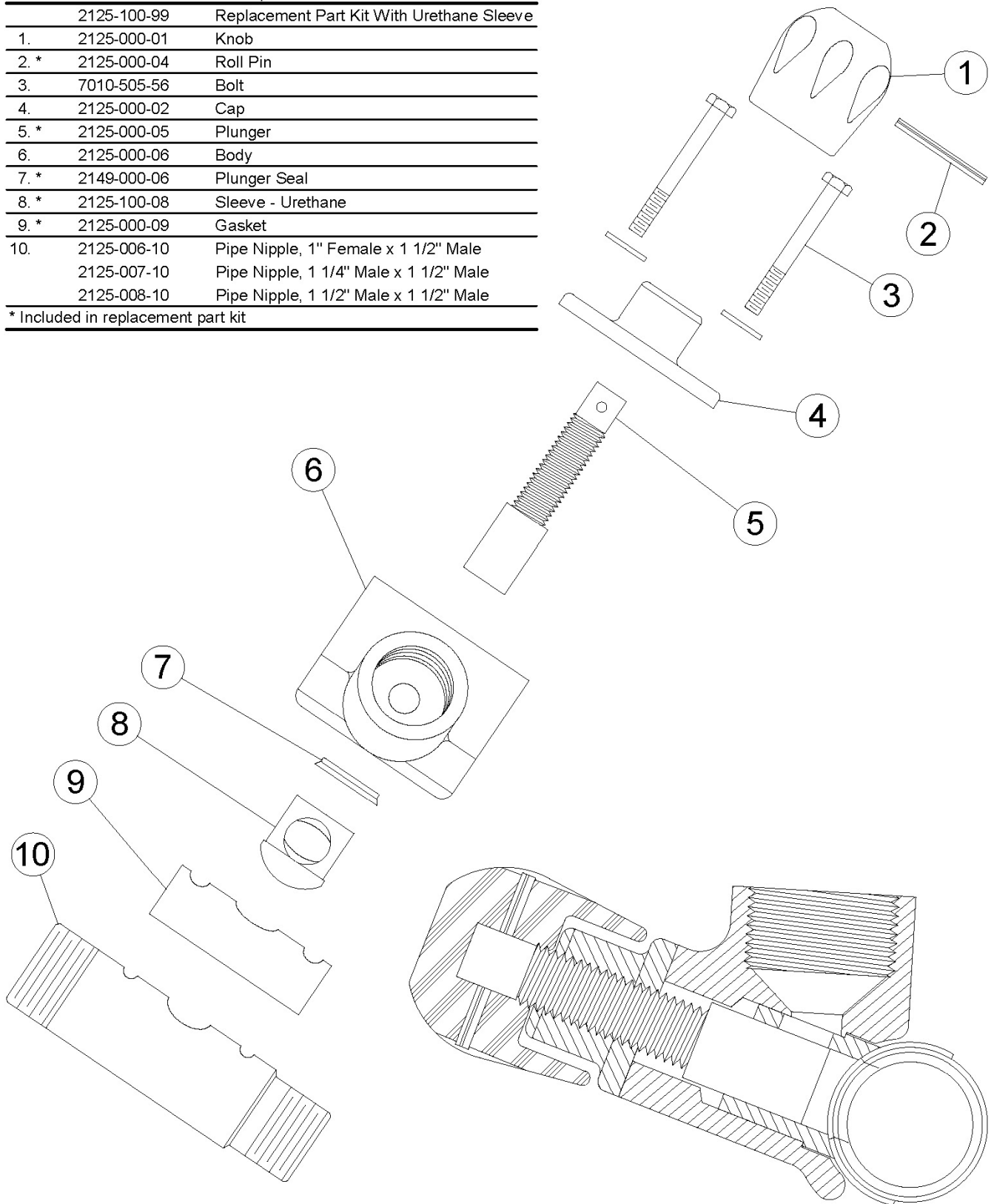

9.5 MV2 Valve

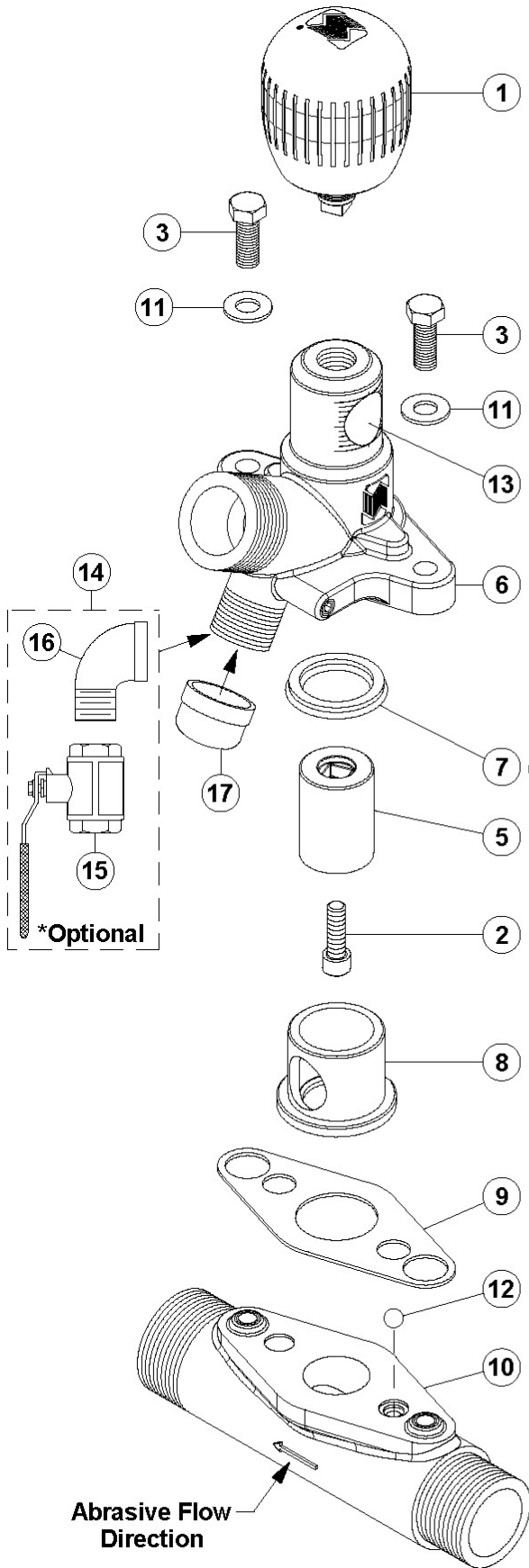

2127-107	MV2 Valve Assembly, Urethane 1-1/4" & 1"	
2127-108	MV2 Valve Assembly, Urethane 1-1/2"	
No.	Part No.	Description
	2127-100-98	Replacement Parts Kit, Seals Only
	2127-100-99	Replacement Parts Kit
1.	2127-000-01	Knob
2.*	7011-005-06O	Socket Head Cap Screw, 5/16" x 1" Self Sealing
3.	7010-507-06	Hex Bolt, 3/8" x 1" Lg.
5.*	2127-000-05	Plunger
6.	2127-000-06	Body
7.**	2149-500-06	Plunger Seal
8.**	2127-100-08	Polyurethane Sleeve
9.**	2127-000-15	Gasket
10.	2127-007-10	Base, 1 1/4"
	2127-008-10	Base, 1 1/2"
11.	7027-503-02	Flat Washer, 3/8"
12.**	2127-000-12	Ball
13.	2127-000-13	Orifice Indicator Decal
14.	2127-000-14	Cleanout Ball Valve Adder
15.	2401-505	Ball Valve, 3/4" Full Port
16.	3006-105	Street Elbow 90°, 3/4" Galv.
17.	3037-105	Pipe Cap, 3/4" Galv.
* Included In Replacement Parts Kit		
+ Included In Replacement Parts Kit, Seals Only		

Notes:
 (1) An 1-1/4" MV2 with a reducing elbow is used in 1" piping systems.
 (2) Hex bolts (item 3) should be torqued to 30-35 ft.-lbs.

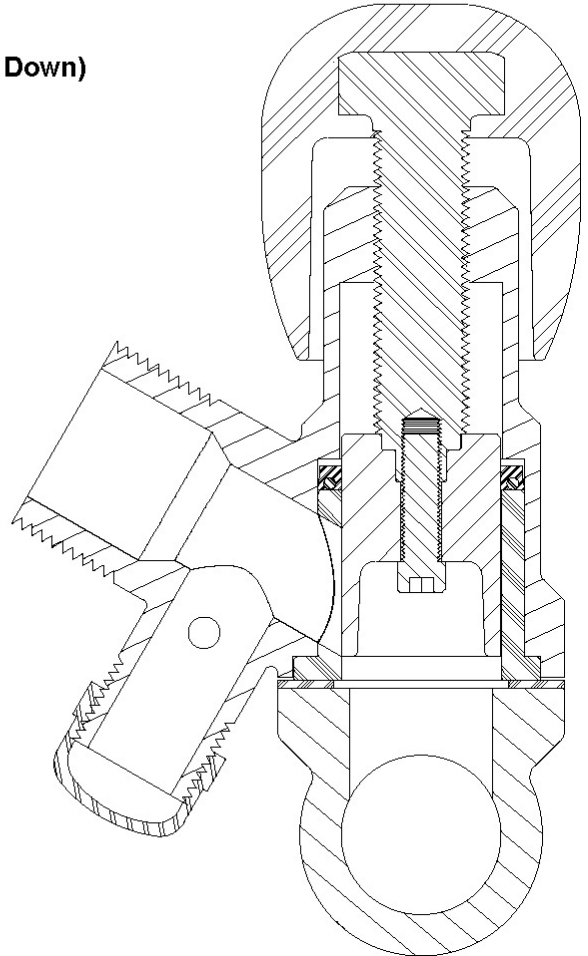

9.6 Combo Valve

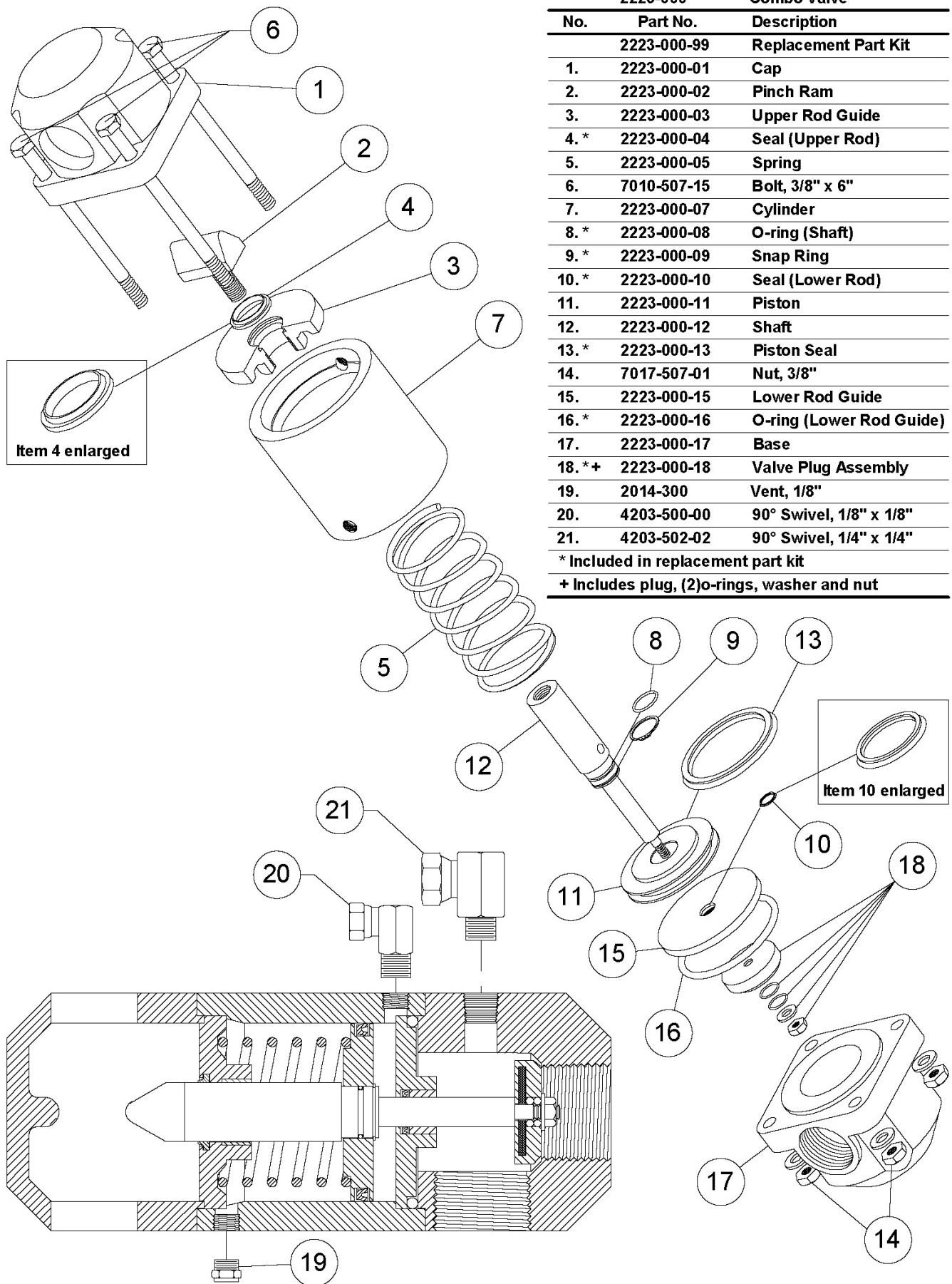

No.	Part No.	Description
	2223-000	Combo Valve
	2223-000-99	Replacement Part Kit
1.	2223-000-01	Cap
2.	2223-000-02	Pinch Ram
3.	2223-000-03	Upper Rod Guide
4.*	2223-000-04	Seal (Upper Rod)
5.	2223-000-05	Spring
6.	7010-507-15	Bolt, 3/8" x 6"
7.	2223-000-07	Cylinder
8.*	2223-000-08	O-ring (Shaft)
9.*	2223-000-09	Snap Ring
10.*	2223-000-10	Seal (Lower Rod)
11.	2223-000-11	Piston
12.	2223-000-12	Shaft
13.*	2223-000-13	Piston Seal
14.	7017-507-01	Nut, 3/8"
15.	2223-000-15	Lower Rod Guide
16.*	2223-000-16	O-ring (Lower Rod Guide)
17.	2223-000-17	Base
18.**	2223-000-18	Valve Plug Assembly
19.	2014-300	Vent, 1/8"
20.	4203-500-00	90° Swivel, 1/8" x 1/8"
21.	4203-502-02	90° Swivel, 1/4" x 1/4"

* Included in replacement part kit
 ** Includes plug, (2)o-rings, washer and nut

9.7 Control Valves (pneumatic and electric)

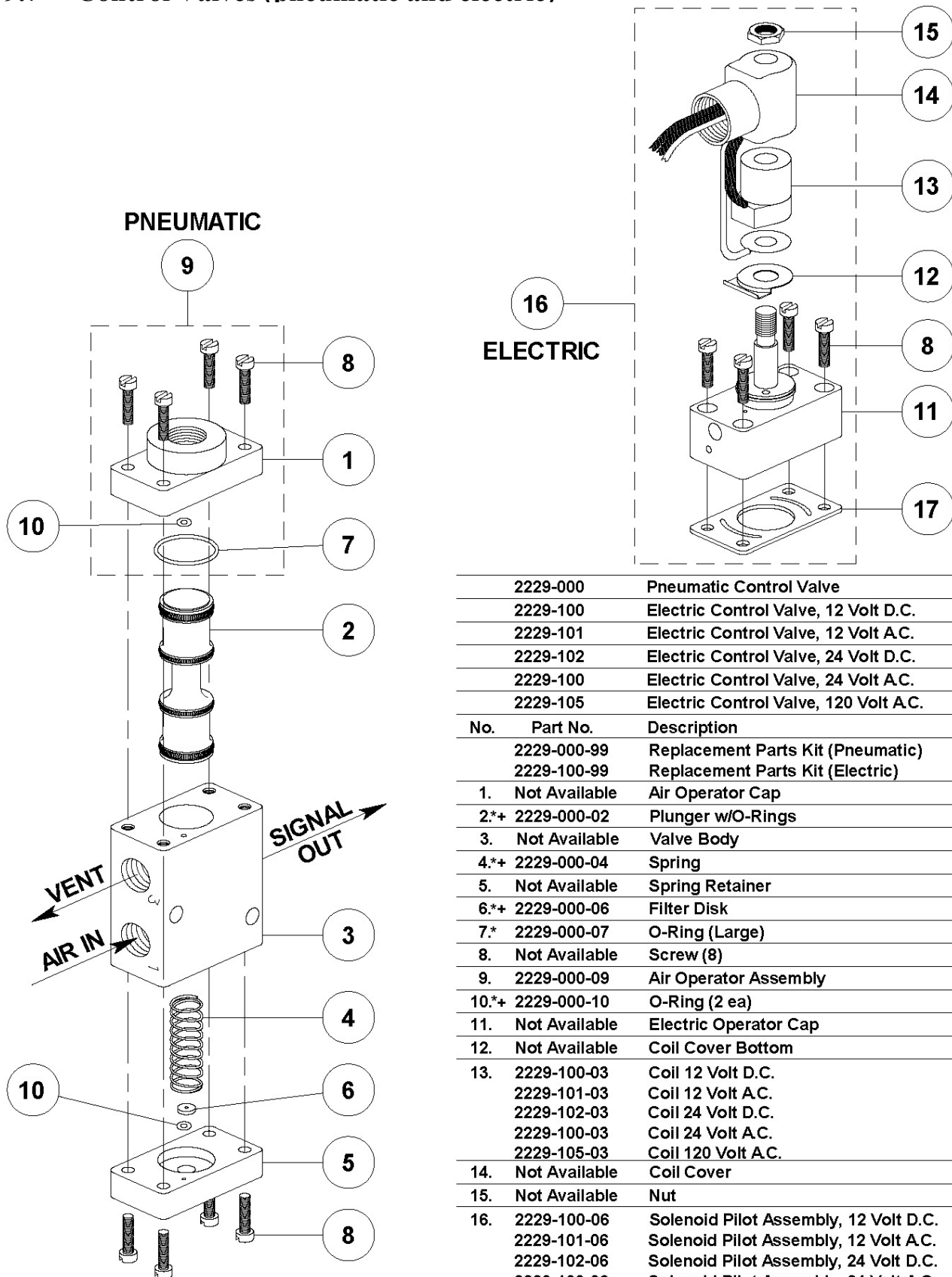

	2229-000	Pneumatic Control Valve
	2229-100	Electric Control Valve, 12 Volt D.C.
	2229-101	Electric Control Valve, 12 Volt A.C.
	2229-102	Electric Control Valve, 24 Volt D.C.
	2229-100	Electric Control Valve, 24 Volt A.C.
	2229-105	Electric Control Valve, 120 Volt A.C.
No.	Part No.	Description
	2229-000-99	Replacement Parts Kit (Pneumatic)
	2229-100-99	Replacement Parts Kit (Electric)
1.	Not Available	Air Operator Cap
2.*+	2229-000-02	Plunger w/O-Rings
3.	Not Available	Valve Body
4.*+	2229-000-04	Spring
5.	Not Available	Spring Retainer
6.*+	2229-000-06	Filter Disk
7.*	2229-000-07	O-Ring (Large)
8.	Not Available	Screw (8)
9.	2229-000-09	Air Operator Assembly
10.*+	2229-000-10	O-Ring (2 ea)
11.	Not Available	Electric Operator Cap
12.	Not Available	Coil Cover Bottom
13.	2229-100-03	Coil 12 Volt D.C.
	2229-101-03	Coil 12 Volt A.C.
	2229-102-03	Coil 24 Volt D.C.
	2229-100-03	Coil 24 Volt A.C.
	2229-105-03	Coil 120 Volt A.C.
14.	Not Available	Coil Cover
15.	Not Available	Nut
16.	2229-100-06	Solenoid Pilot Assembly, 12 Volt D.C.
	2229-101-06	Solenoid Pilot Assembly, 12 Volt A.C.
	2229-102-06	Solenoid Pilot Assembly, 24 Volt D.C.
	2229-100-06	Solenoid Pilot Assembly, 24 Volt A.C.
	2229-105-06	Solenoid Pilot Assembly, 120 Volt A.C.
17. +	2229-100-07	Gasket (Electric Only)
* Included In replacement parts kit-pneumatic		
+ Included In replacement parts kit-electric		

9.8(a) G2 Pneumatic Deadman

Item	Part No.	Description
	2263-002	G2 Pneumatic Deadman
	2263-002-99	G2 Replacement Parts Kit
1.	2263-002-01	G2 Deadman Lever
2.	2263-002-02	G2 Deadman Body
* 3.	2263-002-03	G2 Deadman Cartridge Assembly
4.	2263-002-04	G2 Deadman Hinge Pin
* 5.	2263-002-05	G2 Deadman Cartridge Set Screw
6.	2263-002-06	G2 Deadman Button
* 7.	2263-002-07	Deadman Spring
* 8.	2263-000-08	Deadman Screw For Button
9.	3031-300-00	Hex Nipple, 1/8" x 1/8" With Ball Seat
10.	3031-302-02	Hex Nipple, 1/4" x 1/4" With Ball Seat
* 11.	2263-002-10	G2 Deadman Dust Plug

* Items included in Replacement Kit

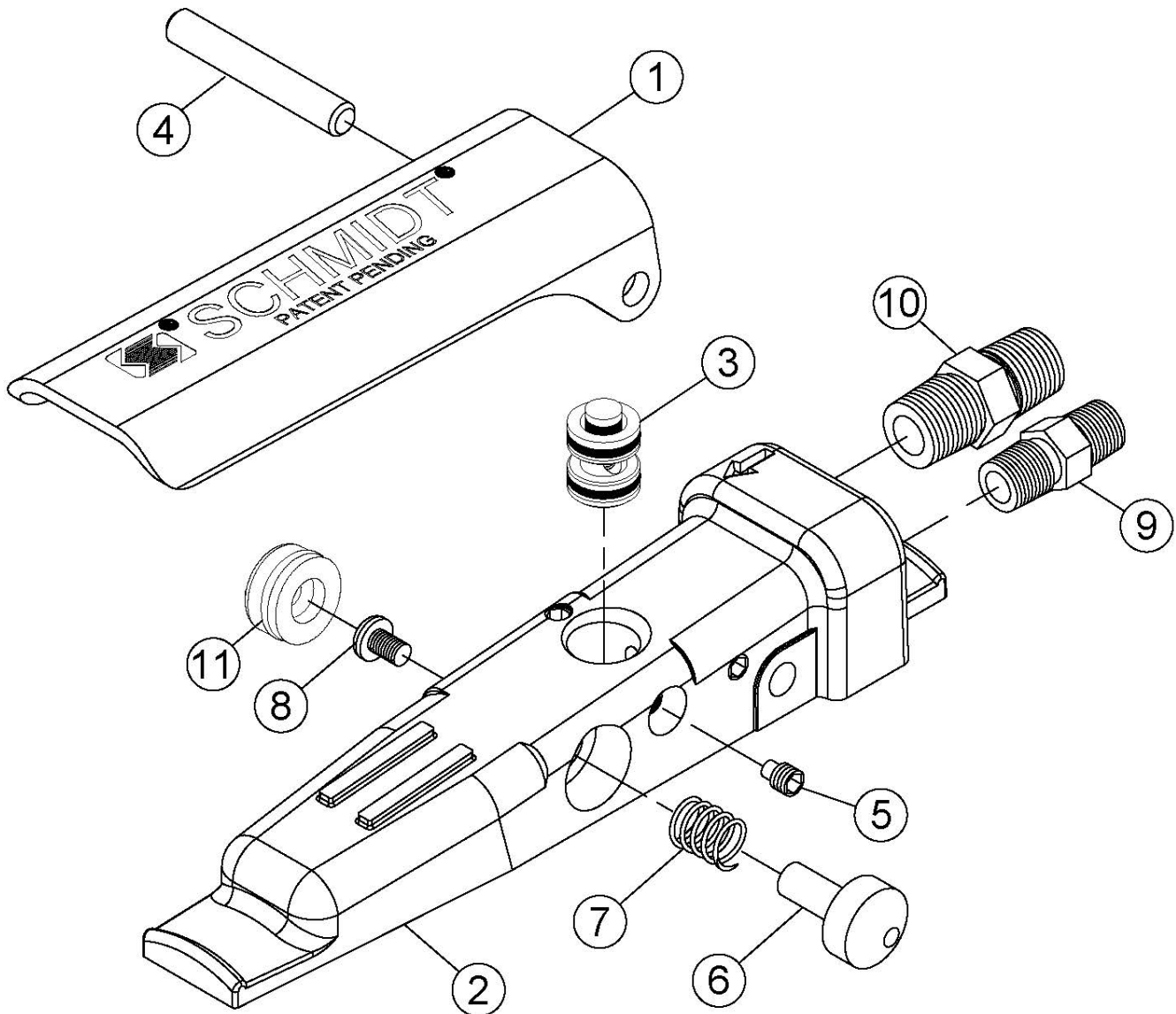

9.8(b) Deadman Valves (Pneumatic)

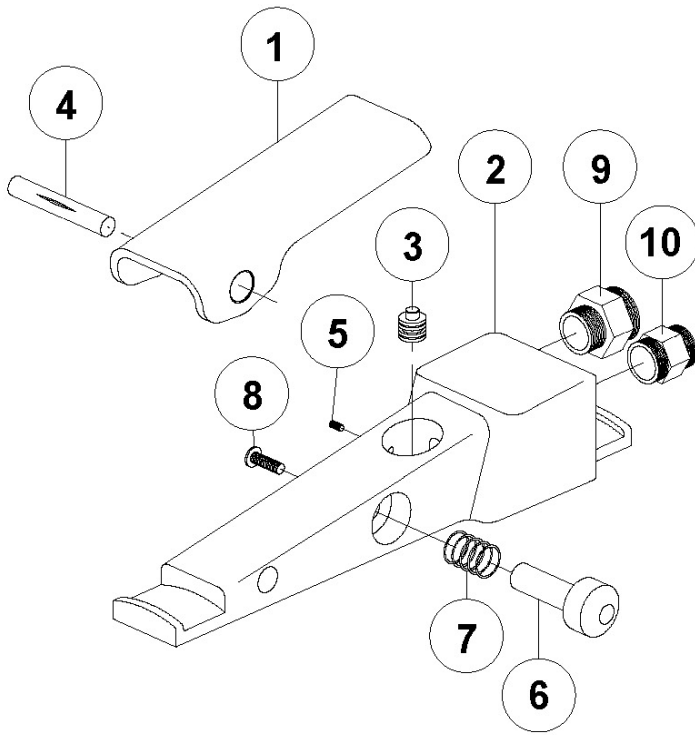

2263-000		Pneumatic Deadman
No.	Part No.	Description
2263-000-99 Replacement Parts Kit		
1.	2263-000-01	Lever
2.	2263-000-02	Body
*3.	2263-000-03	Cartridge
4.	2263-000-04	Hinge Pin
*5.	2263-000-05	Set Screw
6.	2263-000-06	Safety Button
*7.	2263-000-07	Spring
*8.	2263-000-08	Screw for Button
9.	3031-302-00	Hex Nipple, 1/8" x 1/4"
10.	3031-300-00	Hex Nipple, 1/8" x 1/8"
* Included in replacement parts kit		

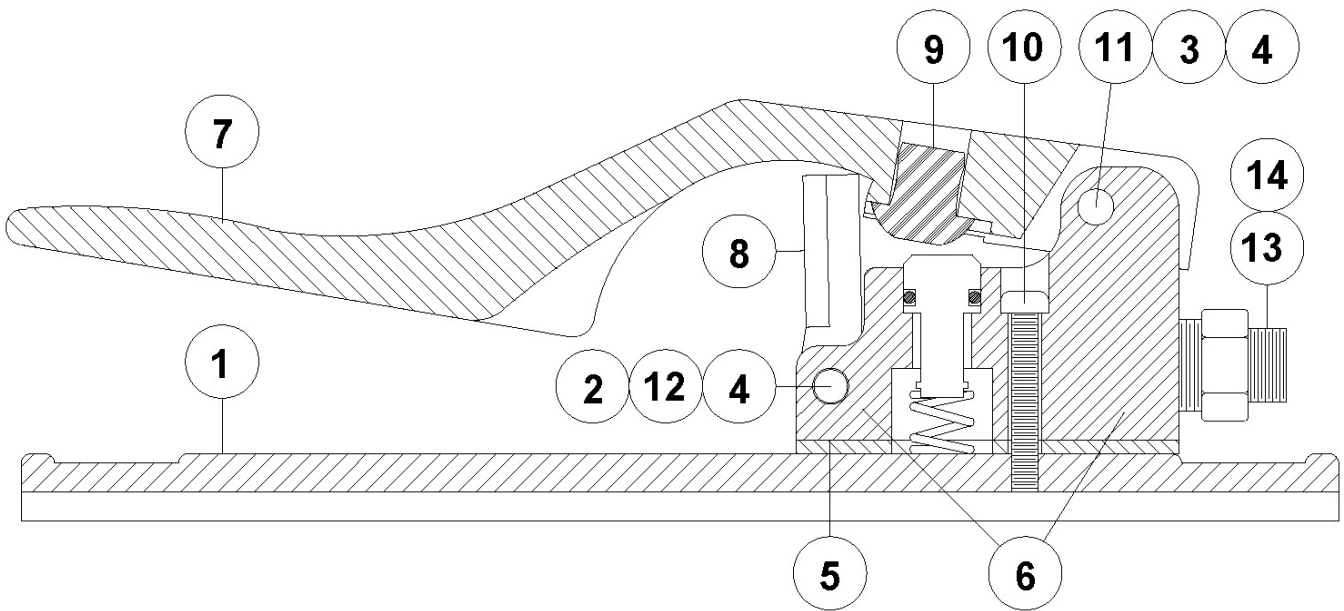

2263-001			Pneumatic Deadman II		
No.	Part No.	Description	No.	Part No.	Description
2263-001-99 Replacement Parts Kit Level I			2263-001-99 Replacement Parts Kit Level II		
1.	2263-001-01	Base	8. +	2263-001-08	Safety Flap
2. +	2263-001-02	Safety Flap Spring	9.**	2263-001-09	Plunger Plug
3. +	2263-001-03	Lever Hinge Screw	10.	2263-001-10	Body Mounting Screw
4.	2263-001-04	Hinge Pin Nut	11.	2263-001-11	Lever Spring
5.**	2263-001-05	Body Gasket	12. +	2263-001-12	Flap Hinge Screw
6.**	2263-001-06	Valve Body Assembly	13.	3031-302-00	Hex Nipple, 1/8" x 1/4"
7.	2263-001-07	Lever	14.	3031-300-00	Hex Nipple, 1/8" x 1/8"
			* Included in replacement parts kit, Level I		
			+ Included in replacement parts kit, Level II		

9.9 Deadman Switches (Electric)

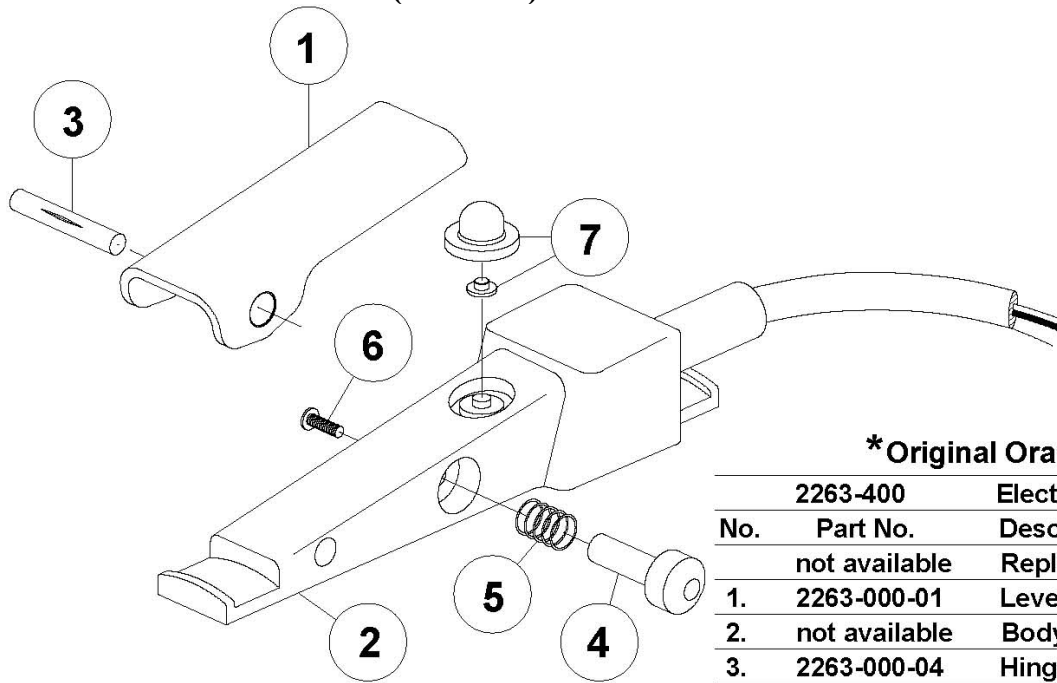

*Original Orange

No.	Part No.	Description
	2263-400	Electric Deadman
	not available	Replacement Parts Kit
1.	2263-000-01	Lever
2.	not available	Body w/Molded Switch
3.	2263-000-04	Hinge Pin
4.	2263-000-06	Safety Button
5.	2263-000-07	Spring
6.	2263-000-08	Screw for Button
7.	2263-400-09	Dust Cover w/Insert

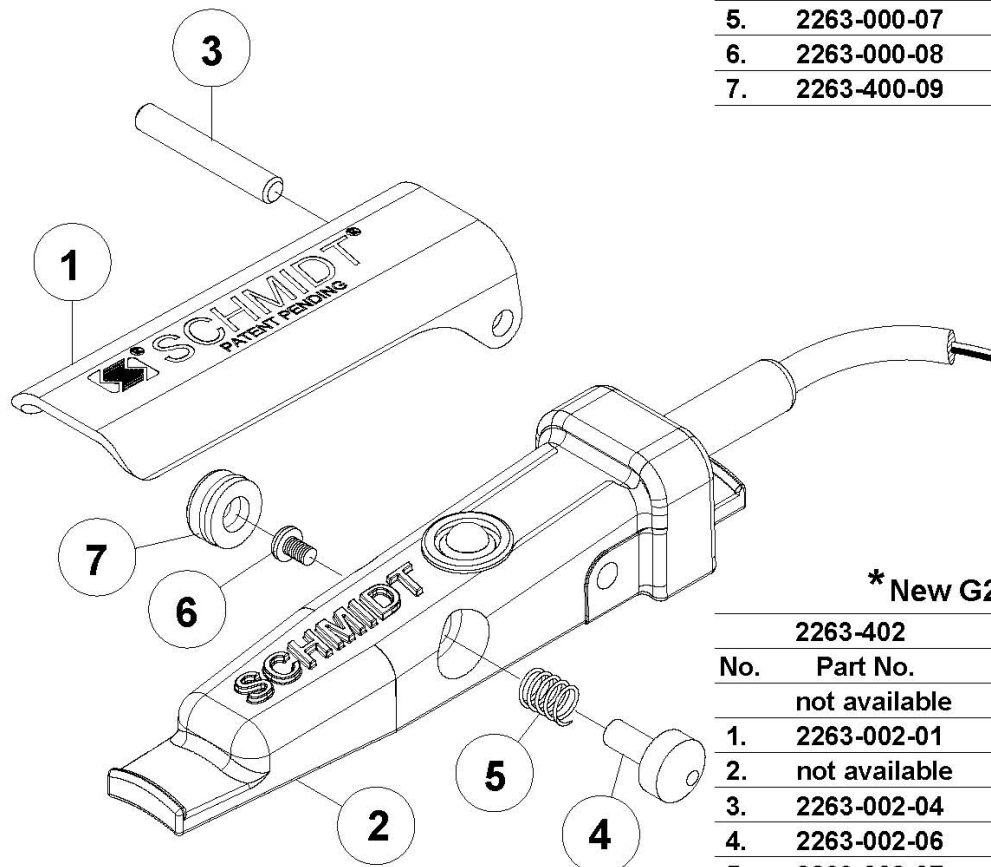

*New G2 Electric

No.	Part No.	Description
	2263-402	G2 Electric Deadman
	not available	Replacement Parts Kit
1.	2263-002-01	G2 Lever
2.	not available	G2 Body w/Switch
3.	2263-002-04	G2 Hinge Pin
4.	2263-002-06	G2 Safety Button
5.	2263-002-07	G2 Spring
6.	2263-000-08	Screw for Button
7.	2263-002-10	G2 Dust Plug

⚠ WARNING

*Electric shock hazard. To minimize shock hazard use electric deadman in low voltage applications only (12-24 volts).

THIS PAGE INTENTIONALLY BLANK

9.10 Volumetric Blowdown Suppression System*

No.	Part No.	Description
	2011-500-90	Volumetric Blowdown Suppression System
	2011-500-97	VBS Sounds Element Replacement Parts Kit
	2011-500-98	VBS Seal Gasket Replacement Parts Kit
	2011-500-99	VBS Complete Replacement Parts Kit
1.	2011-500-01	VBS Cap
2.	2011-500-02	VBS Base
3.	2011-500-03	VBS Casing
4.*	2011-500-04	VBS Internal Element
5.*	2011-500-05	VBS Cap Element
6.*	2011-500-06	VBS Deflector
7.*§	2011-500-07	VBS Casing Gasket
8.*§	2011-500-08	VBS Internal Gasket
9.	2011-500-29	VBS Restrictor #12 1 1/4" x 3"
10.	2011-500-09	VBS Arbasive Exhaust Cap
11.	2011-500-10	VBS Stud 5/16"-18 x 14" Lg.
12.	7017-505	Hex Nut, 5/16" UNC
13.*	2011-500-12	VBS Exhaust Sound Element Disc
14.*	2011-500-13	VBS Exhaust Sound Element
15.	7024-501-07	Screw #10-16, 3/8"
16.	7024-501-05	Screw #10-16, 3/4"

+ Included In Replacement Parts Kit For Sound Element replacements
 § Included In Replacement Parts Kit For Seal Gasket replacements
 * Included In Replacement Parts Kit For Complete replacements

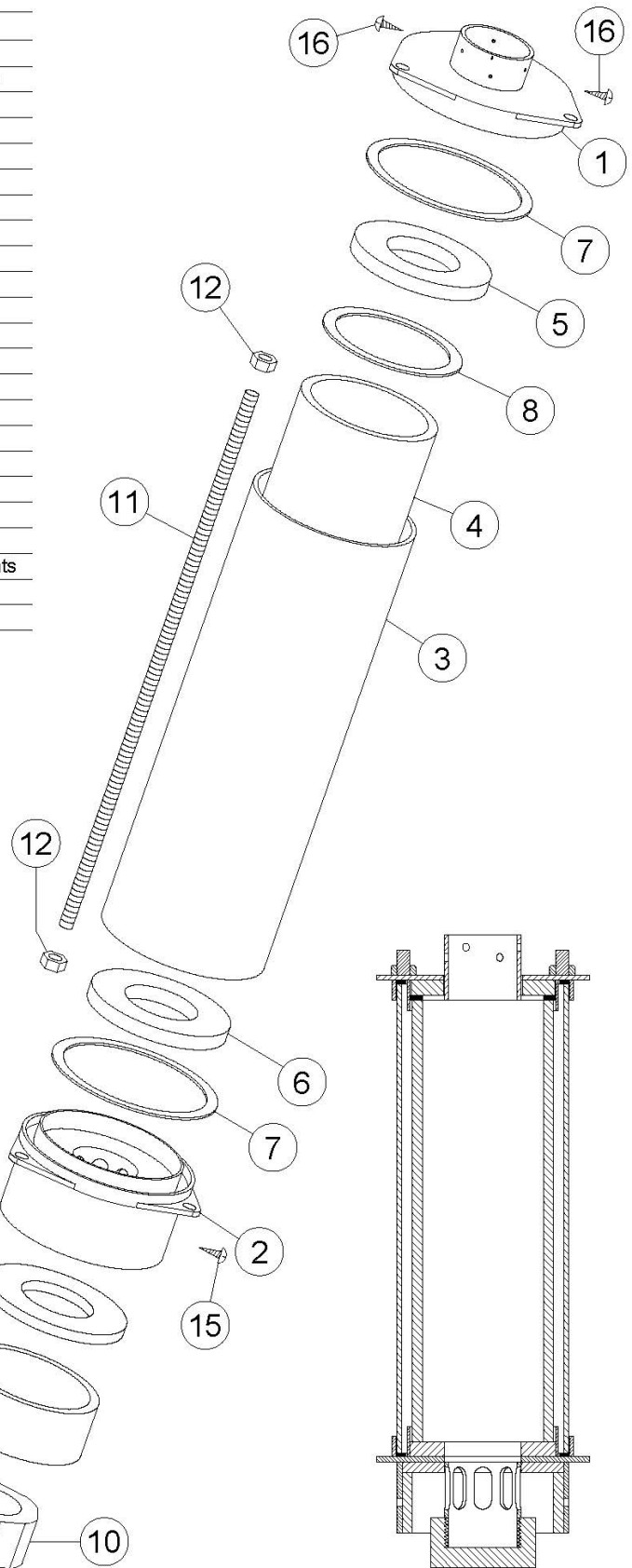
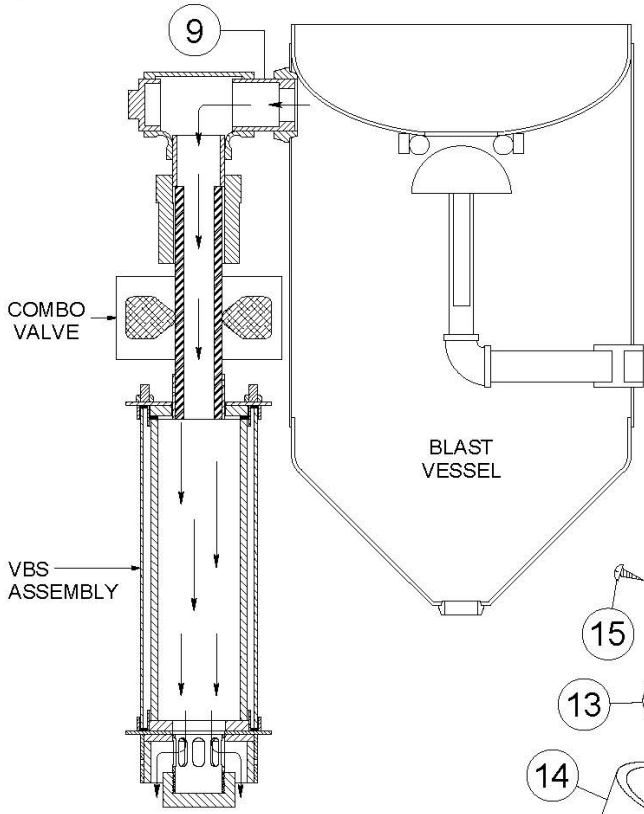

* Patent Pending

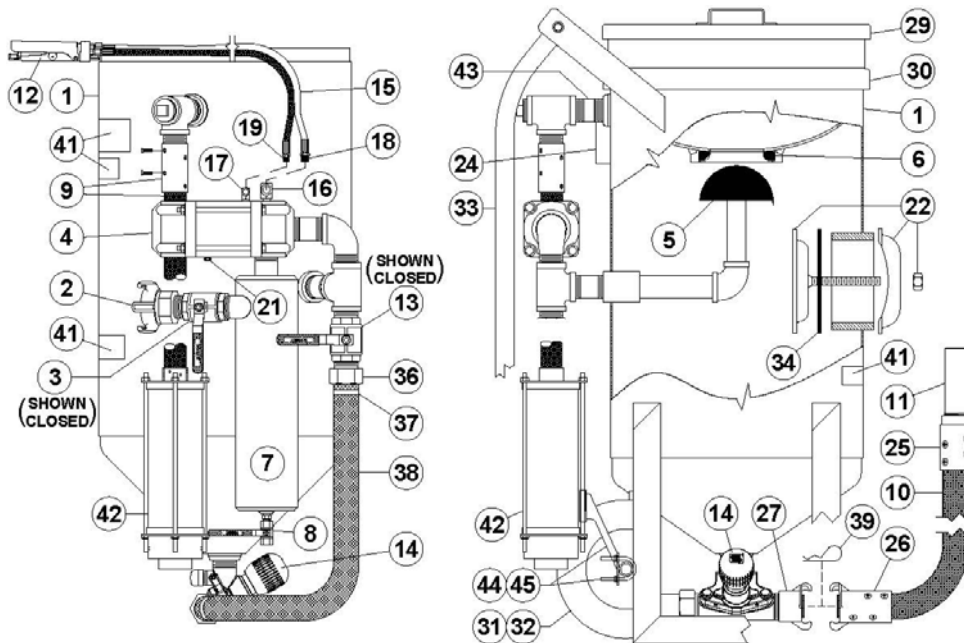

Figure 9.10.1 Typical MV2 Blaster with the VBS System

GENERAL INFORMATION

The Volumetric Blowdown Suppression (VBS) System (#42) is designed to reduce the noise level and eliminate floor damage caused by the Combo Valve® blowdown exhaust air. The VBS attaches to the end of blowdown hose assembly (#9) and is supported by a bracket (#44) with U-bolt. The VBS System changes the characteristics of the blowdown exhaust air as it flows through. First, the VBS reduces the noise level of the blowdown air by internal sound absorption. Secondly, the VBS system diffuses and reduces the velocity of the blowdown air and abrasive mixture. The VBS self-cleaning urethane exhaust cap design absorbs the abrasive impact to reduce wear on the internal components and prevents clogging.

The standard blowdown hose must be shortened to 14-1/2” to accommodate the VBS System.

Note: The VBS is standard on MV2 / Combo Valve package blasters manufactured after June 2011. Conversion kits are available for field addition of the VBS System. Consult Axxiom Manufacturing, Inc. or an authorized Schmidt distributor.

⚠ WARNING

Airborne particles and loud noise hazards from blowdown exhaust air can cause serious injury and loss of hearing. Wear approved eye and ear protection. Stay clear of exhaust air path. **DO NOT** place hands or other body parts in the exhaust air path. Make sure no personnel are in the exhaust air path.

MAINTENANCE AND INSPECTION

The VBS should be disassembled and inspected monthly, or more frequently for heavy usage. Check the blowdown hose assembly weekly for wear and other damage. Replace parts as needed with Schmidt® original factory replacement parts furnished by an authorized Schmidt distributor.

⚠ DANGER

Depressurize vessel before performing any maintenance. Removing the VBS with the abrasive blaster pressurized could result in serious injury or death.

⚠ DANGER

Do Not obstruct the VBS base air flow. Obstructing the VBS flow can cause component failure and result in serious injury or death.

⚠ WARNING

Worn or damaged blowdown hose may cause VBS to detach from the hose assembly and can result in injury to personnel.

10.0 Recommended Spare Replacement Parts Lists

MV2 Valve Abrasive Blaster Spare Replacement Parts List

A) ELECTRIC and PNEUMATIC CONTROLS (see note below & refer to Section 9.0 drawings)

Item No.	Qty.	Part No.	Description
2	1	42XX-10X	Air Inlet Crowfoot (specify piping size)
2	10	42XX-999	Crowfoot Gasket (specify piping size)
3	1	2401-50X	Air Inlet Ball Valve (specify piping size)
4	1	2223-000	Combo Valve
4	2	2223-000-99	Repair Kit, Combo Valve
5	1	2100-010	Popup With Stem
6	1	2100-011	Popup Gasket
8	1	2401-502	Drain ball valve, 1/4"
9	1	4115-005-XX	Blowdown hose assembly (specify vessel size)
10	1	4104-40X-XX	Blast hose assembly (specify size and length)
11	1	500X-XXX	Blast nozzle (specify size and type)
13	1	2401-50X	Choke Ball Valve (specify piping size)
14	1	2127-10X	MV2 Valve (specify piping size)
14	1	2127-100-98	MV2 Valve replacement parts seals kit
14	1	2127-100-99	MV2 Valve replacement parts kit
14	1	2127-00X-10	MV2 Valve Base, (specify piping size)
21	1	2014-300	Breather vent, 1/8"
22	1	7000-001-11	Handway crab assembly, 6" x 8"
25	2	4215-XXX	Nozzle Holder (specify size and type)
26	2	4213-XXX	Blast Hose Coupling (specify size)
27	2	4214-XXX-01	Threaded coupling (specify size and type)
27	20	4214-999	Coupling Gasket (fits hose and threaded couplings)
34	2	7000-001-06	Handway Gasket, 6" x 8"
36	2	4205-10X	Hose insert (specify size)
36	10	4205-10X-99	Insert gasket
37	2	4235-00X	Hose clamp, double bolt (for field installation) (specify size)
38	10ft	4102-00X	Air hose (specify size)
39	20	7119-002	Safety Pin, Air/Blast Hose Coupling
40	2	8710-98778	Hose whip check
41	1	7031-999-02	Safety decal kit (See Section 0.0)
-	1	2408-907	Union end ball valve (optional) See Section 5.13

B) ITEMS FOR PNEUMATIC CONTROLS ONLY (see note below)

Item No.	Qty.	Part No.	Description
12	1	2263-XXX	Pneumatic Deadman Valve (specify type)
12	2	2263-XXX-99	Pneumatic Deadman Valve Replacement Parts Kit (specify type)
15	1	4100-501	Twinline Hose, 55ft.

C) ITEMS FOR ELECTRIC CONTROLS ONLY (see note below)

12	1	2263-402-01	G2E Electric Deadman Switch With Plug
15	1	7074-055	Extension Cord 55'
16,19	1	7109-300	Female Twist-lock Connector, 3-Prong
17,18	1	7109-301	Male Twist-lock Plug, 3-Prong
20	1	2229-100	Electric Control Valve, 12Vdc
20	2	2229-100-99	Electric Control Valve Replacement Parts Kit
20	1	7112-000	Power tee, 12Vdc with coil and connectors
35	1	2013-402	Dust Eliminator, 1/4"

NOTE: Determine the type of blast controls on the abrasive blaster (either electric or pneumatic). Then, the required list of spare parts is List "A" plus either List "B" or "C". Example: If your abrasive blaster has pneumatic controls then the recommended spare parts you need are those items included in Lists "A" and "B". For blasters with special options refer to supplemental drawing(s) included with this operation an maintenance manual.

11.0 Troubleshooting

This section lists probable causes of problems that may occur during operation of the abrasive blaster. Not all of the “probable causes” may apply to your particular abrasive blaster. The probable cause may not apply because of the control type and accessories on the abrasive blaster. Refer to Figure 11.1 and the drawings in Section 9.0.

DANGER

The MV2 Valve abrasive blaster is a Pressurized Vessel. Propelled objects will cause serious injury or death. Depressurize vessel before performing any maintenance. See Section 6.2.

11.1 Malfunction With Deadman Lever In The “Off” Position

11.1.1. Abrasive stops but blast air will not shut off

- (1) Defective or broken valve plug assembly in Combo Valve (#4).
- (2) Defective Combo Valve (#4) lower rod guide seal.

11.1.2. Both blast air and abrasive will not shut off

- (1) Twinline hoses to deadman valve (#12) are crossed.
- (2) Non-Schmidt deadman (#12) has been installed.
- (3) Control valve (#20) stuck in the “ON” position. (MV2 Electric only)
- (4) Blocked twinline hose.
- (5) Defective deadman valve (#12). Pneumatic deadman cartridge plunger stuck in the “ON” position (down). Cartridge plunger is visible below deadman handle.
- (6) Defective or broken Combo Valve (#4) spring.
- (7) Defective Combo Valve (#4) lower rod guide seal.

11.1.3. Blast outlet turns on accidentally

- (1) The deadman lever (#12) is worn out.
- (2) The safety button on the deadman is missing. See drawings in Sections 9.8 and 9.9.
- (3) A bleeder type deadman valve has been installed. A bleeder type deadman valve *is not safe* because a particle of dirt from the air hose can plug the bleed hole and cause the blast outlet to turn on. See *Warnings* and *Rules for Safer Operation* in Section 1.0.
- (4) Defective electric deadman switch or electric wiring (check for an electric short).
- (5) Defective Combo Valve (#4) lower rod guide seal.

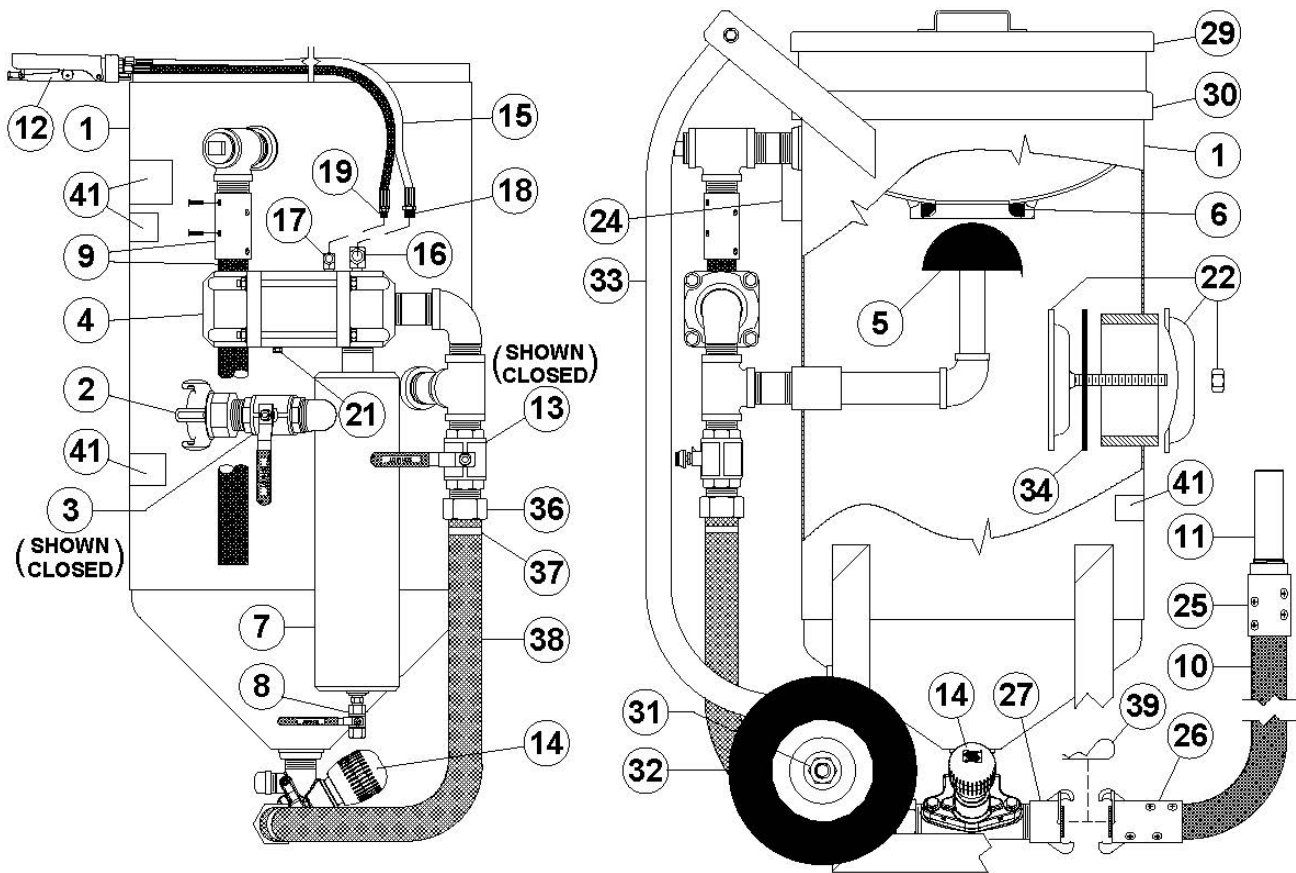

Figure 11.1 – MV2 Valve Abrasive Blaster with pneumatic blast controls

11.2 Malfunction With Deadman Lever In The “On” Position

11.2.1. Air blasts with no abrasive

- (1) Check abrasive level in blast vessel.
- (2) MV2 Valve (#14) plunger stuck in closed position.
- (3) Trash plugging opening from tank to MV2 Valve (#14). See Section 11.3.
- (4) Abrasive flow problems. See Section 11.3.
- (5) Blast vessel leak (popup or handway) reduces pressure slowing abrasive flow.

11.2.2. Abrasive choking out of blast hose with low blast air pressure

- (1) MV2 Valve (#14) abrasive adjustment knob is open too far.
- (2) Choke valve (#13) is partially closed causes differential pressure increases abrasive flow.
- (3) Low air compressor output cfm (unit may cycle on and off). See Section 3.0.

11.2.3. Reduced Pressure At The Nozzle (with or without abrasive flow)

- (1) Low air compressor output CFM. See Section 3.0 to determine air requirements.
- (2) Air supply hose to blaster is too small. See Section 3.0.
- (3) MV2 Valve abrasive adjustment knob (#14) is open too far.
- (4) Check for leaks in blast vessel (popup or handway) or control piping.
- (5) Choke valve (#13) is partially closed.
- (6) Trash may be partially plugging the nozzle orifice (#11).

11.2.4. Blast is slow to turn on or will not turn on when deadman lever is pressed down.

- (1) Check twinline hose connections (#18 & #19) to see if they are connected properly.
- (2) Electric deadman control valve (#20) stuck in exhaust position (air leaks from breather #35).
- (3) 1/4" strainer (#23) blocked; restricts air flow to deadman (MV2 electric only).
- (4) Twinline control hoses (#15) are blocked.
- (5) Cartridge in deadman valve (#12) is blocked.
- (6) Low air compressor output CFM (unit may cycle on and off). See Section 3.0.
- (7) Air leaks in twinline hose (#15) from the deadman valve (#12).
- (8) Trash blocking the blast nozzle orifice (#11).

11.3 Notes on Abrasive Flow Problems

11.3.1. Contaminated Abrasive

Air quality is crucial to the operation of an abrasive blaster. Moisture and contaminants can cause components to malfunction. Moisture condensation in a blast system causes abrasive flow problems. Condensation occurs when the hot vapor-filled compressed air cools as it reaches the abrasive blaster. Water droplets formed during condensation can be absorbed by the abrasive in the blast vessel which can cause erratic flow to the abrasive valve. Therefore, a moisture removal device installed for the blast system air supply is recommended (i.e. coalescing moisture separator, air-cooled aftercooler or deliquescent dryer). Contact a local authorized Schmidt® distributor or Axxiom Manufacturing, Inc. to locate one near you.



Do Not hammer on any part of the pressure vessel to improve abrasive flow. This can cause cracks that may lead to pressure vessel rupture.

11.3.2. Choking the blast outlet

The choke valve (#13) is used to clear any trash that may get into the blast vessel and block the MV2 Valve orifice. Whenever trash (paint chip, cigarette butt, etc.) blocks the abrasive valve orifice, the procedure is to fully open the valve by turning the knob counterclockwise, then press down the deadman lever (#12) to begin blasting. While blasting, have an assistant close the choke valve completely for about one second. This creates differential pressure at the abrasive valve (high pressure above; low pressure below). The higher pressure from the blast vessel should be enough to loosen the trash blocking the abrasive valve orifice and blast it through the blast nozzle (#11). To minimize excess wear of the MV2 Valve keep the choke valve fully open during normal blasting.

Note: The MV2 Valve includes a cleanout port to use for this procedure. See the valve drawings in Section 9.5 (Item 14).

11.3.3. Blast control hoses

Remember, the blaster controls and valves are normally closed. Therefore, the control hoses are depressurized to turn the blast off and pressurized to turn the blast on. If a needle gauge is available, it is the quickest way to check to see if there is pressure in the control hoses. If no needle gauge is available, disconnect each control hose fitting one at a time until the problem is located.

12.0 Warranty and Reference Information

12.1 Warranty

This following section is to be used as a guide in determining warranty policies and procedures for SCHMIDT® products. It is to be used in determining whether a warranty is justified and as a procedural guide in completing a SCHMIDT warranty claim.

12.2 Warranty Policy

1. All SCHMIDT products are guaranteed to be free of defects in material and workmanship at time of shipment. Axxiom Manufacturing, Inc. warrants its products against defects in material and workmanship under normal and proper use for a period of ninety (90) days from the date of delivery. Such warranty is extended only to the buyer who purchases the equipment directly from Axxiom Manufacturing, Inc. or its authorized distributors. This warranty does not include expendable parts such as, but not limited to, hoses, nozzles, and seals.
2. The obligation under this warranty is strictly limited to the replacement or repair, at Axxiom's option, of machines and does not include the cost of transportation, loss of operating time, or normal maintenance services. Axxiom Manufacturing, Inc. shall have no liability for labor, consequential damages, freight or special charges.
3. This warranty does not apply to failure occurring due to abuse, misuse, negligence, corrosion, erosion, normal wear and tear, alterations or modifications made to the machine without express written consent of Axxiom Manufacturing, Inc.
4. Warranty requests must be submitted in writing within thirty (30) days after failure.
5. Written authorization to return merchandise under warranty must first be obtained from Axxiom Manufacturing, Inc. In no case is merchandise to be returned to Axxiom for credit without authorization. At the time of authorization, Axxiom will issue a return authorization number that must be included on all packages and correspondence. Any material returned without prior authorization will remain the property of the sender and Axxiom will not be responsible for it.
6. All returns must be shipped prepaid freight. All returns may be exchanged for other equipment or parts of equal dollar value. If goods are not exchanged, they are subject to a 20% restocking charge. Any cost incurred by Axxiom Manufacturing, Inc. to restore such goods to first class condition will be charged to the customer.
7. Axxiom Manufacturing, Inc. reserves the right to inspect and make the final decision on any merchandise returned under warranty.
8. Axxiom Manufacturing, Inc. offers no warranty with respect to accessories, including but not limited to, engines, motors, batteries, tires and any other parts not manufactured by Axxiom Manufacturing, Inc., but which the original manufacturer warrants.

9. Axxiom Manufacturing, Inc. reserves the right to make product changes or improvements without prior notice and without imposing any obligation upon itself to install the same on its products previously sold.
10. The above warranty conditions can only be altered by Axxiom Manufacturing, Inc. Axxiom must confirm alterations in writing for each specific transaction.
11. Axxiom Manufacturing, Inc. reserves the right to establish specific warranty terms for used or demo machines on an individual transaction basis. Invoices covering such merchandise will clearly state the provisions of the applicable warranty for each specific transaction.
12. USE OF NON-ORIGINAL SCHMIDT® FACTORY REPLACEMENT PARTS ON ANY SCHMIDT EQUIPMENT VOIDS ALL WARRANTIES.
13. AXXIOM MANUFACTURING, INC. DOES NOT AUTHORIZE ANY PERSON, REPRESENTATIVE OR SERVICE OR SALES ORGANIZATION TO MAKE ANY OTHER WARRANTY OR TO ASSUME ON BEHALF OF AXXIOM MANUFACTURING, INC. ANY LIABILITY IN CONNECTION WITH THE SALE OF OUR PRODUCTS OTHER THAN THOSE CONTAINED HEREIN.
14. UNDER NO CIRCUMSTANCES SHALL AXXIOM MANUFACTURING, INC. BE LIABLE TO CUSTOMER OR ANY OTHER PERSON FOR ANY DIRECT, INCIDENTAL, OR CONSEQUENTIAL DAMAGES RESULTING FROM THE USE OF THE PRODUCT OR ARISING OUT OF ANY BREACH OF ANY WARRANTY OR FOR ANY SPECIAL OR CONSEQUENTIAL DAMAGES OF ANY CHARACTER, INCLUDING WITHOUT LIMITATIONS, DAMAGES FOR ANY LOSS OF GOODWILL, WORK STOPPAGE, OR ANY AND ALL OTHER COMMERCIAL DAMAGES OR LOSSES.
15. AXXIOM MANUFACTURING, INC. MAKES NO OTHER WARRANTIES, EXPRESSED OR IMPLIED, INCLUDING, BUT NOT LIMITED TO, THE IMPLIED WARRANTIES OF MERCHANTABILITY AND FITNESS FOR A PARTICULAR PURPOSE WITH RESPECT TO THE SCHMIDT PRODUCTS SOLD PURSUANT THERETO.

12.3 Trademarks, Patents, and Proprietary Statements

Schmidt, the Schmidt S logo, Thompson Valve, and Combo Valve are registered trademarks owned by Axxiom Manufacturing, Inc. Use of the Schmidt, the Schmidt S logo, Thompson Valve, and Combo Valve trademarks without the written consent of Axxiom Manufacturing is strictly prohibited.

Products manufactured and marketed by Axxiom Manufacturing, Inc. are protected by patents issued or pending in the United States and other countries.

The text, diagrams, and drawings contained in this manual are proprietary information intended solely for instruction in the operation of the specified equipment. Use of any text, diagrams, or drawings contained in this manual for any reason other than its intended purpose without the written consent of Axxiom Manufacturing, Inc. is strictly prohibited.

12.4 Safety Information Sources

Axxiom Manufacturing, Inc

This equipment and all Schmidt® equipment are manufactured exclusively by Axxiom Manufacturing, Inc. If any operational or safety related questions arise relating to this equipment contact Axxiom Manufacturing, Inc.

Phone: 1-800-231-2085

Website: www.SchmidtAbrasiveBlasting.com

Axxiom Manufacturing, Inc.

11927 South Highway 6

Fresno, Texas 77459

Occupational Safety and Health Administration (OSHA) establishes and enforces regulations regarding safety practices in the workplace including the abrasive blasting industry. Any questions, reporting of work related injuries, or reporting of unsafe work practices can be made to the following contact information. Answers to most any safety related questions can be found at the OSHA website shown below.

Phone: 1-800-321-6742

Website: www.osha.gov

U.S. Department of Labor

Occupational Safety and Health Administration

200 Constitution Avenue

Washington D.C. 20210

National Institute of Occupational Safety and Health (NIOSH) is a federal agency responsible for conducting research and recommendations for the prevention of work related injuries and sickness.

Phone: 1-800-356-4674

Website: www.cdc.gov/niosh

National Institute of Occupational Safety and Health

Hubert H. Humphrey Bldg.

200 Independence Avenue, SW

Room 715H

Washington, DC 20201

American National Standards Institute (ANSI) coordinates the development and use of voluntary consensus standards including safety standards.

Phone: 1-202-293-8020

Website: www.ansi.org

American National Standards Institute

1819 L Street, NW

6th Floor

Washington, DC 20036

12.5 Surface Preparation Information Sources

The Society for Protective Coatings (SSPC) consists of research and testing committees, conducts seminars and establishes industry standards on surface preparation methods, abrasive and coatings.

Phone: 1-412-281-2331

Website: www.sspc.org

The Society for Protective Coatings
40 24th Street
Pittsburg, PA 15222-4643

National Association of Corrosion Engineers (NACE) develops test methods and recommended practices on surface preparation techniques and coatings.

Phone: 1-281-228-6200

Website: www.nace.org

National Association of Corrosion Engineers
1440 South Creek Drive
Houston, TX 77084

12.6 Table of Blast Abrasive Characteristics

Abrasive Type	Hardness (Mohs)	Grain Shape	Density Lbs/ft ³	Color	Free Silica Content	No. of Recycles	Initial Cost	Typical Use
Corn Cobs	2	angular	35-45	tan	none	4-5	low	stripping paint from delicate substrates
Sodium Bicarbonate	2.8	crystal	60	white	none	4-5	medium	cleaning and stripping paint from delicate substrates
Walnut Shell	3	angular	45	lt. brown	none	4.5	low	stripping paint from delicate substrates
Plastic	3.2	angular	45-60	white	none	8-10	medium	Paint stripping, deburring, and cleaning
Glass Beads	4.5	spherical	90	crystal	none	8-10	low	cleaning finishing
Starblast XL	6.5	spherical	128	lt. brown	<1%	4-5	medium	outdoor blasting
Coal Slag	7	angular	85	black	none	1-2	medium	outdoor blasting
Copper Slag	7	angular	112	black	none	1-2	medium	outdoor blasting
Garnet	7	angular	147	pink	<2%	4-5	medium	outdoor blasting
Steel Shot	8	spherical	280	steel grey	none	200	low	cleaning and peening
Steel Grit	8	angular	280	steel grey	none	200	medium	removing heavy scale
Aluminum Oxide	9	angular	120	brown	<1%	6-8	medium	cleaning and finishing, deburring and etching

13.0 Blasting Data

13.1 Table 1 Approximate Air Consumption (CFM) Per Blast Nozzle

NOZZLE SIZE	NOZZLE PRESSURE						
	60 psi	70 psi	80 psi	90 psi	100 psi	120 psi	140 psi
No.2 1/8"	14	16	18	20	22	26	30
No.3 3/16"	32	36	41	45	49	58	66
No.4 1/4"	57	65	72	80	90	105	121
No.5 5/16"	90	101	113	125	140	160	185
No.6 3/8"	126	145	163	182	200	235	270
No.7 7/16"	170	193	215	240	270	315	360
No.8 1/2"	230	260	290	320	350	410	470
No.10 5/8"	360	406	454	500	550	640	740
No.12 3/4"	518	585	652	720	790	925	1060

13.2 Table 2 Abrasive Consumption (lbs. per hour) Per Blast Nozzle

NOZZLE SIZE	NOZZLE PRESSURE						
	60 psi	70 psi	80 psi	90 psi	100 psi	120 psi	140 psi
No.2 1/8"	90	105	115	130	140	165	190
No.3 3/16"	205	230	260	290	320	375	430
No.4 1/4"	365	420	460	500	560	660	760
No.5 5/16"	575	650	725	825	900	1050	1200
No.6 3/8"	840	945	1050	1155	1260	1475	1700
No.7 7/16"	1150	1300	1450	1600	1750	2050	2350
No.8 1/2"	1460	1660	1850	2000	2250	2650	3000
No.10 5/8"	2290	2600	2900	3125	3520	4100	4750
No.12 3/4"	3300	3750	4180	4500	5060	5950	6800

13.3 Table 3 Hose Selection Guide (blasting @ 100 Psi)

NOZZLE SIZE	No.4 1/4"	No.5 5/16"	No.6 3/8"	No.7 7/16"	No.8 1/2"
CFM @ 100psi	90	140	200	270	350
AIR HOSE	1 1/4"	1 1/4"	1 1/2"	1 1/2"	2"
BLAST HOSE	1"	1 1/4"	1 1/4"	1 1/2"	1 1/2"
ABRASIVE (lbs per hr)	560	900	1260	1750	2250

13.4 Additional Information on Blasting Productivity

Air volume and pressure are very important. The blasting production rate will increase with higher blasting pressures and decrease with lower blasting pressures. The National Association of Corrosion Engineers' data suggests that for each 1 psi reduction in nozzle pressure, there is a 1.5% production loss. Pressure drop through a Schmidt® blast unit is normally less than 1 psi, while blast units manufactured by some of our competitors have pressure losses as high as 12 psi resulting in an 18% loss of production. Air pressure loss can also be avoided by using the shortest possible hose of adequate size. The inside diameter of both the blast hose (other than whip hose) and the air hose should be approximately three times the diameter of the orifice in the blast nozzle.

Standard Schmidt blast units are rated for a maximum pressure of 125 psi or 150 psi. Refer to the pressure vessel nameplate for maximum operating pressure.