

CLEMCO[®]

*Contractor
Series*

*Abrasive Blast
Machines*



CLEMCO
Abrasive Blast Cleaning Equipment
Rated 150^{PSI}
Working Pressure



WARNING
Read and understand the instructions and safety warnings on the operator's manual before using this equipment. Failure to do so may result in injury or death. This equipment is not to be used for purposes other than those intended. Always use proper safety practices when operating this equipment. For more information, contact your distributor or visit our website at www.clemco.com.

Durability — Designed to Last, Built to Last

Clemco manufactures your Contractor Blast Machine to stand up to years of field use.

The ASME-certified welders at Clemco's plant in Washington, MO have an average of 10 years experience. Using computer-controlled equipment, these craftsmen lay down smooth, continuous welds along every seam, so the pressure vessel is durable and leak-proof.



The plate steel walls and the spun steel cone and head meet ASME standards.



Contractor Blast Machine

Exclusively from Clemco Industries Corp.

Your Contractor Blast Machine comes mounted on an ergonomic cart made from heavy-duty steel tubing. This built-in cart makes it easy to move your blast machine — both at the blast site and onto or off your pickup or trailer.

The cart's handles form a cage that protects the components most likely to be damaged — remote control valves, piping, CPF breathing air filter.

On four-cubic-foot and six-cubic-foot models, large rear tires and smaller front tires make moving your Contractor Blast Machine a breeze. The free wheeling tires roll easily over minor surface irregularities and the cart safely supports the weight to eliminate the strain on your back.

On the lighter two-cubic-foot model, two wheels are provided.



Machine Systems

All Contractor Blast Machines are rated for 150 psi working pressure — meeting the demands of high productivity of commercial and industrial jobs.

Your Contractor Blast Machine is ASME-certified, which is your assurance that the pressure vessel will stand up to years of high-production blasting.



The steel handles double as skids to allow you to pull the blast machine into the truck bed and leave it horizontal, resting on the handles, to reduce your truck's center of gravity

Contractor Series — Your Key to Efficiency

The Contractor Series concept represents Clemco's commitment to keeping you, the contractor, operating safely and at peak efficiency.

With that in mind, the Contractor Series product line includes safety equipment, nozzles, holders, couplings, and hoses to complement the performance and

reliability of your Contractor Blast Machine — built to the highest quality standards.



Quality — Our Promise: a Well-made Machine

During final assembly, Clemco employees test each component — then double check the entire blast machine for leaks, remote control operation, and overall fit and function.



Clemco has been building blast machines for more than 60 years.

Contractor Blast System



Six cubic foot contractor blast machine

Not just different ... better

Aside from the pressure vessel, everything else about your Contractor Blast Machine looks different from conventional machines. Our engineers started with a blank screen and a mandate to design a versatile system that is as productive as current technology allows.

Details make the difference. The diameter of the formed steel tubing was selected, not just for its structural properties, but for the way it fits comfortably in the average adult hand. This makes moving the cart easier and safer.

Hookup points for blast hose and remote controls are all mounted on the front leg, and a space is provided for your breathing air line, so you spend less time fumbling with connections and more time blasting.



Two cubic foot contractor blast machine

Blast Machine Systems



Four cubic foot contractor blast machine

When your Contractor Blast Machine does need service, you will appreciate our engineer's other mandate — keep it simple.

The unique, Millennium inlet/outlet remote control valve has just two moving parts and can be field serviced with standard tools. The Quantum metering valve handles all conventional abrasives and is designed to be easy to use and easy to maintain.

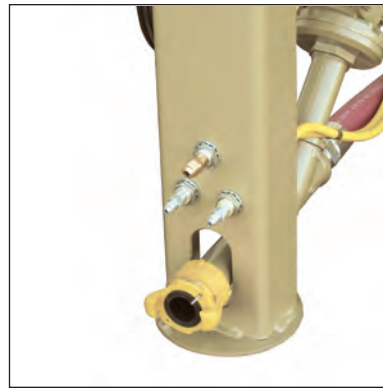

Convenient hookup points for hoses



Weather-tight storage for manuals

Also in the front leg — a weather-tight storage bin for your owner's manuals, so your operating instructions, maintenance schedule, and replacement parts lists are always at your fingertips.



The large hand hole is reinforced with a ring of 3/8-inch steel, cut to conform to the wall of the blast machine and welded inside and out, leaving fewer nooks and crannies where abrasive can collect.

Contractor Systems — All You Need For Blasting

Except abrasive, air hose, and compressed air.

Each system includes:

- Blast machine
- RLX handle assembly
- Quantum abrasive valve
- Abrasive trap
- Air filter
- Millennium remotes
- Nozzle
- Blast hose
- Nozzle holder
- Quick coupling
- Blast hose safety cable
- Blast machine screen
- Apollo respirator*
- Air conditioner (CA systems)
- Respirator hose
- CPF Filter (CA systems)
- Leather gloves
- Apollo lenses
- Coupling gaskets
- Nozzle washers
- Abrasive trap screens
- Nylon ties
- Poly all-weather cover

**Not included but recommended is CMS-3 monitor/alarm for continuous monitoring of breathing air to protect operator from dangerous carbon monoxide gas. (Can be used with high pressure and low pressure respirators.)*

Reliability — Integrated Remote Controls and Metering Valves

The Millennium and Quantum valves were designed, tested and refined simultaneously, so they operate at the same pressures and share common air fittings. There's nothing to adapt, no bushings to reduce, no orifice fittings to mismatch.

The Millennium and Quantum valves share a design philosophy. We design them to last and build them with precision. We incorporate die-cast housings and tough steel actuators.



Millennium Remote Control System

Reliable, integrated remote control valve and exhaust muffler

Shown here as a simple pressure-release system, inlet and outlet functions are combined in the Millennium Remote Control Valve.

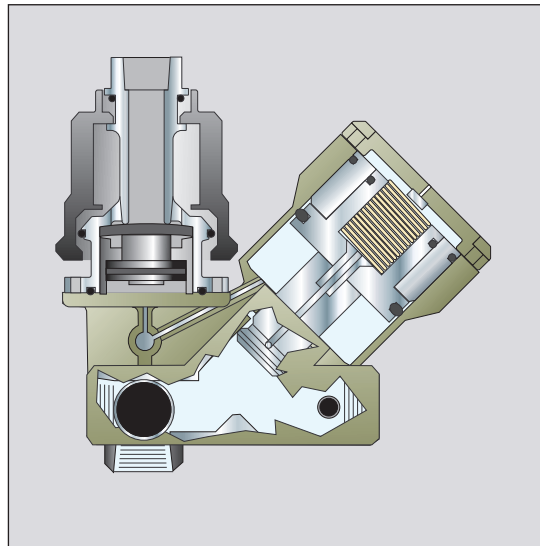

Millennium Remote Control
Valve in closed position.

Millennium Remote Control
Valve in open position.

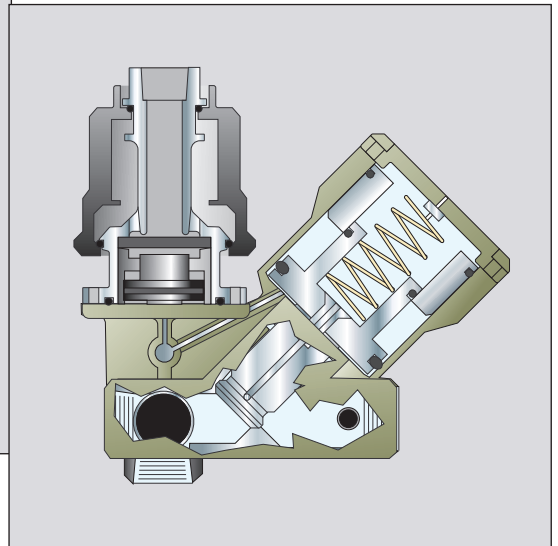

All Contractor Blast Machines come with Clemco's exclusive Millennium pneumatic remote control valve, which combines inlet and outlet functions. It starts and stops faster, so you spend less time waiting, and more time blasting.

Pressing the remote control handle simultaneously actuates both the inlet and outlet portions of the valve. Some systems activate one valve then the other, which can slow response times.

For repetitive short-cycle blasting, order the Contractor Blast Machine configured for pressure-hold operation. It eliminates the delay between the time you actuate the remote control and blasting begins. Also, this system includes an abrasive cut-off switch for remote control actuation of the abrasive flow, which allows air-only blasting to dry surfaces after wetblasting.

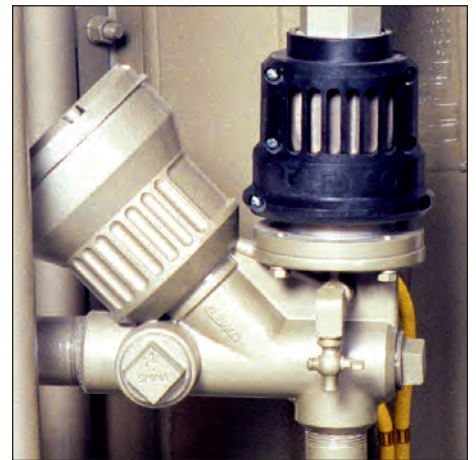

The Millennium pneumatic remote control
valve combines inlet and outlet functions.



Optional
electric
remote
controls

Quantum Metering Valve

Precise manual or automatic control of media

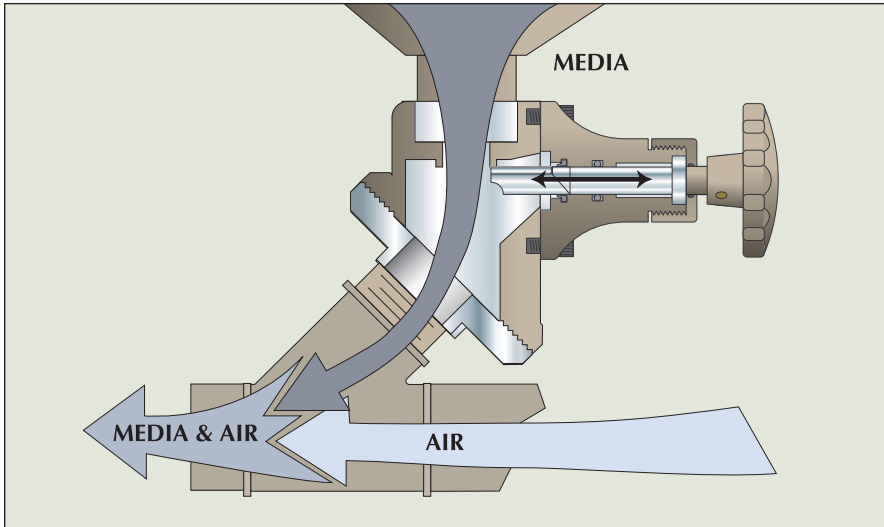

Metering and valve actuation are separate functions in the Quantum. Precision screw control accurately meters all common blast media.

For Complete Control

The Quantum accurately meters all common blast media — from coarse steel grit to slag to fine glass bead. Just empty the blast machine, pour in the new media, and start blasting.

For contractors, the Quantum's flexibility reduces downtime between jobs that require different blast media. For rental outlets, owning Contractor Series systems makes every blast machine ready to roll out the door regardless of the application. Most common blasting media the customer chooses will be compatible.

Metering and valve actuation are separate functions on the Quantum. In fact, the simple metering portion alone is all that's needed for most contractors with pressure-release applications.

Inside the Quantum, a hardened steel metering plate precisely controls the flow of abrasive. The contractor adjusts abrasive flow by turning the knob.

The metering plate, which receives most of the wear, can be replaced in the field in minutes using standard tools.

Quantum — Engineered for Lasting Economy

All parts normally exposed to abrasive

flow are made from durable, wear-resistant material. Even the metering adjustment knob is designed and

built to stand up to real world use and abuse.

The Quantum is designed for precise metering and easy maintenance.

Available in models for manual operation, abrasive cut-off, and pressure-hold applications.

The Quantum's remote control actuator section, which is included only on systems equipped for pressure-hold or remote abrasive cutoff, stops the flow of abrasive positively and instantly.

As with all the remote control valves on your Contractor Blast Machine, the Quantum's actuator has a built-in fail-to-safe feature that stops the flow of abrasive if the signal from the remote control handle is interrupted for any reason.

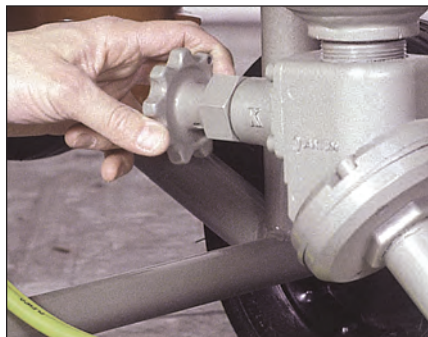

The Quantum Metering Valve features precision adjustment.



Safety — Anticipation of the Unthinkable

Clemco's over six decades in the blasting business has taught us that when it comes to safety, theory is often overtaken by events.

It isn't possible to plan for every contingency but it is possible to anticipate likely dangers and to design equipment that more than half-way meets the real world head-on.

Abrasive impact, dangerous air-borne compounds, sudden failure of equipment and the ever lurking threat of carbon monoxide.

We know what can happen.

We have it covered!

Safety

Personal Protection Equipment



Apollo 600 Supplied-Air Respirators, NIOSH-approved, OSHA-required respiratory protection for the blast operator. HP models are for compressed-air breathing-air supplies; LP models are for use with an ambient air pump. For maximum operator comfort, Apollo DLX models are equipped with a washable and replaceable comfort fit suspension. Standard contractor systems include Apollo 600 with DLX suspension and Clem-Cool air conditioner.

The Clemco CPF 20 and 80 Breathing Air Filter systems are OSHA-required filtering devices that capture contaminants that may be present in the compressed air supply. It does not remove carbon monoxide (CO). The breathing air should be monitored for the presence of CO. See Clemco CO monitoring equipment below.



Carbon Monoxide Monitors/Alarms provide continuous breathing-air monitoring. CMS-2 is field portable for use with high-pressure systems. CMS-3 mounts inside the helmet for use with both high-pressure and low-pressure systems.



Clemco Ambient Air Pumps, offered in three models, provide clean air to any NIOSH-approved low-pressure helmet. Ambient air pumps are available for one to four operators.



Blast Hose Safety Cable helps prevent death, injury, or property damage in the event of coupling failure and helps support blast hose when run vertically or across horizontal spans. Prolongs life of hose; comes in two sizes for 1/2" to 1-1/4" OD and 1-1/2" to 3" OD blast hose.



Clemco Gloves protect your hands from rebounding abrasive and help keep dust and abrasive from entering the blast suit at the wrists.

Comfort



Clemco's Industrial Blast Suit has a heavy cotton fabric back, durable leather front, protecting workers from rebound and keeping out dust and abrasive.



Seasonal Blast Suit represents a cost effective alternative to an industrial suit for occasional or short-term blasting, and for nearby personnel.



Clemco Comfort Vest performS dual functions — safety *and* comfort. Operators are able to control their immediate environment and enjoy a level of comfort absent from most blasting operations. Comfort helps them to avoid distractions resulting from excessive heat or cold and greatly aids productivity. Clemco offers the Comfort Vest with Clem-Cool or Climate Control Tube to allow operators to control their personal environment, whether the situation calls for cooling in the desert or the tropics, or heating in the deep freeze of winter.

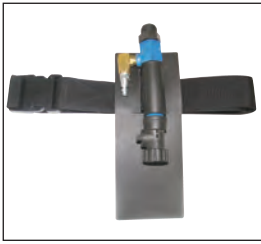

Clem-Cool Air Conditioner offers powerful cooling and is designed with value in mind – economical to replace; no maintenance. Used with Apollo respirators and comfort vests

Apollo Operator Comfort Air Controls



Constant Flow Connector (in HP and LP models) provides a fixed volume at maximum air flow to the respirator with no adjustment.

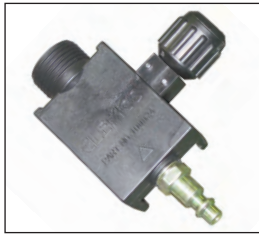

Air Control Valve adjusts the flow of incoming compressed air at the temperature generated by the compressor and the ambient environment.

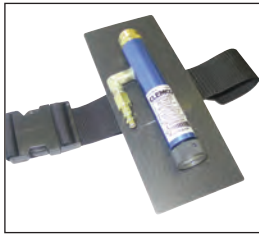

Cool Air Tube provides up to 50° of cooling in an aluminum tube that allows internal maintenance, offering years of service.



Climate Control Tube offers cooling or warming of incoming compressor air, up to 40°, in one convenient device – making it ideal for all seasons.

Communication



WiComm Pro, Clemco's two-way FM radio system, lets operators communicate with supervisors, pot tenders, and each other without stopping work. This can increase the productivity of experienced operators and reduce the training time required for new personnel.

Working Conditions — More Than Feeling Comfortable

On a day when the ambient temperature has weather services issuing excessive heat alerts or the wind-chill factor has the mercury down in the single digits, it is comforting to know these extremes can be overcome and the job can be completed by the deadline.

Whether in the desert or under a bridge spanning a frozen river, Clemco has addressed the problem of operator comfort.

A comfortable operator is better able to focus on his job, making him more efficient and better able to concentrate on the job at hand and on potential safety issues as well.

Performance — The Ideal Combination of Engineering and Energy

Clemco provides the quality tools for your toughest jobs.

Our machine systems are designed for maximum air flow and reduced pressure loss to deliver energy to the blast surface to get the job done — fast.

Contractor Blast Machine Accessories

Rubber-Jacketed Nozzles

The Contractor Series blast machine systems come with TMP series nozzles. These rubber-jacketed, tungsten-carbide lined nozzles offer hundreds of hours of service. They feature wide, deep-pitched *contractor* threading for quick and easy replacement when changing nozzles mid-job or when replacing worn nozzles. The large thread prevents galling commonly experienced with fine-thread nozzles when trapped dust, dirt, and abrasive particles make nozzle removal extremely difficult.



Nylon Couplings and Nozzle Holders

Clemco introduced nylon couplings in the early 1980s and they have become the industry standard. The nylon material is fiber-reinforced so it springs back from most impacts, making them an excellent choice for a long service life. Built-in lock-springs eliminate the need for safety pins.



Nylon nozzle holders and couplings are lightweight, high-impact, and extremely durable — they can even pop back to their original shape after temporary crushing from a car or light truck tire.



SUPA Blast Hose

Another Clemco innovation, the super-flexible, lightweight, blast hose is made with an SBR rubber tube reinforced with rubber-impregnated fiber winding and treated with a static-dissipating compound. It's outer casing is pin-pricked to prevent the formation of air pockets. Its popularity is unsurpassed.

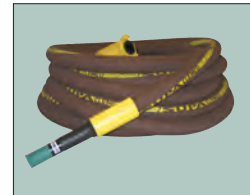

Quality Spares & Consumables

Built to our quality standards, genuine Clemco replacement parts last longer, protect your safety and health, and deliver the maximum performance you demand.



Technical Support

Clemco offers free factory training for every Distributor. For the contractor, we offer detailed operation and maintenance instructions and troubleshooting advice. Every blast machine comes with a complimentary copy of Clemco's Abrasive Blasting Safety Practices booklet to help you protect your workers on the job every day while they perform under the most challenging conditions.



System Components and Options

CONTRACTOR SYSTEMS	Contractor Blast Machine Systems with Apollo HP Respirator			Contractor Blast Machine Systems with Apollo LP Respirator				
Model	2016 CA	2020 CA	2024 CA	2016 AA	2020 AA	2024 AA		
Machine Diameter	16 inches	20 inches	24 inches	16 inches	20 inches	24 inches		
Machine Capacities - Volume in Cu Ft and Lbs of Mineral Abrasive	2 200	4 400	6 600	2 200	4 400	6 600		
System Stock No.	21547	21548	21549	21840	21841	21842		
System Weight	450	550	685	430	530	665		
<i>Note: All Contractor Machines include Millennium Remote Controls with RLX Handle and Quantum Abrasive Metering Valve.</i>								
Blast Machine with CPF Filter	21544	21545	21546					
Blast Machine w/o CPF Filter				21490	21505	21610		
<i>Contractor Systems are equipped with the following:</i>								
Quantum Metering Valve	22845	22845	22845	22845	22845	22845		
Abrasive Trap	02011	02011	02011	02011	02011	02011		
RLX Handle Assembly	10565	10565	10565	10565	10565	10565		
Blast Nozzle	TMP-4 23520	TMP-5 23521	TXP-6 23525	TMP-4 23520	TMP-5 23521	TXP-6 23525		
Blast Hose, SUPA, 50 ft, coupled	1-inch ID 23480	1-inch ID 23480	1-1/4-inch ID 23481	1-inch ID 23480	1-inch ID 23480	1-1/4-inch ID 23481		
Nozzle Holder	NHP-1 04106	NHP-1 04106	NHP-2 04127	NHP-1 04106	NHP-1 04106	NHP-2 04127		
Coupling	CQPS-1 21088	CQPS-1 21088	CQPS-2 08413	CQPS-1 21088	CQPS-1 21088	CQPS-2 08413		
Air Filter with Manual Drain	1-inch 22424	1-1/2 inch 22363	1-1/2 inch 22363	1-inch 22424	1-1/2 inch 22363	1-1/2 inch 22363		
Safety Cable	15013	15013	15013	15013	15013	15013		
Coupling Gaskets, 10-pk	21584	21584	08853	21584	21584	08853		
Nozzle Washers, 10-pk	91024	91024	91026	91024	91024	91026		
Abrasive Trap Screen, 6, shown each	02012	02012	02012	02012	02012	02012		
Nylon Tie, 8, shown each	02195	02195	02195	02195	02195	02195		
Poly All-weather Cover	15097	15143	15143	15097	15143	15143		
Blast Machine Screen	03099	20357	03100	03099	20357	03100		
Apollo 600 with DLX Suspension	25194	25194	25194	25195	25195	25195		
Apollo Respirator Hose, 50 ft.	04415	04415	04415	22510	22510	22510		
CPF-20 Breathing-Air Filter without Base Bracket	22540	22540	22540	Not incl.	Not incl.	Not incl.		
Apollo Lenses - outer, 25-pk	04361	04361	04361	04361	04361	04361		
Apollo lenses - intermediate, 10-pk	24943	24943	24943	24943	24943	24943		
Leather Gloves	02243	02243	02243	02243	02243	02243		
OPTIONAL ITEMS								
Blast Machine Steel Cover	02335	20358	02336	02335	20358	02336		
Carbon Monoxide Monitor/Alarm, CMS-3 Pkg	24612	<i>For Use with ALL Apollo Respirator Models</i>						
Ambient Air Pump, Single-Operator, CALIPSO	25908	<i>For Use with Apollo LP Respirators Only</i>						
Ambient Air Pump, 4-Operator, CAP-4	22530	<i>For Use with Apollo LP Respirators Only</i>						
Ambient Air Pump with Integral Cart, 4-Operator, CAP-4C	22384	<i>For Use with Apollo LP Respirators Only</i>						
Contractor Machines with Millennium Remote Control Options (Factory-Installed)								
	Electric		Abrasive Cut-Off			Pressure-Hold		
	12 Volts	120 Volts	Pneumatic	12 Volts	120 Volts	Pneumatic	E-12 Volts	E-120 Volts
4 cu ft	21509	21538	22554	22541	22543	22545	22547	22549
6 cu ft	21543	21606	22555	22542	22544	22546	22548	22550
Field-Installed Millennium Remote Control Options								
	Converting to Electric		Adding Abrasive Cut-off					
4 cu ft	21678	21679	22551					
6 cu ft	21678	21679	22551					

The Clemco Advantage

**Contractor
Series —
Productivity,
Safety, and
Versatility**

Clemco Industries Corp. has manufactured high-quality abrasive blasting equipment for more than 60 years. The Contractor Series represents the future of portable air-powered abrasive blasting — products designed and built to withstand the rigors of field use, yet packed with features that make them safe, easy to operate, and easy to maintain.

Clemco is proud of its reputation for innovative products and services. Your use of Clemco's products makes that innovation possible. Thank you.

Our products are available exclusively through our vast network of distributors and dealers throughout the U.S. and Canada. Clemco International supports a worldwide network of subsidiaries, licensees, and distributors producing abrasive blast equipment to meet the needs of contractors around the world.



This brochure provided by:



CLEMCO[®]
INDUSTRIES CORP.

Clemco is committed to continuous improvement. Product availability and specifications are subject to change without notice. Consult equipment owner's manual for specifications.

ISO 9001-2008 Certified