

AEROLYTE[®] Systems

By Clemco Industries Corp.



Bicarbonator

Soda Blast Cabinet

**Clean
Strip Paint**

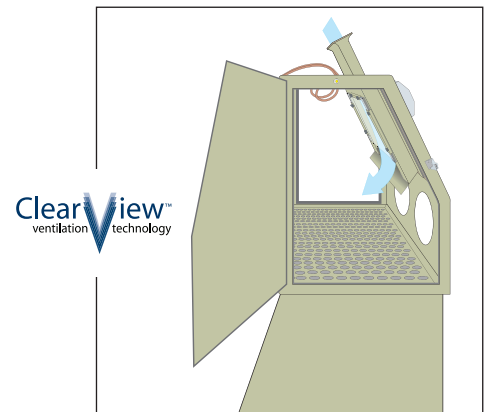

The Bicarbonator pressure blast cabinet, model PSB 2342-600, is designed for use with sodium bicarbonate media for cleaning and paint stripping. Soda media is soft, making it ideal for cleaning without altering or etching delicate surfaces. Soda media is water-soluble, non-toxic, and non-hazardous, simplifying its removal and disposal. Parts with internal cavities are easily rinsed clean. This model is for intermittent blasting, up to two hours per day. For higher-production soda blasting, Aerolyte can configure a pressure cabinet to suit your operation.

The Aerolyte Bicarbonator Cabinet Features

Safety

- Door interlock system interrupts blasting when either door is opened
- Optional time-delay locking system keeps doors locked for predetermined time
- Double-wall, insulated doors, reduce exterior noise
- Full-opening doors with lift-off hinges maximize work chamber capacity and ease loading large parts
- Full-length, neoprene-on-fabric gloves offer long wear life and operator protection
- Dual 15-watt fluorescent lights illuminate the work chamber and stay cool

Productivity

- Patented ClearView™ targeted high-velocity ventilation technology provides exceptional visibility
- Unique air logic system maximizes air and media flow for blasting
- ASME-code pressure vessel, 0.5 cuft capacity, with 1/2" piping
- Reverse-pulse cartridge dust collector immediately evacuates airborne dust and traps 99.7% of dust down to 0.5 micron
- Robust, adjustable chrome latches seal doors tight through years of service

Convenience

- Tilt-out window allows tool-free glass changes in minutes
- Easy-to-reach pressure regulator, gauge, and electric switch
- Built-in air gun conveniently located inside allows part blow-off inside cabinet

Unique patented ClearView™ ventilation technology provides outstanding visibility during soda blasting, unlike any other cabinet on the market.

Common Applications

- Cylinder heads
- Engine parts
- Transmission valve bodies
- Oil pumps
- Gearbox bodies and parts
- Carburetor bodies and parts
- Fiberglass components
- Automotive body parts
- Aircraft parts
- Delicate substrates

S P E C I F I C A T I O N S

COMPLETE SYSTEM

Actual space required depends on equipment configurations, and desired work flow. Allow additional work space for operator and maintenance access.

Cabinet and Dust Collector
49" deep
48" wide
90.5" high

10" Blast Machine and Hopper
22" wide
42.5" high

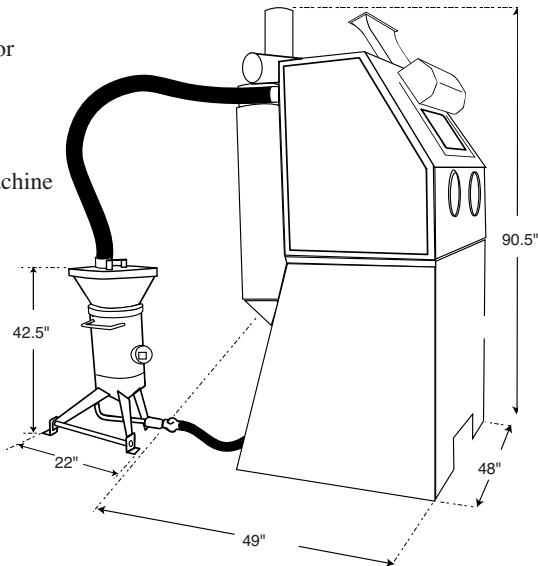

Model Illustrated: PSB 2342-600

CABINET

Working Chamber Size

42" wide (1067 mm)
23" deep (584 mm)
30" high (762 mm)

Window Size (safety glass)

19.5" wide (495 mm)
12.5" high (317 mm)

Door Opening

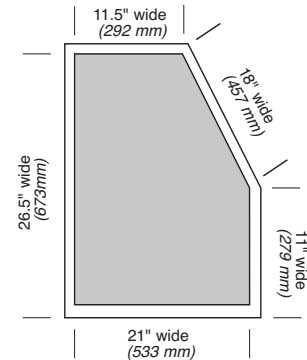

DUST COLLECTOR

The 600 cfm reverse pulse cartridge dust collector traps 99.7% of dust down to 0.5 micron, allowing non-stop, high-production blasting. The polyester-cellulose cartridge is automatically pulse cleaned for maximum filter efficiency. The cartridge can be replaced in minutes.

Note: Parts must be free of oil, water, grease, and other heavy contamination that could clog the dust collector filter.

Filtering Area

120 ft² (11.148 m²)

Dust concentration in exhausted air is nominally 5.0 mg/m³.

NOTE: The Bicarbonator Soda Blast Cabinet incorporates technology covered by US Patent No. 5177911.

ISO 9001 certified. Clemco is committed to continuous product improvement. Specifications are subject to change without notice.

SYSTEM DESCRIPTION

- Model Bicarbonator PSB 2342-600
- Heavy-duty 14-gauge cabinet shell, all-welded construction
- Safety-glass view window, 12" x 19.5"
- Fluorescent lighting with dual 15-watt bulbs
- Heavy-duty industrial-quality adjustable chrome latches
- Unique air-logic system to maximize efficient use of compressed air
- Clear View™ ventilation provides optimal work chamber visibility
- Cabinet-mounted 600 cfm reverse-pulse dust collector with 1 HP motor
- Filter area: 120 square feet
- Dust drum, removable for easy material disposal
- 0.5 cu ft capacity ASME-code pressure vessel

POPULAR ACCESSORIES

- Time-delay Door Locks
- Table/work tray w/internal track
- Turntable
- HEPA Filter

NOZZLE

AIR CONSUMPTION

SIZE	NOZZLE ORIFICE	CFM at 80 PSI	M ³ /mn.at 5,5 BAR
* No. 3	3/16"	38	1,08

*Cabinet is furnished with an ASV-3 stainless steel nozzle.

ELECTRICAL

1HP, 115V, 1PH, 60HZ

ORDERING INFORMATION

Model	Reclaim	Dust Collector	Stock No.	Shipping Wt.
Bicarbonator	N/A	Reverse	27049	875 lbs
PSB 2342-600		Pulse		398 kgs

Distributed By:

CANFIELD & JOSEPH

www.canfieldjoseph.com

800-364-5452