



4000 Series PORTABLE



DeMARCO® INDUSTRIAL VACUUMS

The Portable DeMARCO® Vacuum 4000 Series is precisely engineered and manufactured to the highest standards, therefore providing you with a level of unsurpassed quality, value and performance.

The 4000 Series is ideal for ultra heavy-duty wet/dry material applications that may require up to a 14" ID hose size with pick up capacities up to 48 tons/hour. This design includes a 4-point powerhead air-lift package requiring no manual hand-lift or fork-lift truck for hopper sealing. The Portable 4000 Series may also be connected to a central manifold system with multiple pick up point connections.

YOUR SEARCH STOPS HERE™

DeMARCO® Vacuums are purposely built for decades of heavy-duty use with our exclusive performance features that are virtually maintenance-free. From our heavy gauge steel fabrications, to our time tested quality components and expert machine craftsmen, we are confident to stand behind every vacuum system that carries the DeMARCO® name worldwide by offering our exclusive **Limited LIFETIME Warranty - Nothing Less.**

INDUSTRIES SERVED

FOUNDRY

ALUMINUM
BRONZE
CARBON BLACK
METAL
ORES
SAND CLAYS
STEEL SHOT

FOOD

FLOUR
GRAIN
SALT
SUGAR

MILLS

CHEMICALS
SAWDUST
PAPER
PULP
WOOD CHIPS

MINING

ASPHALT
BRICK
CEMENT
CONCRETE
GRAVEL
LIMESTONE
MINERALS

PLASTIC

FLAKES
POWDER
PELLETS
RESINS

POWER PLANT

COAL
FLY ASH
SLURRY

MISC.

COATING
GLASS
SODA ASH
POWDERS
ETC.

PERFORMANCE

Model	HP	Vacuum (”Hg) Rating*	CFM	Inlet ID Hose Size	Tons/ Hour**
4400	40	16”	950	4”	10
4500	50	16”	1150	5”	14
4750	75	16”	1620	6”	20
4100	100	16”	2110	8”	30
4125	125	16”	2810	10”	36
4150	150	16”	3410	12-14”	48

Above performances are approximate ratings under STP.

* Vacuum capabilities up to 27” Hg available on select models.

** Actual values may differ based upon distance from blower and material characteristics such as bulk density, particle size and operator's efficiency.

DeMARCO® MAXCARTRIDGE™ FILTERS

4000 Series

- Exclusive Long Lasting Custom Design
- Washable and Reusable
- High Burst Strength with Dimensional Stability
- Dimpled, Non-Clogging Open Pleat Design
- Handles Ultra-Fine Powders
- Abrasion and Chemical Resistant
- Efficiencies up to 99.99% @ 0.2 Microns & Above
- Interval Air-Pulse Cleaning for Uninterrupted Vacuuming. No Manual Filter Shaking Required
- Secondary In-line or HEPA Filters Available
- Various Filter Medias Available
- Filter Performance Guarantee

* Minimum 80 PSI Compressed Air Required for Filter Pulse Cleaning During Vacuuming.



DIMENSIONS

Roll Hopper in Cubic Yards	L	W	H
1-1/2	8'-2"	5'-6"	9'-7"
2	8'-5"	6'-7"	9'-4"
2-1/2	8'-4"	6'-7"	10'-5"

Custom dimensions available.
HEPA Filter Option may add to overall height.

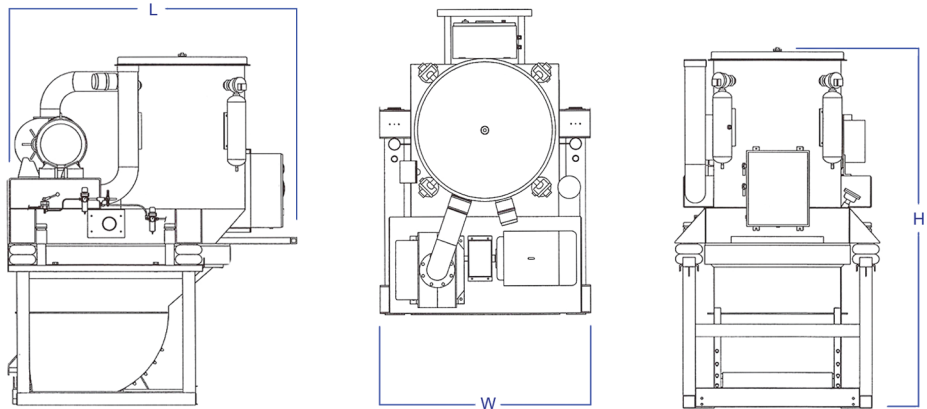

FEATURES & BENEFITS

Patented Features

- DeMARCO® Material Offset Separation Circuit Provides Minimal Carryover to the Filtration Chamber Maximizing Filter Performance.
- Exclusive Line of Cyclone Separators
- DeMARCO® Silencer Base® Muffler
 - Low dBA Rating
 - Compact and Esthetic Design
 - Solid Support Structure for the Drive Package
 - Fork Tine Openings for Vacuum Mobility

Control Panel

- NEMA 4 or 4X Enclosures
- 480V/3PH/60HZ or as Required
- Start/Stop Push-Buttons
- Material High Level Detector with Auto Shutdown
- Differential Pressure Switch for Filter Protection
- Magnehelic and Vacuum Gauges
- Vacuum Pump High Temperature Protection Circuit
- Engineered Electrical Drawings Included
- UL Approved
- **Options:**
 - NEMA 7/9 X-Proof Packages
 - 12V DC Panel
 - PLC Touch Screen Terminal

Drive Package

- High Performance Positive Displacement Vacuum Pumps
- Continuous 24/7 Operation
- Up to 27" Hg (Mercury) Available
- High Energy Efficient Electric Motors
- V-Belt or Direct Drive
- Gas, Diesel and LPG Options

Roll Hopper and Structural Stand

- 1-1/2, 2 or 2-1/2 Material Collection Roll Dump Hoppers with Safety Latch and Skid Mounting Base
- Heavy-Duty Structural Support Stand.
- 4-Point Powerhead Air-Lift Package. Hand-Lift or Fork-Lift Truck Required for Hopper Sealing
- Optional Over-the-Road Trailer Mounted or In-Plant 2-Wheel/4-Wheel Tow Packages Available

Custom Engineered Vacuums

Our full service custom engineering department is dedicated to provide customer focused solutions for your toughest applications.

DeMarco Industrial Vacuum Corp
PO Box 1138
Crystal Lake, IL 60039 USA

P: 815.344.2222
F: 815.344.2223
DeMarcoVacuums.com
Sales@DeMarcoVacuums.com

