



Abrasive Blast Systems, Inc.
 418 NE 14th St.
 Abilene, KS. 67410
 Phone: 785-263-3786, Fax: 785-263-4633
 abs@jc.net

SRC
BLAST & RECOVERY SYSTEM



-1 Cubic Foot storage hopper for all abrasive types.
 Foot valve blast control.

-Abrasive reclaiming system with airwash and screening for efficient processing of abrasive for re-use.

-Large window for viewing, heavy duty gloves for comfortable blasting.

-Reverse pulse cartridge dust collector and high static blower.

-Regulator and air filter.

-Sealed, gasketed access and inspection doors make the system clean and environmentally friendly.

- 115V / single phase power requirement, no transformers needed.

- 3/16" or 1/4" tungsten carbide blast nozzle, separate blow off air.

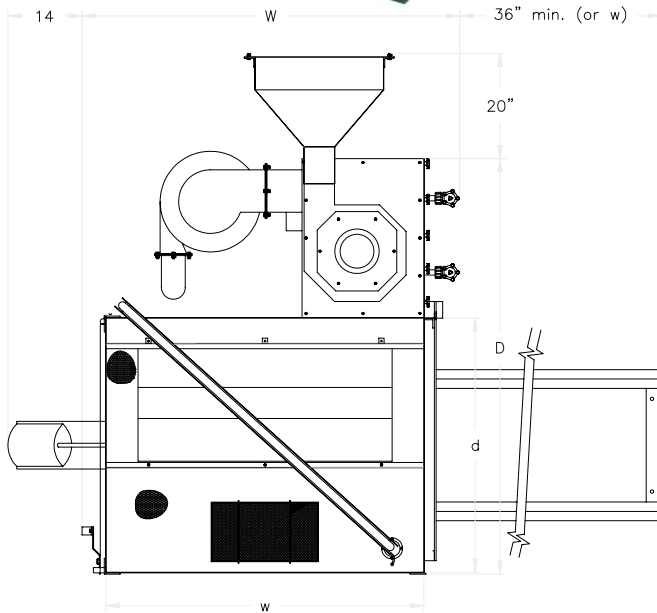

SRC	Overall Dimensions			Working Dimensions			Door Opening	
	W	D	H	w	d	h	W	H
3224	36	48	79	32	24	36	20	32
4228	51	58	79	42	28	36	24	32
4836	58	69	92	48	36	36	32	32
4848	58	79	93	48	48	36	32	32
6048	62	68	93	60	48	36	44	32



Abrasive Blast Systems, Inc.

418 NE 14th St.

Abilene, KS. 67410

Phone: 785-263-3786, Fax: 785-263-4633

abs@jc.net

-Options.

- Workcar with track extension for easy loading.**
- Stationary or workcar mounted turntable.**
- Vertical sliding door for tight floor plans and using work cars..**
- Tumble basket attachment for small parts batching.**
- Rubber lined cabinet and reclaimers for coarse abrasives.**
- Aerated feed valves for fine abrasives.**
- Automatic pulse for dust collector.**
- Special electric requirements, i.e. 3 phase.**
- HEPA Filter**



Tumble basket attachment is used for blasting small parts in a batch process. Adjustable timer and nozzle holder included.



Aerated feed valves are used for extremely fine abrasives, where flowability is important.



Work car and track extension make cabinet loading and unloading easy and safe.



HEPA filter on discharge adds peace of mind when using special materials.