



MARTIN® WHIRLWIND™

High-Frequency Turbine Vibrator

The unique urethane-encapsulated turbine in the **MARTIN® WHIRLWIND™ High-Frequency Turbine Vibrator** produces more power with less noise than any other high-force/high-frequency pneumatic turbine vibrator. With an output of over 10,000 lb-f (45 kN), depending on the application, the MARTIN® WHIRLWIND™ High-Frequency Turbine Vibrator doubles the force output of the most powerful competitive models. Units mount easily to cradle lug brackets or railcar wedge brackets, and operate quietly to meet OSHA noise requirements.



BENEFITS

- **Moves More Material**
Larger unbalance creates greater force output to move your material.
- **Saves Your Hearing**
Testing shows noise level from 6 to 10 dB less than competitive models and within OSHA noise limits.
- **One-Worker Portability**
Built-in handle provides easy portability for use in railcar unloading or on pre-cast forms applications.
- **Reduces Maintenance Costs**
Long-life, high-speed sealed bearings need no lubrication.
- **Reduces Your Investment**
Longer life and lower air consumption than competitive models cuts your lifetime cost of ownership.
- **Satisfaction Guaranteed**
Covered by Martin Engineering's *Absolutely, Positively, No Excuses* Guarantee.

TYPICAL APPLICATIONS

- **Concrete Consolidation**
Allows fast placement and high-strength consolidation, provides excellent surface finish. High force reduces the number of vibrators required per form; low air consumption cuts operating costs.
- **Railcar Unloading**
High frequency and high force provide efficient unloading of compacted fine powders like dry chemicals or foodstuffs.
- **Permanent or Portable Mounting**
For applications like material compaction, storage vessel evacuation, or material feeding.

SPECIFICATIONS

*	40 psi (2.76 bar)	60 psi (4.14 bar)	80 psi (5.51 bar)
Frequency VPM	6500	8400	9300
Force Output lb-f (kg-f)	5158 (2340)	8615 (3908)	10,560 (4790)
Air Consumption as measured on Dwyer gauge cfm (L/min)	21 (595)	25 (708)	28 (793)

* Results from a 10,000 lb (4535.9 kg) test block.

DIMENSIONS—in. (mm)

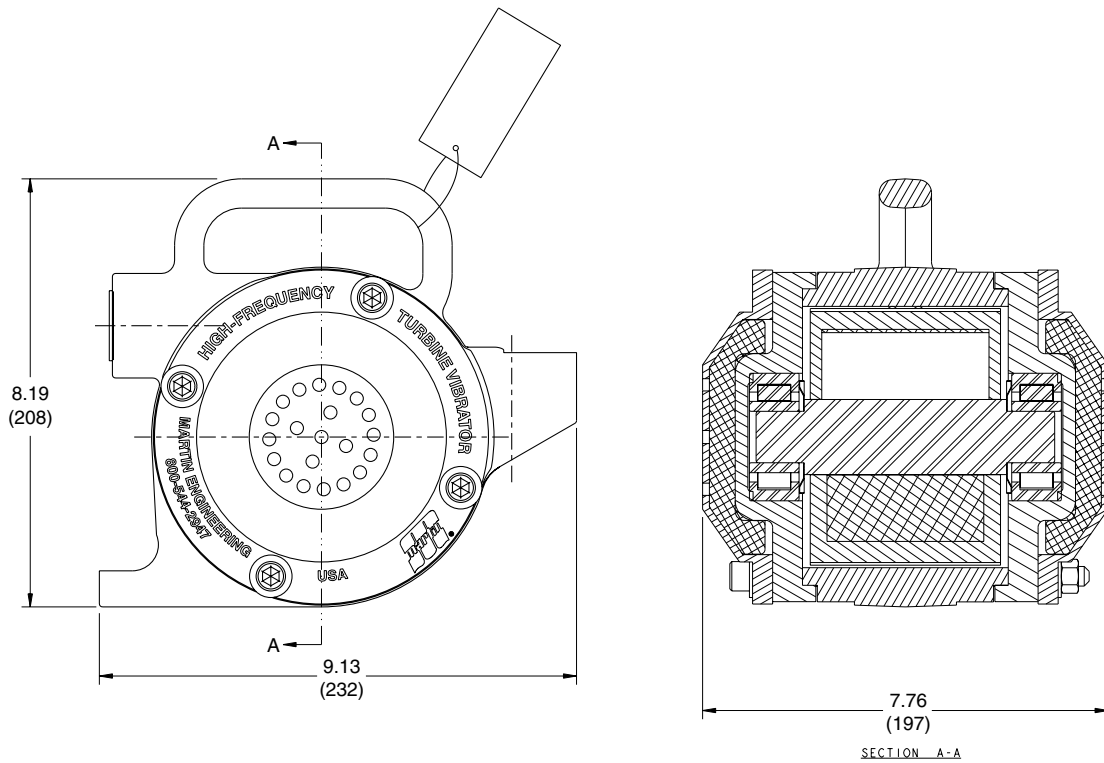

ORDER INFORMATION

	P/N	Shipping Weight lb [kg]
Vibrator	37628	38 [17.2]
Vibrator w/ Cradle Lug Bracket	37628-C	48 [21.8]
Vibrator w/ Wedge Bracket	37628-W	64 [29.0]

Patents and patents pending, © Registered trademark of Martin Engineering Company in the U.S. and other select locations. Additional information can be obtained at www.martin-eng.com/trademarks.

QUALITY MANAGEMENT SYSTEM
CERTIFIED BY DNV
ISO 9001



MARTIN ENGINEERING USA
One Martin Place
Neponset, IL 61345-9766 USA
800-544-2947 or 309-594-2384
FAX: 309-594-2432
www.martin-eng.com