

GAS MINIATURE LIFT OUT FURNACE

✓ **SUITABLE FOR MANY APPLICATIONS WHERE SMALL QUANTITIES OF MOLTEN METAL ARE REQUIRED AT REGULAR OR IRREGULAR INTERVALS**



▲ Morgan's Miniature Crucible Furnace.

FURNACE DESCRIPTION

The steel furnace shell is lined with a high temperature, robust, insulating refractory for optimum efficiency. The furnace is supplied complete with an industrial standard, automatic burner, manufactured to EN746/2. The integral fan and separate control operate from a standard single phase power socket providing full flame failure protection.

IDEAL APPLICATIONS

- Foundry and laboratory test melts
- Making or remelting key alloys
- Engineering societies and clubs
- Alloying tests
- University & college laboratories
- Art metal workers

FUEL TYPES

The fully automatic burner is rated at 2.5 therms/hour (63 kcal x 10³) and can use the following gaseous fuels:

Natural Gas: 9000 kcal/m³ (1000 Btu/ft³)

Propane: 22000 kcal/m³ (2500 Btu/ft³)

Butane: 28000 kcal/m³ (3200 Btu/ft³)

Supply pressure

Minimum 15 millibar

Maximum 50 millibar

Electrical supply

220-240 volt 50 Hz single phase

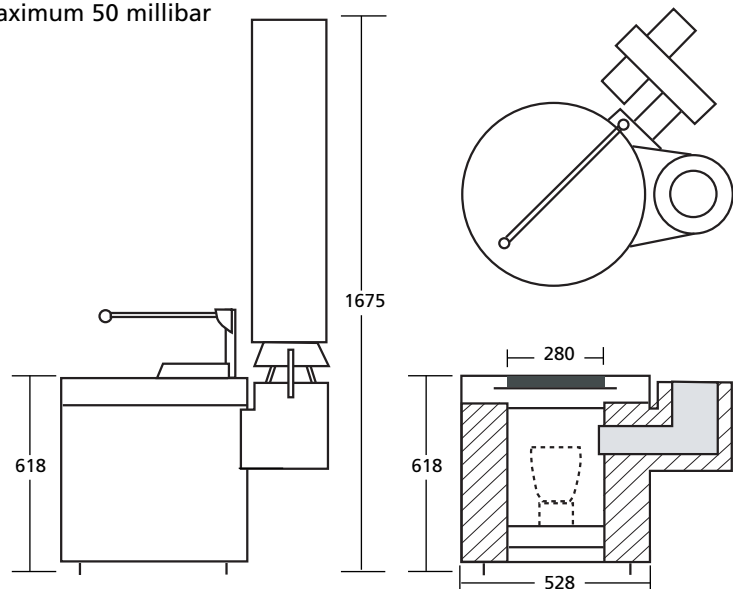

PERFORMANCE DATA

METAL	ALUMINIUM TO 720°C	BRASS TO 1000°C	GUN METAL TO 1150°C	COPPER TO 1200°C
Capacity (kg)	4.5	15	15	15
Crucible	up to size AX12			
Time for Hot Start (minutes)	11	18	20	30
Fuel Consumption per Melt kcal x 10 ³	11.3	18.9	21	31.5
therms	0.45	0.75	0.83	1.25

Above data based on optimum foundry conditions. For normal foundry operations a performance of 90% of these ratings is typical.

SPECIFICATIONS

SHIPPING (approximate)	
NETT WEIGHT	250 kgs
GROSS WEIGHT	320 kgs
VOLUME	1.8m ³



For additional information on Morgan MMS' products & services or to find a location nearest to you, please visit:

www.morganmms.com

Morgan
Molten Metal Systems