

**BEACON
LED BLAST LIGHT
O. M. 27765**

**DATE OF ISSUE: 07/14
REVISION: A, 08/14**

 WARNING

Do not use this equipment until you have READ this MANUAL and YOU UNDERSTAND its contents. *

These WARNINGS are included for the health and safety of the operator and those in the immediate vicinity.

***If you are using a Clemco Distributor Maintenance and Parts Guide, refer to the orange warnings insert preceding the Index before continuing with the enclosed instructions.**

Electronic files include a Preface containing important information.

© 2014 CLEMCO INDUSTRIES CORP.
One Cable Car Dr.
Washington, MO 63090
Phone (636) 239-4300
Fax (800) 726-7559
Email: info@clemcoindustries.com
www.clemcoindustries.com



WARNING

- Employers are responsible for identifying all job site hazards, educating and training all persons who will operate and maintain these products, and ensuring that all blast operators and their assistants understand the warnings and information contained in these instructions relating to safe and proper operation and maintenance of this equipment.
- Serious injury or death can result from failure to comply with all Occupational Safety and Health Administration (OSHA) regulations and all manufacturer's instructions.
- This equipment is not intended for use in any area considered hazardous per National Electric Code NFPA 70 2011, Article 500.
- Read this document and follow all instructions before using this equipment.

OSHA regulations relating to abrasive blasting are contained in the Code of Federal Regulations, Title 29 (29 CFR 1910 General Industry; 1915 Maritime; 1926 Construction). The most pertinent include: 1910.94 Ventilation, 1910.95 Occupational Noise Exposure, 1910.132 Personal Protective Equipment, 1910.133 Eye and Face Protection, 1910.134 Respiratory Protection, 1910.135 Head Protection, 1910.244 (b) Remote Controls. Consult www.osha.gov for complete information.

NOTICE TO PURCHASERS AND USERS OF OUR PRODUCTS AND THIS INFORMATIONAL MATERIAL

Clemco proudly provides products for the abrasive blast industry and is confident that industry professionals will use their knowledge and expertise for the safe and efficient use of these products.

The products described in this material, and the information relating to these products, are intended for knowledgeable, experienced users.

No representation is intended or made as to: the suitability of the products described here for any purpose or application, or to the efficiency, production rate, or useful life of these products. All estimates regarding production rates or finishes are the responsibility of the user and must be derived solely from the user's experience and expertise, not from information contained in this material.

It is possible that the products described in this material may be combined with other products by the user for purposes determined solely by the user. No representations are intended or made as to the suitability of or engineering balance of or compliance with regulations or standard practice of any such combination of products or components the user may employ.

Abrasive blast equipment is only one component of an abrasive blasting job. Other products, such as air compressors, air filters and receivers, abrasives, scaffolding, hydraulic work platforms or booms, equipment for lighting, painting, ventilating, dehumidifying, parts handling, or specialized respirators or other equipment, even if offered by Clemco, may have been manufactured or supplied by others. The information Clemco provides is intended to support the products Clemco manufactures. Users must contact each manufacturer and supplier of products used in the blast job for warnings, information, training, and instruction relating to the proper and safe use of their equipment.

GENERAL INSTRUCTIONS

This material describes some, but not all, of the major requirements for safe and productive use of blast machines, remote controls, respirator systems, and related accessories. All equipment and accessories must be installed, tested, operated and maintained only by trained, knowledgeable, experienced users.

The blast operator and all workers in the vicinity must be properly protected from all job site hazards including those hazards generated by blasting.

Work environments involving abrasive blasting present numerous hazards. Hazards relate to the blast process from many sources that include, but are not limited to, dust generated by blasting or from material present on the surface being blasted. The hazards from toxic materials may include, but are not limited to, silica, cyanide, arsenic, or other toxins in the abrasives or in the coatings, such as lead or heavy metals. Other hazards from toxins include, but are not limited to, fumes from coating application, carbon monoxide from engine exhaust, contaminated water, chemicals or asbestos. In addition, physical hazards that may be present include, but are not limited to, uneven work surfaces, poor visibility, excessive noise, and electricity. Employers must identify all job site hazards and protect workers in accordance with OSHA regulations.

Never modify Clemco equipment or components or substitute parts from other manufacturers for any Clemco components or parts. Any unauthorized modification or substitution of supplied-air respirator parts violates OSHA regulations and voids the NIOSH approval.

IMPORTANT

Contact Clemco for free booklets:

Blast Off 2 – Guide to Safe, Productive, and Efficient Abrasive Blasting, and Abrasive Blasting Safety Practices – Guide to Safe Abrasive Blasting.

Clemco Industries Corp. One Cable Car Drive Washington MO 63090
Tel: 636 239-4300 — Fax: 800 726-7559
Email: info@clemcoindustries.com
Website: www.clemcoindustries.com

OPERATIONAL INSTRUCTIONS

OPERATOR SAFETY EQUIPMENT

WARNING

- OSHA regulation 1910.134 requires appropriate respiratory protection for blast operators and workers in the vicinity of blasting. These workers must wear properly-fitted, properly-maintained, NIOSH-approved, respiratory protection that is suitable for the job site hazards. Blast respirators are to be worn only in atmospheres not immediately dangerous to life or health from which wearers can escape without use of the respirator.
- The employer must develop and implement a written respiratory protection program with required worksite- specific procedures and elements for required respirator use. The employer must provide effective training to employees who are required to use respirators. The training must be comprehensive, understandable, and recur annually, and more often if necessary.
- NEVER use abrasives containing more than one percent crystalline silica. Fatal diseases, such as silicosis, asbestosis, lead or other poisoning, can result from inhalation of toxic dusts, which include, but are not limited to, crystalline silica, asbestos, and lead paint. Refer to NIOSH Alert 92-102; and OSHA CPL 03-00-007: “National Emphasis Program – Crystalline Silica”, in which OSHA describes policies and procedures for implementing a national emphasis program to identify and reduce or eliminate health hazards from exposure to crystalline silica. Numerous topics associated with the hazards of crystalline silica in silica blasting sand can be found on [http:// osha.gov/](http://osha.gov/). Clemco urges users of silica blasting sand to visit this website, and read and heed the information it contains.
- Always make sure the breathing air supply (respirator hose) is not connected to plant lines that supply gases that include, but are not limited to, oxygen, nitrogen, acetylene, or other non-breathable gas. Never modify or change respirator air line connections without first testing the content of the line for safe breathing air. Failure to test the line may result in death to the respirator user.

- Breathing air quality must be at least Grade D, as defined by the Compressed Gas Association specification G-7.1, per OSHA Regulation 29 CFR 1910.134. When compressed air is the breathing air source, a Clemco CPF (suitable sorbent bed filter) should be used. Respirator hose connecting the respirator to the filter must be NIOSH approved. Non- approved hose can cause illness from chemicals employed to manufacture the hose.

- All workers must always wear NIOSH-approved respirators when any dust is present. Exposure to dust can occur when handling or loading abrasive, blasting, cleaning up abrasive, or working in the vicinity of blasting. Before removing the respirator, test the air with a monitoring device to ensure it is safe to breathe.

- Clemco respirators DO NOT remove or protect against carbon monoxide or any other toxic gas. Monitoring devices must be used in conjunction with the respirator to ensure safe breathing air. Always locate compressors and ambient air pumps where contaminated air will not enter the air intake.

- Always use Clemco lenses with Clemco respirators; installing non-approved lenses voids the NIOSH approval. Respirator lenses are designed to protect the wearer from rebounding abrasive; they do not protect against flying objects, heavy high-speed materials, glare, liquids, or radiation.

INDUSTRY ORGANIZATIONS

For additional information, consult:

Occupational Safety and Health Administration (OSHA) - www.osha.gov

Compressed Gas Association (CGA) - www.cganet.com

The Society for Protective Coatings (SSPC) - www.sspc.org

National Association of Corrosion Engineers (NACE) - www.nace.org

American Society for Testing and Materials (ASTM) - www.astm.org

National Institute of Occupational Safety and Health (NIOSH) - www.niosh.gov

American National Standards Institute (ANSI) - www.ansi.org

PREFACE

BLAST MACHINES AND REMOTE CONTROLS

WARNING

OSHA regulation 1910.169 describes the necessity of pressure relief valves on compressed air equipment. Do not operate blast machines with air compressors that are not equipped with properly functioning pressure relief valves.

OSHA regulation 1910.244(b) requires the use of remote controls on blast machines.

Serious injury or death can result from many sources, among them:

- Involuntary activation of the remote controls. Never modify or substitute remote control parts; parts are not compatible among different manufacturers. Welding hose is not suitable for remote control hose. Its ID and material composition make it unsafe for remote control use.
- Exceeding the maximum working pressure. Clemco blast machines are built to ASME-code and carry a 'U' or 'UM' stamp, and National Board/serial number. Every machine is marked with its maximum working pressure. Never exceed the maximum working pressure limits of the blast machine.
- Uncontrolled blast stream. High-velocity abrasive particles will inflict serious injury. Always point the blast nozzle in the direction of the blast surface only. Keep unprotected workers out of the blast area.
- Welding on the blast machine. Never weld on the blast machine; welding voids the National Board approval and may affect the dimensional integrity of the vessel.
- Moving the blast machine. Never manually move a blast machine containing abrasive, any machine containing abrasive must be moved with appropriate mechanical lifting equipment.

HOSES, COUPLINGS, AND NOZZLE HOLDERS

- The inside diameter (ID) of air hoses, fittings, and connections should be at least four times larger than the nozzle orifice size. Blast hose ID should be three to four times the size of the nozzle orifice. Example: a #6 nozzle (3/8" diameter orifice) calls for 1-1/2" ID blast hose and 1-1/2" ID or larger compressor hose. All hose runs should be kept as short as possible and run in as straight a line as possible to reduce pressure loss.
- To install, squarely cut the end of the hose so that it fits snugly against the coupling or hose end shoulder. Always use the screws recommended by the manufacturer ensuring that they do not penetrate the inner wall. Make sure the couplings tightly fit the hose. Install cotter pins at every connection or use couplings with built-in lock-springs to prevent disengagement. Install safety cables at all connections to prevent whipping if hoses disengage or blow out.

MAINTENANCE AND REPAIR

- Completely read and follow all service instructions and recommended maintenance intervals. Always shut off compressor and depressurize blast machine before performing any maintenance. At every service interval, clean all filters, screens, and alarm systems. If spring-loaded abrasive valves are used, always cage spring before disassembly.

WARRANTY

The following is in lieu of all warranties, express, implied or statutory, and in no event shall seller or its agents, successors, nominees or assignees, or either, be liable for special or consequential damage arising out of a breach of warranty. This warranty does not apply to any damage or defect resulting from negligent or improper assembly or use of any item by the buyer or its agent or from alteration or attempted repair by any person other than an authorized agent of seller. All used, repaired, modified, or altered items are purchased "as is" and with all faults. In no event shall seller be liable for consequential or incidental damages. The sole and exclusive remedy of buyer for breach of warranty by seller shall be repair or replacement of defective parts or, at seller's option, refund of purchase price, as set forth below

1. Seller makes no warranty with respect to products used other than in accordance hereunder.
 2. On products seller manufactures, seller warrants that all products are to be free from defects in workmanship and materials for a period of one year from date of shipment to buyer, but no warranty is made that the products are fit for a particular purpose.
 3. On products which seller buys and resells pursuant to this order, seller warrants that the products shall carry the then standard warranties of the manufacturers thereof, a copy of which shall be made available to the customer upon request.
 4. The use of any sample or model in connection with this order is for illustrative purposes only and is not to be construed as a warranty that the product will conform to the sample or model.
 5. Seller makes no warranty that the products are delivered free of the rightful claim of any third party by way of patent infringement or the like.
 6. This warranty is conditioned upon seller's receipt within ten (10) days after buyer's discovery of a defect, of a written notice stating in what specific material respects the product failed to meet this warranty. If such notice is timely given, seller will, at its option, either modify the product or part to correct the defect, replace the product or part with complying products or parts, or refund the amount paid for the defective product, any one of which will constitute the sole liability of the seller and a full settlement of all claims. No allowance will be made for alterations or repairs made by other than those authorized by seller without prior written consent of seller. Buyer shall afford seller prompt and reasonable opportunity to inspect the products for which any claim is made as above stated.
- Except as expressly set forth above, all warranties, express, implied or statutory, including implied warranty of merchantability, are hereby disclaimed.

PREFACE

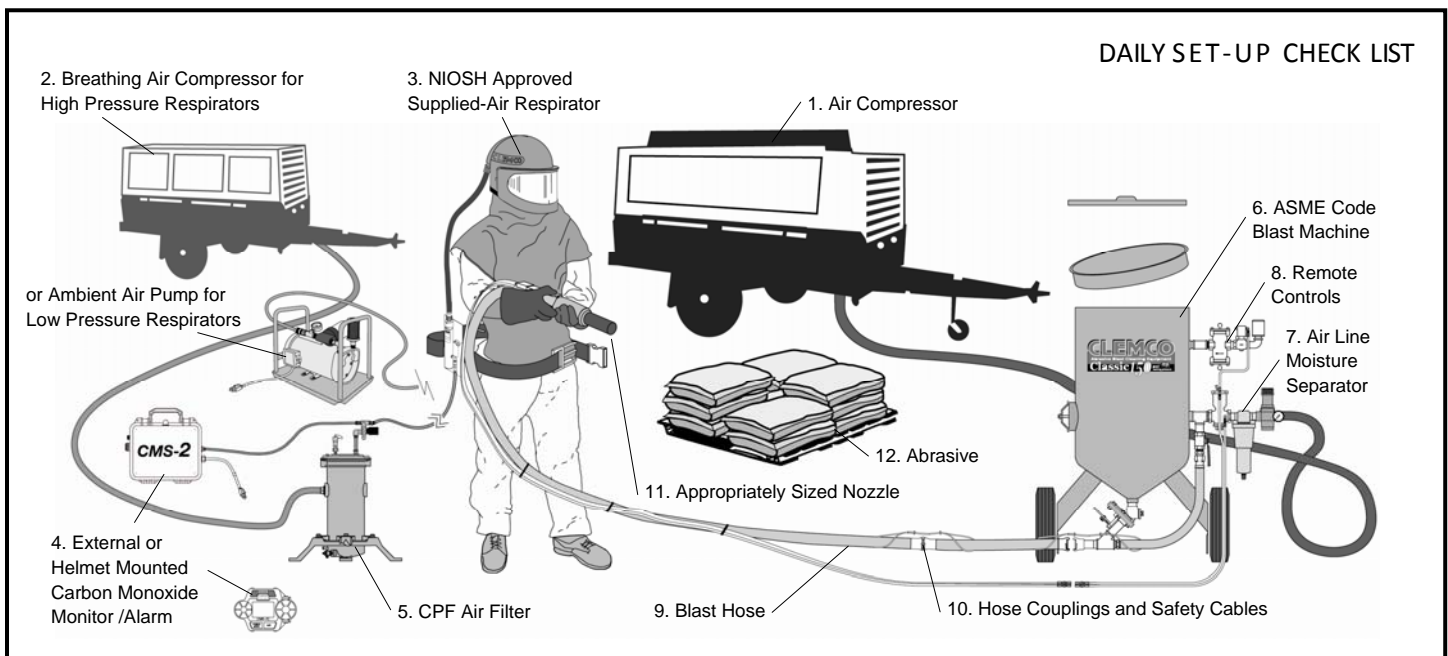

DAILY SET-UP CHECK LIST

Make sure all blast operators are properly trained and suitably attired with a blast suit, safety boots, leather gloves, respiratory and hearing protection. Every day before start up, check all equipment components, including piping, fittings, and hoses, and valves, for leaks, tightness, and wear. Repair or replace as needed. Use the following checklist.

- 1. PROPERLY-MAINTAINED AIR COMPRESSOR** sized to provide sufficient volume (cfm) at given pressure for nozzle and other tools. ADD 50% volume (cfm) reserve to allow for nozzle wear. Use large compressor outlet and air hose (at least 4 times the nozzle orifice diameter). For oil-lubricated compressors, the employer shall use a high- temperature or carbon monoxide alarm, or both, to monitor carbon monoxide levels. If only high-temperature alarms are used, the air supply shall be monitored at intervals sufficient to prevent carbon monoxide in the breathing air from exceeding 10 ppm. Follow the manufacturer's checklist and maintenance instructions.
- 2. BREATHING-AIR COMPRESSOR** (or oil-less ambient air pump) capable of providing Grade D quality air, located in a dust free area. Read # 1 above.
- 3. CLEAN, PROPERLY-MAINTAINED NIOSH-APPROVED SUPPLIED-AIR RESPIRATOR** worn by blast operators, and other workers exposed to blast dust. Make sure all respirator components are in place — all lenses, inner collar, and cape. Thoroughly inspect all components for wear. The NIOSH approval (approval number is listed in the owner's manual) is for a complete assembly from point of attachment on the CPF (sorbet bed) filter to the complete respirator. Substitution of any part voids the NIOSH approval.
- 4. CARBON MONOXIDE MONITOR/ALARM** installed at the CPF filter or inside the supplied-air respirator for monitoring for the presence of deadly CO gas and warning the operator(s) when the CO level reaches an unacceptable level. When an ambient air pump is used for breathing air, a CO monitor provides a measure of safety. Read # 1 above.
- 5. BREATHING-AIR FILTER (OSHA-REQUIRED sorbet bed filter)** for removal of moisture and particulate matter in the compressed air breathing-air supply. Monitor the condition of the cartridge and replace when odor is detected or at 3 month intervals, whichever comes sooner. The breathing air filter does NOT detect or remove carbon monoxide (CO). Always install a CO monitor/alarm.
- 6. BLAST MACHINE** (bearing U or UM stamp, National Board Number, and Maximum Working Pressure) sized to hold a 30-minute abrasive supply. Examine pop-up valve for alignment. Check piping, fittings, screens, valves for tightness, leaks, and wear. Always ground the machine to eliminate hazard of static shock. Install a blast machine screen to keep out foreign objects. Use a blast machine cover if left outdoors overnight. Never exceed the maximum working pressure of the vessel.
- 7. AIR LINE FILTER** (moisture separator) installed as close as possible to the blast machine inlet and sized to match the size of the inlet piping or larger air supply line. Clean filter and drain often. Damp abrasive causes operational problems.
- 8. REMOTE CONTROLS** are required by OSHA and must be in perfect operating condition. Test and check all components to ensure all parts are present and fully functional. Use genuine replacement parts. NEVER mix parts from different manufacturers. Never use welding hose for remote control hose.
- 9. BLAST HOSE** should have an inside diameter sized to suit the blast nozzle. The ID should be three to four times the size of the nozzle orifice diameter. Blast hose should be arranged in as straight a line as possible from the blast machine to the work area, avoiding sharp bends.
- 10. COUPLINGS AND NOZZLE HOLDERS** should fit snugly on the hose and be installed with manufacturer recommended screws. Coupling lugs must snap firmly into locking position. Gasket must always be used to form a positive seal, and cotter pins must be installed. Replace gasket when wear, softness or distortion is detected. Check nozzle holder for thread wear; replace at any sign of wear. Install safety cables at all connections.
- 11. NOZZLE** orifice size should be checked and nozzle replaced when worn 1/16" from original size. (No. 5 nozzle has 5/16" orifice diameter; replace when it measures 3/8"). Threads should be inspected daily for wear and nozzle should be replaced when wear is detected. Always use a nozzle washer.
- 12. ABRASIVE** must be a material specifically manufactured for blasting. It should be properly sized for the job. Check material safety data sheet for free-silica, cyanide, arsenic, lead and other toxins and avoid use when these toxic, harmful substances are present.
- SURFACE TO BE BLASTED** should be examined for hazardous substances. Take appropriate protective measures as required by OSHA to ensure the blast operator, other workers in the vicinity, and any bystanders are properly protected.

©Clemco Industries Corp., Stock No. 20954P, 0692 Rev. F, 06/12

1.0 INTRODUCTION

1.1 Scope of manual

1.1.1 This manual covers the setup, operation, maintenance, and replacement parts of the Clemco Beacon blast light.

1.1.2 These instructions contain important safety information. All operators and personnel involved with the abrasive blast process must read and understand the contents of these instructions, including the orange cover. It is equally important that the operator is trained and qualified to safely operate the blast machine and remote controls, and all other equipment used with the blast machine.

1.1.3 All personnel involved with the abrasive blasting process must be made aware of the hazards associated with abrasive blasting. The Clemco booklet "Abrasive Blasting Safety Practices" is included with every blast machine, and contains important safety information about abrasive blasting that may not be included in equipment operation manuals. To order additional copies, visit www.clemcoindustries.com or email info@clemcoindustries.com.

1.2 Safety Alerts

1.2.1 Clemco uses safety alert signal words, based on ANSI Z535.4-2011, to alert the user of a potentially hazardous situation that may be encountered while operating this equipment. ANSI's definitions of the signal words are as follows:



This is the safety alert symbol. It is used to alert you to potential physical injury hazards. Obey all safety messages that follow this symbol to avoid possible injury or death.

NOTICE

Notice indicates information that is considered important, but not hazard-related, if not avoided, could result in property damage.

CAUTION

Caution indicates a hazardous situation that, if not avoided, could result in minor or moderate injury.

WARNING

Warning indicates a hazardous situation that, if not avoided, could result in death or serious injury.

DANGER

Danger indicates a hazardous situation that, if not avoided, will result in death or serious injury.

1.3 General Description

1.3.1 The Beacon is available in four models:

Two 120-Volt AC models: Available with 50 foot or 100 foot power supply cables and u-ground plug, which plug into any 120-VAC power source.

Two 12-Volt DC models: Available with 50 foot or 100 foot power supply cables and color coded spring clamps, to connect to a battery or other 12-VDC power source.

120-VAC models include an integral 12-VDC power supply that converts 120-VAC to 12-VDC; all models provide 12-Volt DC power to the light.

The Beacon is a high-intensity LED light, to attach to a convenient location on the blast hose, nozzle holder, or nozzle, for lighting the blasting surface. The Beacon is ideally suited for lighting the blast surface in dimly lit areas. It can also be attached to scaffolding, bracing, or other surfaces as needed to provide additional lighting in low-light blasting spaces.

1.4 Components

1.4.1 The components of the Beacon blast light are shown in Figure 1, and include.

One of the following light assemblies:

- 12-Volt DC assembly with 50-ft. supply cable
- 12-Volt DC assembly with 100-ft. supply cable
- 120-Volt AC assembly with 50-ft. supply cable
- 120-Volt AC assembly with 100-ft. supply cable

Two nylon cable ties

2-Ft. Adhesive-backed gasket

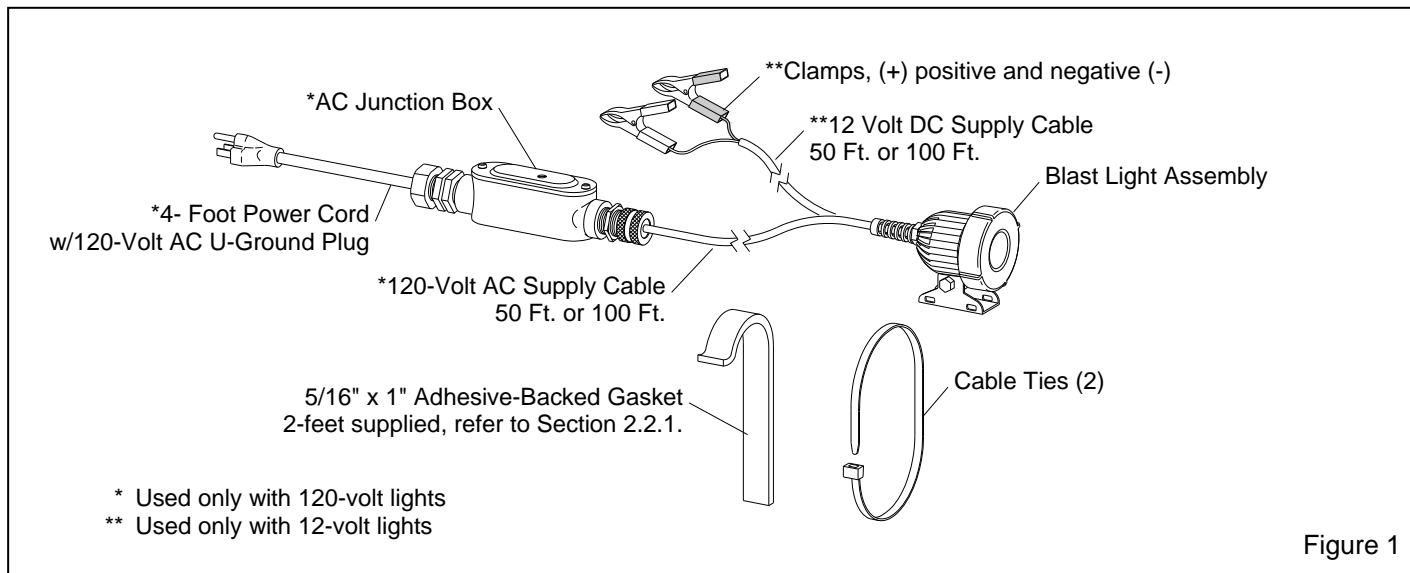

Figure 1

2.0 SET-UP

2.1 Assemble Mount to Light Assembly Refer to Figure 2

2.1.1 Slide the light mount into the slot on the light assembly; the mount is tapered and inserts in only one direction into the slot. Secure with the socket head screw provided.

2.1.2 Use the cap screw provided to attach the mounting bracket to the light mount. Secure with the lock nut provided.

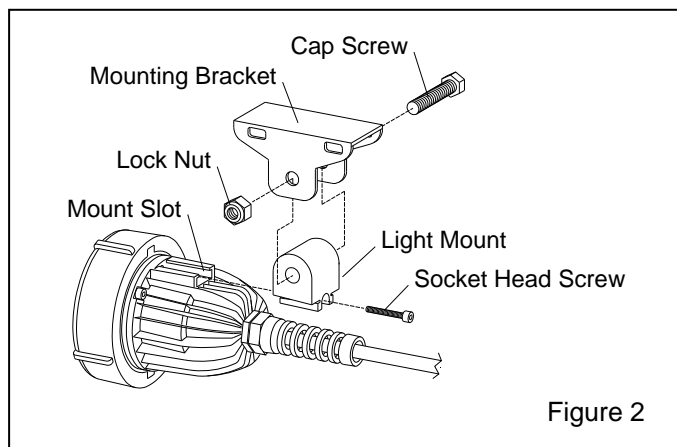

Figure 2

2.2 Assemble Light to Blast Hose Refer to Figure 3

2.2.1 Use cable ties provided or user-supplied worm clamps to attach the light to the blast hose, nozzle holder or nozzle, as shown in Figure 3. When attaching the light to a slick surface, such as a nozzle or nozzle holder, use adhesive-backed gasket to prevent the light from

slipping. To apply cut two lengths of gasket long enough to wrap around the holder; remove the backing and apply the gasket around the holder, spaced so one length of gasket is centered under each slot in the mounting bracket, as shown in Figure 3.

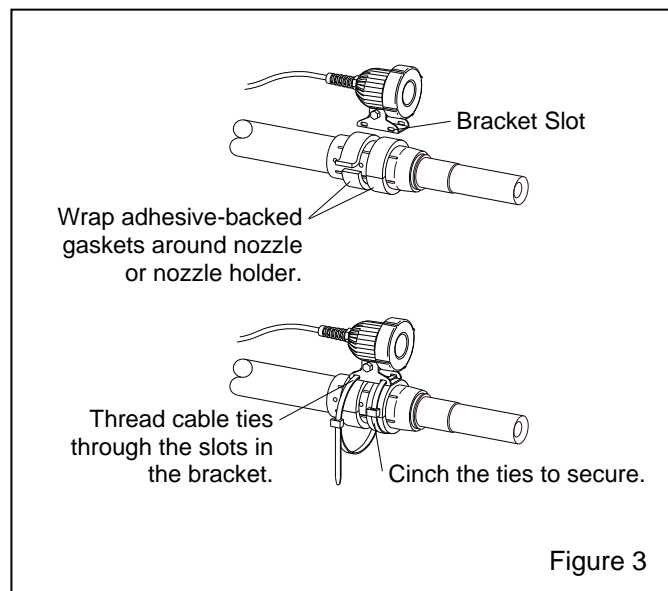

Figure 3

2.2.2 Thread the cable ties through the mounting bracket slots, as shown in Figure 3, and loosely secure enough to barely hold the light in position.

2.2.3 Make sure the light is aligned with the nozzle; the pivot adjustment will be done later. If the light is attached to the hose, and it is too far from the nozzle, bends in the hose will direct the blast stream away from the light beam.

2.2.4 Make sure the light and cable are placed so they do not interfere with the operation of the control handle or operator's grip on the blast hose.

⚠ WARNING

When attaching the light to the blast hose, make sure it does not restrict operation of the control handle or reduce the grip on the blast hose. Any interference with the operation of the control handle or grip on the blast hose may cause a condition which could result in injury from the blast stream.

2.2.5 Cinch the cable ties to securely fix the light. Once the light is firmly attached, clip the tie ends so they will not interfere with the operators grip or operation of the control handle.

2.2.6 Loosely wrap the power supply cable around the end of the blast hose and attach cable ties or tape. The cable needs to be attached with enough slack to prevent the cable from being stretched taut when the blast hose is moved or pulled.

NOTICE

Make sure there is enough slack in the cable to prevent the cable from being stretched taut when the blast hose is moved or pulled. Damage could occur at the wire connections if the cable is stretched taut.

2.2.7 When used in permanent blast installations, it may be helpful to strap the cable to the blast hose every three or four feet. When used in portable applications, the cable may be kept loose and always detachable from the blast hose to prevent damage to the light when coiling the hose and moving to another worksite.

2.3 Connect Cable to Power Supply

2.3.1 Connect the cable to a suitable 120-VAC or 12-VDC power supply. The light is on as soon as it is connected to a power source. NOTE for 12-VDC units only: The red (+) cable clamp must connect to the positive (+) terminal; if reversed, the light will not work.

3.0 ADJUSTMENTS

⚠ WARNING

Reposition the light and power cable as needed to avoid entanglement or other interference with the operation of the control handle or grip on the blast hose that may result in a condition causing injury from the blast stream.

3.1 Light Position on Hose

NOTE: If the light is used around structural parts, a variety of blast angles or any other application that may require frequent repositioning of the light, use reusable worm clamps to secure the light instead of cable ties.

3.1.1 Loosen clamps and rotate the light on the hose to provide the best lighting to the blast surface without interfering with the operation of the control handle or the grip on the blast hose.

3.2 Light Angle

3.2.1 Loosen the nut on the mounting bracket bolt and tilt the light as required to direct the light beam to provide best lighting to the blast area. Tighten the nut to maintain the setting.

4.0 OPERATION

4.1 Blasting Angle

4.1.1 Whenever possible, avoid blasting 90 degrees to the surface, as rebounding abrasive could rapidly etch the glass outer lens. Blast at 85 degrees or less.

5.0 MAINTENANCE

NOTICE

If the outer glass protective lens breaks, stop blasting immediately and replace it. Delaying replacement of a broken lens will quickly frost the inner poly lens. Continued usage with a broken outer lens could contaminate internal parts and require extensive cleaning and service. Prolonged use of the light with a broken outer lens could permanently damage internal parts of the light.

5.1 Cleaning and Replacing the Outer Protective Glass Lens, refer to Figure 4

5.1.1 The lens retainer attaches to the light assembly with a bayonet-style connection. Lens replacement is easier when the retainer is facing up. To remove the retainer from the light, twist it counterclockwise as viewed from the retainer end. If the retainer cannot be turned by hand, refer to Paragraph 5.1.2.

The lens and o-ring are loose; do not drop or misplace them. Both are included in the outer lens service kit.

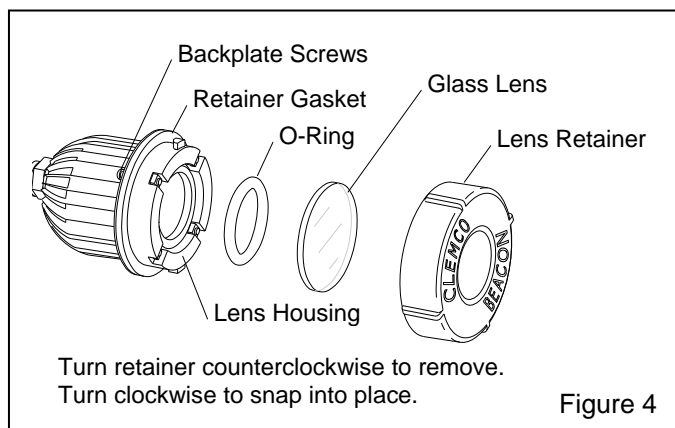

Figure 4

5.1.2 If the retainer cannot be turned, loosen the four backplate screws several turns to remove compression from the retainer gasket, then remove retainer. Note: when the gasket is compressed as noted in Paragraph 5.1.6, friction against the gasket may prevent the retainer from turning; loosening the backplate screws decompresses the gasket.

5.1.3 Clean the inner surface of the retainer, inner lens, and lens housing.

5.1.4 Discard the frosted lens and inspect the o-ring. Replace the o-ring if it is compressed or damaged.

5.1.5 Inspect the inner poly lens; if replacement is required, proceed to Section 5.2. If no other service is needed, reassemble as follows.

5.1.6 Place the o-ring in the recess on the lens housing, center a new lens on the o-ring. Reattach the retainer by aligning the grooves in the retainer with the tabs on the lens housing, turn the retainer clockwise to snap it in place.

5.1.7 Tighten the four backplate screws enough to compress the retainer gasket against the retainer, but not so tight as to prevent retainer removal by hand. Note: compressing the gasket assures a dust-tight seal between the retainer and light assembly.

5.2 Removing and Servicing the Inner Poly Lens and Lens Housing, refer to Figure 5

NOTE: The lens housing must be removed to access any serviceable items within the light assembly. Service is easier if the light assembly is removed from the blast hose, one suggestion is to remove the cap screw and lock nut from the mounting bracket as shown in Figure 2.

Note: The inner lens service kit include all items shown with an asterisk in Figure 5. The following instructions assume all the service kit items will be replaced.

5.2.1 Remove the lens retainer and glass outer lens, per Section 5.1.

5.2.2 Remove the four backplate screws, backplates, retainer gasket, and nuts.

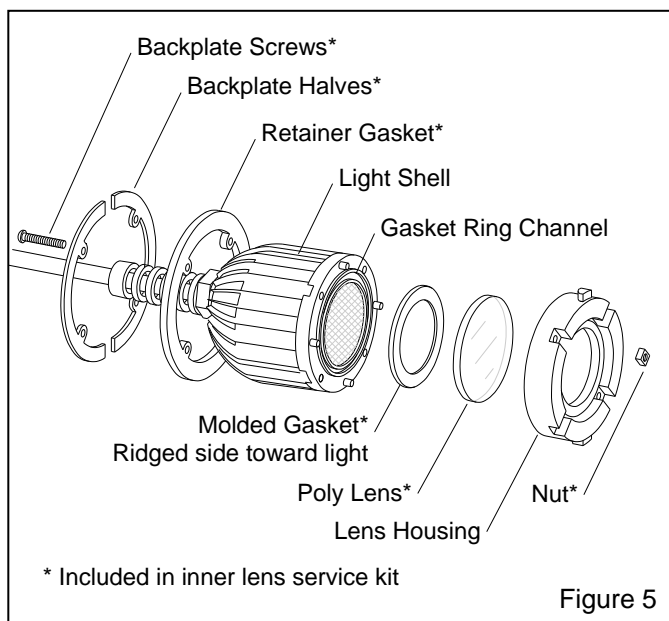

Figure 5

5.2.3 Remove the lens housing from the light assembly. NOTE: The lens housing is held to the light shell by friction. Pull the housing to remove it from the shell; cup the housing when removing it to catch the inner lens, it is loose within the housing.

5.2.4 Remove the gasket.

5.2.5 Clean all parts to be reused.

5.3 Reassemble Inner Lens and Housing to Light Assembly

5.3.1 Place the ridged side of the molded gasket into the channel on the light shell.

5.3.2 Make sure the nut cutouts in the lens housing are facing away from the light shell, and then set the poly lens into the housing recess.

5.3.3 Align the screw holes in the light shell with the cutouts in the housing. The locating nubs on the light shell align with the matting holes on the lens housing. Press the housing onto the shell to hold in place.

5.3.4 Insert the four backplate screws through the two backplate halves, gasket, light shell, and lens housing.

5.3.5 Place a square nut into the cutouts on the housing and tighten each backplate screw enough to engage the nuts. Note: A lip on the cutouts aligns the nut with the screw hole.

5.3.6 Place the o-ring in the recess on the lens housing, center a new lens on the o-ring. Reattach the retainer by aligning the grooves in the retainer with the tabs on the lens housing, turn the retainer clockwise to snap it in place.

5.3.7 Tighten the four backplate screws enough to compress the retainer gasket against the retainer, but not so tight as to prevent retainer removal by hand. Note: compressing the gasket assures a dust tight seal between the retainer and light assembly.

5.4 12-Volt Clamp Replacement

5.4.1 If clamps are removed for replacement or if the cable is connected to the power source by another method, make sure the white wire goes to positive (+) and the black wire goes to negative (-). The light will not operate if reversed.

5.5 Periodic Inspections.

5.5.1 Weekly

5.5.1.1 Check compression on the outer lens retainer gasket. Tighten the screws or replace the gasket as necessary to maintain a tight seal.

5.5.1.2 Inspect the inner lens; if it is dirty or otherwise needs service, refer to Section 5.2.

6.0 TROUBLESHOOTING

6.1 LED fails to illuminate when attached to power supply

6.1.1 Check power supply with volt meter to verify power.

6.1.2 Inspect cable; look for a cut, break, or other damage.

6.1.3 12-Volt operation

- Make sure red clamp is connected to the positive (+) terminal and the black clamp is connected to the negative (-) terminal.
- Inspect clamps and cable for corrosion.
- Make sure clamps firmly clamp to battery or power source.
- If certain the power supply is good and the clamps are making good contact, the cable or light assembly is faulty. The light assembly with cable is not serviceable, replace it.

6.1.4 120-Volt operation

- Inspect plug for damage.
- Remove conduit cover and apply power. Use a volt meter to make sure power is on the AC side of the LED driver. If no power, the 4-ft. supply cord is damaged; replace it.
- Use a volt meter to check power on the DC side of the LED driver.
 - If there is no power, the driver is faulty; replace it.
 - If there is power, the cable or light assembly is faulty. The light assembly with cable is not serviceable; replace it.

7.0 REPLACEMENT PARTS

7.1 Beacon Blast Light Assemblies

Description	Stock No.
12-VDC blast light with 50-ft cable	27740
12-VDC blast light with 100-ft cable	27741
120-VAC blast light with 50-ft cable	27742
120-VAC blast light with 100-ft cable	27743

7.2 Service Kits

Quantities shown in parentheses ()

7.2.1 Glass outer lens kit, Figure 6 28163

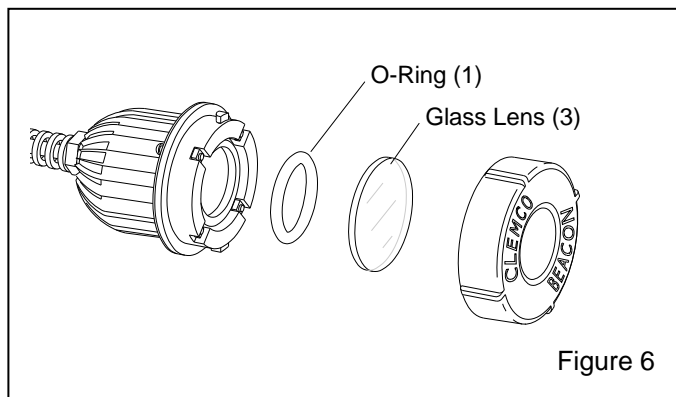

7.2.2 Poly inner lens kit, Figure 7 28164

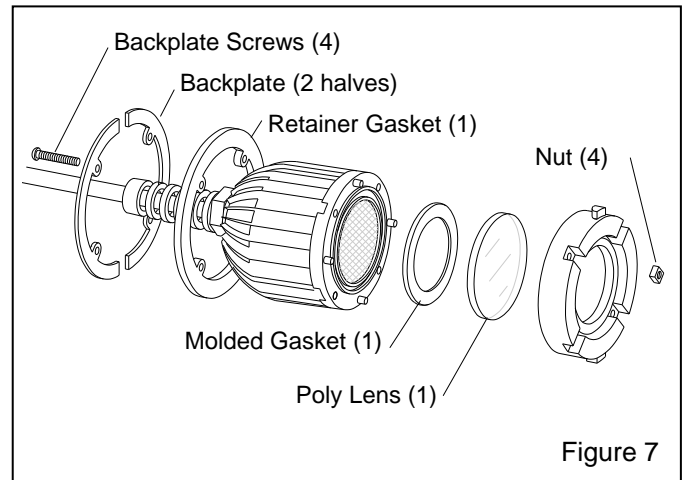

7.3 Blast Light Replacement Parts, Figure 8

Item	Description	Stock No.
1.	Retainer, outer lens	27748
2.	Bracket, mounting	27751
3.	Mount, light	28161
4.	Screw, light mount	28162
5.	Diffuser	28160
6.	Screw, 1/4-NC x 1.5" hex head cap	03055
7.	Nut, 1/4-NC lock	03112
8.	Tie, 14.5" long nylon	02195
9.	Gasket, 5/16" x 1" adhesive-backed per foot, specify feet required	00187
10.*	Driver, 120-V to 12-V LED	27758
11.*	Strain relief, 3/4-NPT x 1/4" cable	27756
12.*	Strain relief, 3/4-NPT x 3/8"- 5/8" cable ..	27757
13.*	Cord, 4-ft 120-v power	27766
14.**	Clamp set, 12-volt battery	27763
15.	Service kit, glass outer lens	28163
16.	Service kit, poly inner lens	28164

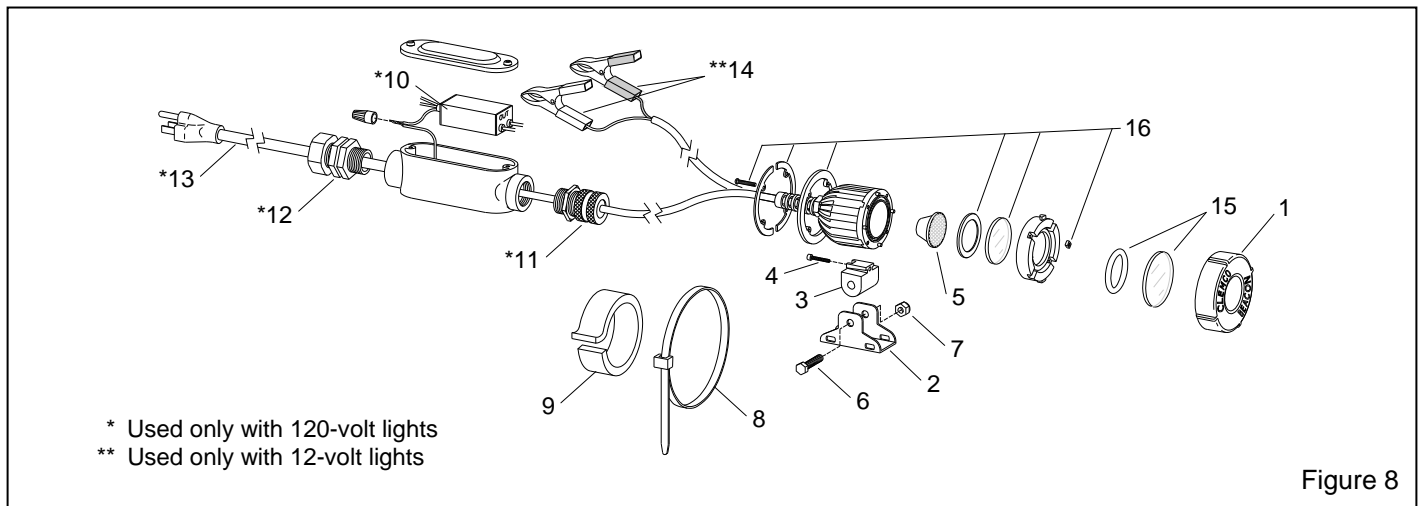

* Used only with 120-volt lights
 ** Used only with 12-volt lights