

Belt Sander

300BL/K

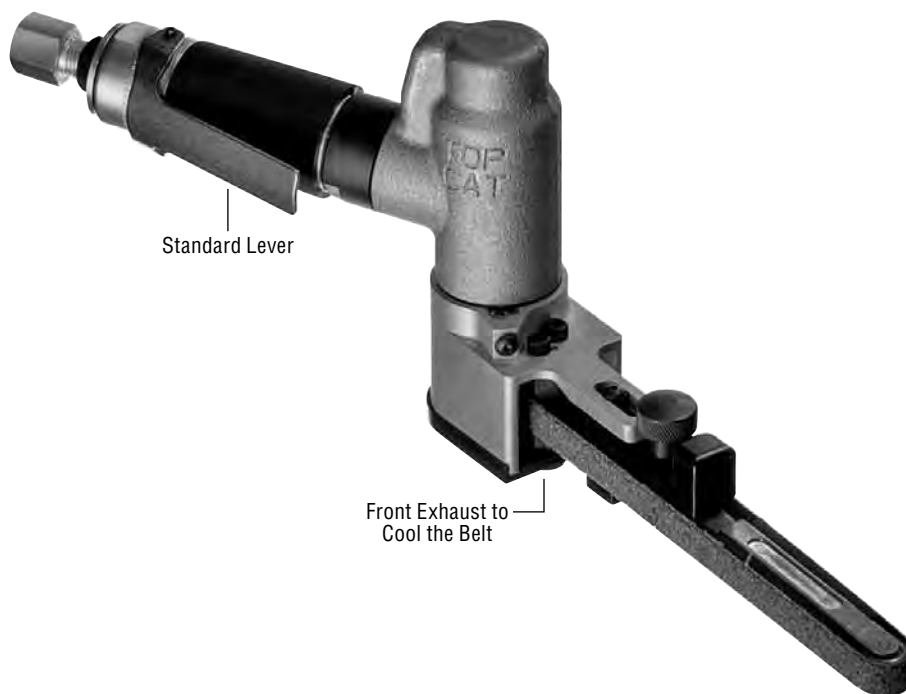

| Belt Capacity | Max. SFPM | Lever Style | Model Number |
|---------------------------|-----------|----------------|--------------|
| 5/8 or 3/4 Inch X 18 Inch | 5700 SFPM | Standard Lever | 300BL |
| | | Safety Lever | 300BK |

The 300B Series is offered in a version with a 4550 Max SFPM.

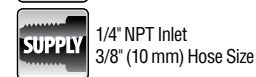
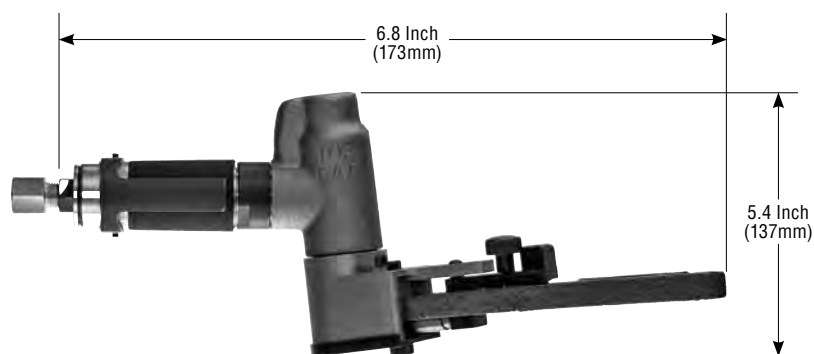

STANDARD EQUIPMENT

- Tool
- Operating Instructions and Service Manual
- Wrenches (sizes based on options)