

NORTON

WELDING AND METAL FABRICATION MARKET

EFFECTIVE 2013

STOCK ABRASIVE PRODUCTS



THE **MUSCLE** BEHIND THE MACHINE®



TM



TABLE OF CONTENTS





BONDED ABRASIVE PRODUCTS			COATED ABRASIVE PRODUCTS			NON-WOVEN PRODUCTS		
	Depressed Center Wheels	6		Fiber Discs	44		Right Angle Discs	140
	Small Diameter Cut-Off Wheels	17		Flap Discs	52		Discs	144
	High Speed Cut-Off Wheels	24		Paper Discs	61		Hand Pads, Rolls and Sponges	152
	Walk-Behind Cut-Off Wheels	26		Cloth PSA Discs	72		Surface Stripping, Unified, and Convolute Wheels	154
	Chop Saw Cut-Off Wheels	27		Quick-Change Discs	75		Belts	162
	Stationary Saw Cut-Off Wheels	30		Paper Sheets and Rolls	88		Flap Wheels	164
	Portable Snagging Wheels, Cones, and Plugs	31		Cloth Sheets and Rolls	95	NON-ABRASIVE PRODUCTS		
	Bench & Pedestal Wheels	34		Abrasive Sponges	97			
	Mounted Points	36		File Belts	99		Cloth Wipes, Polishing Pads, Masking Tape	172
	Rubbing Bricks	41		Portable Belts	103	GENERAL INFORMATION		
	Sharpening Stones	42		Narrow Belts	105			
				NORaX Belts	111	Coated Abrasive Basics	174	
				FastTrack Belts	112	Product Specification Key	175	
				Flap Wheels, Sand-O-Flex Wheels	114	Safety Guidelines	176	
				Specialties	125	Wheel Speed Conversion Table	181	
						Merchandising System	182	
						Contact Information	183	





THE **MUSCLE** BEHIND THE MACHINE.™

MACHINE INDEX

RIGHT ANGLE/VERTICAL SHAFT PORTABLE GRINDERS

	Depressed Center Grinding Wheels, Notchers, 6-16 Saucers and Type 29 Wheels
	Right Angle Grinder Reinforced Cut-off Wheels, . . . 21-22 Type O1 and Type 27
	Coated Abrasive Fiber Discs 44-51
	Coated Abrasive Flap Discs 52-60
	Coated Abrasive Paper Discs 61-71
	Coated Abrasive Cloth PSA Discs 72
	Coated Abrasive Quick-Change Discs 75-87
	Non-Woven Depressed Center Wheels 140-142
	Non-Woven Discs 143-150
	Non-Woven Abrasive Brushes 151
	Wire Brushes 170

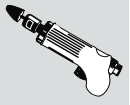
HORIZONTAL/STRAIGHT SHAFT PORTABLE GRINDERS

	Small Diameter Reinforced Cut-off Wheels (1-1/2"-6" wheels) 17-20
	Cones and Plugs 31, 33
	Snagging Straight Wheels 31-32
	Mounted Points 36-40
	Coated Abrasive Large Diameter Flap Wheels (3-1/2"-5" wheels) 121
	Non-Woven Unified Wheels 154-157
	Non-Woven Flap Wheels 164-165
	Wire Brushes 170

RIGHT ANGLE/VERTICAL SHAFT PORTABLE CUP GRINDERS

	Snagging Cup Wheels 31-32
	Wire Cup Brushes 168-169

PORTABLE CIRCULAR SAWS

	Circular Saw Reinforced Cut-off Wheels 23
---	---

HAND-HELD GAS AND ELECTRIC SAWS

	High Speed Reinforced Cut-off Wheels 24-25
---	--

WALK-BEHIND SAWS

	Reinforced Cut-off Wheels 26
	Wire Brushes 170

CHOP SAWS

	Chop Saw Reinforced Cut-off Wheels 27-29
---	--

STATIONARY CHOP STROKE MACHINES

	Large Diameter Reinforced Cut-off Wheels 30
---	---



FLEXIBLE SHAFT MOTORS

	Non-Woven Surface Stripping Wheels 154-155
	Non-Woven Unified Wheels 154-157

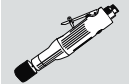

DRILLS

	Small Diameter Reinforced Cut-off Wheels 17-20 (2" and 3" wheels with mandrel)
	Coated Abrasive Small Diameter Flap Wheels . . . 114-120
	Sand-O-Flex Wheels 124
	Non-Woven Surface Stripping & Unified Wheels 154-157

DIE AND PENCIL GRINDERS

	Mounted Points 36-40
	Coated Abrasive Small Diameter Flap Wheels . . . 114-120
	Coated Abrasive Specialties 125-137
	Non-Woven Flap Wheels (2"-4" wheels) 164-165
	Non-Woven Surface Stripping and 154-157 Unified Wheels (1"-4" wheels)
	Wire Brushes 170-171

BENCH AND PEDESTAL GRINDERS

	Vitrified Bench and Pedestal Wheels 34-35
	Coated Abrasive Large Diameter Flap Wheels . . . 121-123
	Sand-O-Flex Wheels 124
	Non-Woven Discs (6"-12" discs) 150
	Non-Woven Unified Wheels (6" wheels) 154-157
	Non-Woven Convolute Wheels (6"-14" wheels) . . . 158-161
	Non-Woven Flap Wheels (6"-8" wheels) 164-165
	Wire Brushes 169

ORBITAL SANDERS

	Coated Abrasive Paper Discs 61-71
	Coated Abrasive Small Diameter Cloth 73
	PSA Discs (5"-6" discs)

STATIONARY DISC SANDERS

	Coated Abrasive Large Diameter Cloth 74
	PSA Discs (10"-24" discs)

PORTABLE FILE BELT MACHINES

	Coated Abrasive Portable File Belts 99-102, 111
	Non-Woven File Belts 162-163

PORTABLE BELT SANDERS

	Coated Abrasive Portable Belts 103-104
	Non-Woven Portable Belts 162-163

IN-LINE DRUM SANDERS

	Coated Abrasive Portable Belts 103-104
	Non-Woven Portable Belts 162-163

BENCHSTAND GRINDERS

	Coated Abrasive Benchstand Belts . . . 105-110, 112-113
	Non-Woven Benchstand Belts 162-163

BACKSTAND BELT GRINDERS

	Coated Abrasive Backstand Belts 105-106, 110, 112-113
	Non-Woven Backstand Belts 162-163

JITTERBUG SANDERS

	Coated Abrasive Sheets and Rolls 88-96
	Non-Woven Rolls 152-153

HAND FINISHING APPLICATIONS

	Rubbing Bricks and Sharpening Stones 41-43
	Coated Abrasive Paper Discs 71
	Coated Abrasive Sheets, Rolls and Sponges 88-98
	Non-Woven Hand Pads, Rolls and Sponges 152-153
	Wire Brushes 171
	Micro-Fiber Cloths and Polishing Pads 172
	Masking Tape 173

SANDING BOARDS

	Sanding Boards and Coated Abrasive File Strips 92
---	---

FLAP DISCS MACHINES USED  C

CATEGORY DEFINITION A

Flap discs are versatile grinding and finishing tools, consisting of three main components: a backing plate, adhesive, and abrasive cloth flaps. The rectangular flaps are overlapped and glued to the backing plate. Flap discs are designed for right angle grinder applications ranging from heavy stock removal to surface blending.

APPLICATIONS: Grinding, stock removal, edge chamfering/beveling, weld blending, deburring/deflashing, rust removal, blending, cleaning and finishing

SIZE RANGE: 4"-5/8" hole

GRIT RANGE: 4-1/2" - 7": 5/8"-11 discard mount and 7/8" hole 24 - 120

ABRASIVE GRAIN: Ceramic Alumina, Zirconia Alumina, Aluminum Oxide, Silicon Carbide

ABRASIVE FLAPS: Polyester or cotton

FLAP DISC SHAPE: Type 27 Flat and Type 29 Conical

ABRASIVE FLAP DENSITY: Standard or high

BACKING PLATE MATERIAL: Fiberglass, plastic or aluminum

FLAP DISC SHAPES

Type 27 Flat – The Best Choice for Finishing

- Used primarily on flat surfaces
- The best choice for blending and smooth finishing

GRIND AT FLATTER ANGLES: 0° - 15°

Type 29 Conical – The Best Choice for Aggressive Stock Removal

- Conical flap discs have angled flaps and may be used on both contoured and edge work
- The angle provides greater surface contact for stock removal on flat surfaces
- The best choice when speed and stock removal are primary considerations

GRIND AT STEEPER ANGLES: 15° - 25°

ABRASIVE FLAP DENSITIES

Standard Density

- Excellent for heavy-duty applications and rapid stock removal

High Density

- Ideal when working on uneven or curved surfaces, as well as finer grit blending

BACKING PLATE MATERIALS

All flap discs are a combination of abrasive flaps adhered to a rigid backing plate. It is the backing plate that provides stability during operation. There are three main materials used: fiberglass, plastic or aluminum. The fiberglass backing plate, along with the flap shape, helps to absorb vibration and is consumed during use with no smearing. Fiberglass is the most popular material because of its high strength and light weight. The plastic backing plate offers some additional conformability and is trimmable. The aluminum backing plate provides extra high strength and rigid support as needed. While not consumable during use, an aluminum plate can be recycled.

BACKING PLATE

WHY CHOOSE FLAP DISCS? E

Flap discs replace both grinding wheels and fiber discs. The same flap disc can be used for applications that require both grinding and finishing.

Flap Discs vs. Grinding Wheels

- Faster stock removal
- Smoother finish, no gouging
- Cooler cutting, less glazing
- Lightweight, easier to control
- Less vibration, less operator fatigue
- Reduced noise

Flap Discs vs. Fiber Discs

- 20X longer
- Fewer discs
- More consistent
- No back-up
- Easier storage
- Reduced tool changeover
- Use flap discs

54 **NORTON – THE MUSCLE BEHIND THE MACHINE™**

Easy to Follow Page Guide
Key Questions to Simplify Product Selection

Am I in the Right Section?

- A** Product category overview
- B** General attributes
- C** Correct machine use

How Do I Narrow my Choices?

- D** Product design variations
- E** Like product comparisons

How Do I Match My End-User Needs?

- F** Application recommendations
- G** Best / Better / Good performance color coding
- H** Full application / grit guide

How Do I Match or Upgrade from a Competitive Product?

- I** Cross reference guide

FLAP DISCS MACHINE USED 

MATERIAL-TO-PRODUCT RECOMMENDATION GUIDE F

	BEST Highest Productivity – Lowest Total Cost	BETTER Excellent Blend of Performance & Price	GOOD Consistent Performance – Lowest Total Cost
Type 29 for Stock Removal			
Stainless Steel / Titanium / Super Alloys	Norton Blaze R980P	Norton BlueFire R884P	Merit Metal
Mild Carbon Steel / Welds	Norton Red Heat R961	Norton BlueFire R884P	Merit Metal
Ferrous Metals / Cast Iron	Norton Red Heat R961	Norton BlueFire R884P	Merit Metal
Brass / Bronze / Aluminum	–	Norton BlueFire R884P	Merit Silicon Carbide
Paint / Glue / Adhesive	–	–	Merit Silicon Carbide
Concrete / Stone / Fiberglass	–	–	Merit Silicon Carbide
Type 27 for Blending and Finishing			
Stainless Steel / Titanium / Super Alloys	Norton Blaze R980P	Norton BlueFire R884P	Merit Metal
Mild Carbon Steel / Welds	Norton Red Heat R961	Norton BlueFire R884P	Merit Metal
Ferrous Metals / Cast Iron	Norton Red Heat R961	Norton BlueFire R884P	Merit Metal
Brass / Bronze / Aluminum	–	Norton BlueFire R884P	Merit Metal

APPLICATION/GRIT RECOMMENDATION GUIDE H

COARSER (GRINDING) FINER (FINISHING)

GRIT: 24 36 40 50 60 80 100 120

HEAVY STOCK REMOVAL | EDGE CHAMFERING/BEVELING WELD BLENDING | DEBURRING/DEFLASHING RUST REMOVAL/BLENDING | CLEANING AND FINISHING

STANDARD DENSITY HIGH DENSITY

CROSS REFERENCE GUIDE I

	TOTAL PERFORMANCE		INITIAL PRICE		SPECIALTY
	BEST	BETTER	GOOD		
NORTON	Blaze R980P	Red Heat R961	BlueFire R884P	Merit R756	
MERIT	–	–	–	Metal / Zirconia Silicon Carbide	
3M	947D	747D	563D, 546D	–	
DeWalt	–	–	–	Z/A	
Camel	–	C3	Z-Stainless	Z3, A3 SC	
Flexovit	–	–	–	Zircotex Premium, Zircotex HP	
Garryson	–	–	Zirc+, Zirconium	Aluminum Oxide	
GemTex	–	Ceramic	–	Zirconia, A/O	
Hermes	–	–	–	–	
Klingspor	–	–	SMT 630	SMT 618, 619, 624, 626, 627, 628, 640	
Metabo	–	–	–	Z/A	
Pearl	–	Stainless Max	Zirconia Premium, TuffMax	Z/A Silver Line, Premium A/O Classic, SC Silver Line	
Pferd	–	Ceramic	Cool Zirconia, CO-COOL	Zirconia, Cool Aluminum Oxide, Aluminum Oxide	
Salt	–	–	Z	2A, 3A	
SIA	–	–	–	Z/A	
Standard	–	Ceramic Oxide	Zirconia Pro	Zirconia	
Tyrolit	–	–	Z/A	A/O	
Walter	–	–	Enduro Flex	–	
Weller	–	Saber Tooth Ceramic	–	Tiger Zirconium, A/O, Vortec	

www.nortonabrasives.com 55



What are the Leading Products by Tier?

- J** Features and benefits
- K** New and/or improved
- L** Unique and/or innovative

FLAP DISCS

MACHINES USED



FEATURED PRODUCTS

J



NORTON BLAZE R980P
BEST/HIGHEST PRODUCTIVITY FOR STAINLESS STEEL, TITANIUM, AND SUPER ALLOYS

FEATURES	BENEFITS
<ul style="list-style-type: none"> ■ Latest-generation ceramic alumina abrasive grain ■ Supersize grinding aid ■ Y-weight polyester flaps ■ Durable fiberglass back ■ Orange, flexible plastic backing plate on Type 27 Quick Trim 	<ul style="list-style-type: none"> ■ Last 50% – 200% longer than any flap discs on stainless steel, cobalt, chrome, Inconel, titanium and other hard-to-grind materials ■ Cool, noticeably fast cut rate ■ Significantly improve life, grain retention and fray resistance ■ High strength, lightweight, absorbs vibration ■ New industry standard for trimmability

K



NORTON RED HEAT R961
BEST/HIGH PRODUCTIVITY FOR MILD CARBON STEEL, AND FERROUS METALS

FEATURES	BENEFITS
<ul style="list-style-type: none"> ■ New, premium ceramic and zirconia alumina abrasive blend ■ Durable, fiberglass back (Type 29) ■ Red, flexible plastic backing plate on Type 27 Quick Trim 	<ul style="list-style-type: none"> ■ Excellent performance and efficiencies on mild carbon steel and ferrous metal/cast iron applications ■ High strength, lightweight, absorbs vibration ■ New industry standard for trimmability

K



NORTON BLUEFIRE R884P
BETTER CHOICE FOR MILD CARBON STEEL, AND WELD

FEATURES	BENEFITS
<ul style="list-style-type: none"> ■ High performance zirconia alumina plus abrasive ■ Polyester flaps ■ Semi-open coat ■ Durable, fiberglass back ■ Blue, flexible plastic backing plate on Type 27 Quick Trim 	<ul style="list-style-type: none"> ■ Aggressive cut and long life ■ Up to 30% longer life than competitive zirconia alumina products ■ Improved durability ■ Retards loading on aluminum ■ High strength, lightweight, absorbs vibration ■ New industry standard for trimmability

K



NORTON NEON R766
GOOD CHOICE FOR ALUMINUM, BRASS, BRONZE, STAINLESS, CARBON STEEL, AND TITANIUM

FEATURES	BENEFITS
<ul style="list-style-type: none"> ■ Alternating aluminum oxide (green) and zirconia alumina (blue) flaps ■ New resin system and Y-wt. polyester flaps ■ New grain coating ■ Type 29, Type 27 HD; fiberglass back 	<ul style="list-style-type: none"> ■ Ideal when purchasing criteria is a good-performing, economically-priced, general purpose disc ■ Improved base adhesion and 30%+ improvement in life over key competitors' aluminum oxide flap discs ■ Stand up on light- to moderately-demanding applications ■ Longer life and faster cut rate ■ High strength, lightweight, absorb vibration ■ New industry standard for trimmability

FLAP DISCS

MACHINE USED



AVAILABILITY

M



TIER	BRAND	TRADE NAME	SHAPE	FLAP DENSITY	ABRASIVE	BACKING PLATE	OTHER
M	Norton	BLAZE R980P	Type 27 Flat	Standard	Ceramic Alumina	Quick Trim Plastic	Supersize
N	Norton	BLAZE R980P	Type 27 Flat	High	Ceramic Alumina	Fiberglass	Supersize
O	Norton	BLAZE R980P	Type 29 Conical	Standard	Ceramic Alumina	Quick Trim Plastic	Supersize
	Norton	RED HEAT R961	Type 27 Flat	Standard	Ceramic Alumina/Zirconia Alumina	Quick Trim Plastic	Supersize
	Norton	RED HEAT R961	Type 29 Conical	Standard	Ceramic Alumina/Zirconia Alumina	Fiberglass	Supersize

SIZE (D x H)	GBIT	MAX. RPM	STD. PKG	PART NO.	PART NO.	PART NO.	PART NO.	PART NO.
4 x 5/8	40	15,300	10				63642536153	
	60					63642536154		
	80					63642536155		
5/8-11	36	13,300	10		6625449894	66261183490	66623399163	66623399003
	40			66254400257	66261183491	63642536147	63642536156	
	60			66254400258	66261183492	63642536148	63642536157	
	80			66254400259	66261183493	63642536149	63642536158	
	120			66254400261		66623399164	63642597115	
4-1/2 x 7/8	36	13,300	10		66261097678	66261183486	63642504876	63642504329
	40			66254400253	66261183487	63642504877	63642504330	
	60			66254400254	66261183488	63642504878	63642504331	
	80			66254400255	66261183489	63642504879	63642504332	
	120			66254400256		63642505279	63642504333	
5 x 5/8-11	40	12,000	5				66623399165	66623399197
	60					66254491941	66623399198	
	80					66254491942	66623399199	
	120					66254491943	66623399200	
						66623399166	66623399201	
5 x 7/8	36	12,000	10		66261190001	63642505281	66623399054	
	40			66254400262	63642505282	66623399055		
	60			66254400264	63642505283	66623399056		
	80			66254400265	63642505284	66623399057		
	120			66254400519	63642505285	66623399058		
6 x 5/8-11	40	10,200	5				66623399167	
	60					66623399168		
	80					66623399169		
	120					66623399202		
						66623399204	63642541406	
6 x 7/8	40	10,200	10				66623399205	63642541407
	60					66623399206	63642541408	
	80					66623399207		
	120					66623399207		
						66623399208	63642541409	
7 x 5/8-11	36	8,600	10		66261183498	66623399170	66623399058	
	40			66254461066	63642536150	63642536159		
	60			66254461067	63642536151	63642536160		
	80			66254461068	63642536152	63642536161		
	120			66254461069	66623399171	66623399203		
7 x 7/8	36	8,600	10		66261183494	63642504880	63642504334	
	40			66254461059	63642504881	63642504335		
	60			66254461060	63642504882	63642504336		
	80			66254461061	63642504883	63642504337		
	120			66254461063	66623399172	63642504338		

* 5/8-11 (HUBBED) RED HEAT FLAP DISC STD. PKG. QUANTITY = 5

L



New Trimmable, Flexible Plastic Backing Plate

Quick Trim Blaze R980P and Red Heat R961

New higher-performance abrasive flaps are mounted on our new flexible, easily-trimmable plastic backing plate. To fully use the flaps, the new Quick Trim flap discs are the answer. Available in 7/8" hole or our industry standard 5/8-11 mini mount that ensures maximum safety for all right angle grinders.

How Do I Find What I Want now that I Know What I Want?

- M** Visual identification
- N** Key product attributes
- O** Full specification and product number





NORTON
SAINT-GOBAIN
NORZON
PLUS

NORTON
SAINT-GOBAIN
BLUEfire™

NORTON
SAINT-GOBAIN
GEMINI®



CATEGORY DEFINITION

Depressed center wheels may also be referred to as raised hub wheels or by their shape designation of “Type”, with Type 27 being the most popular. The depressed center design allows the flange/lock nut to recess within the wheel so that it can be used for various grinding and cutting applications. Depressed center wheels are designed to handle the most severe right angle grinding applications from heavy stock removal to rough blending. More recently, depressed center wheels have been designed to increase the utility of the tool for cut-off applications. While large right angle grinders (7" & 9") have been around for many years, small or mini grinders that handle 4", 4-1/2" and 5" wheels have made this machine, and wheel category, the most popular in power tools.

- APPLICATIONS:** Grinding, stock removal, edge chamfering, beveling, weld blending, and cutting-off
- SIZE RANGE:** 2" – 9"
- THICKNESS RANGE:** .040 (1/32) – .250 (1/4")
- GRIT RANGE:** 24 – 46 grits for stock removal; 60, 80, 120 grits for blending and finishing
- ABRASIVE GRAIN:** Ceramic Alumina, Zirconia Alumina, Aluminum Oxide, Silicon Carbide
- MOUNTING OPTIONS:** Plain hole (5/8" and 7/8") and discard mount (5/8"-11 and 3/8"-24)
- SHAPE:** Type 27, Type 28, Type 29

TYPE-TO-APPLICATION RECOMMENDATION GUIDE

WHEEL TYPE/THICKNESS	APPLICATIONS		
TYPE 27 	Type 27 wheels are essentially straight wheels that have a “depressed center/raised hub”. Different types of fiberglass reinforcement mesh give the product stability for use on the periphery, on the face, or a combination of the two.	 90° ANGLE	 30° ANGLE
.040", .045", .060", and .090" Type 27/42 RightCut	Cutting only, where fast cutting and low kerf loss are desired	■	
.090" Type 27/42 RightCut	For tough cutting and notching applications where stability is important	■	
.125" Type 27/42 RightCut	Cutting and cleaning burr-free narrow root pass welds	■	
1/8" Type 27	For multiple applications ranging from cutting-off, notching and light-duty side grinding	■	■
5/32" Type 27	2-1/2 pieces of reinforcement; durable face grinding; root pass grinding without removing pipe material	■	■
1/8" Type 27 Flexible	For light stock/blending/finishing/polishing	■	
1/8" Type 27 Foundry Notchers	Triple-reinforced for grinding steel and dirty/scale-covered castings; removing and cleaning gates and risers	■	■
1/4" Type 27	For heavy-duty to light grinding on the bottom/face of the wheel		■
1/4" Type 27 Foundry Snaggers	Designed for cleaning parting lines, pads and slag		■
1/4" Type 27 Heavy-Duty Foundry	Triple-reinforced for the most aggressive foundry applications		■
TYPE 28 	Type 28 wheels are constructed with a downward angle built into the grinding section to facilitate a flatter grinding angle. These wheels can only be used on the face and never on the periphery for cutting-off.		 15° ANGLE
1/4" Type 28 Saucers	Smooth, gouge-free grinding at shallow angles		■
TYPE 29 	Type 29 wheels are constructed with an upward angle built into the grinding section to provide full face contact for light stock removal and blending operations. These wheels can only be used on the face and never on the periphery for cutting-off.		 15° ANGLE
1/8" Type 29 Flexible, AVOS	Polishing and blending applications		■



MATERIAL/APPLICATION-TO-PRODUCT RECOMMENDATION GUIDE

	BEST HIGHEST PRODUCTIVITY LOWEST TOTAL COST	BETTER EXCELLENT BLEND OF PERFORMANCE & PRICE	GOOD CONSISTENT PERFORMANCE LOW INITIAL PRICE
Cutting			
Mild Carbon / High Tensile Steel	Norton NorZon Plus	Norton BlueFire	Norton Metal
Stainless Steel / Alloys	Norton NorZon Plus	Norton BlueFire	Norton Gemini
Contaminate Free		Norton BlueFire INOX	Norton Gemini INOX
Cast Iron	Norton NorZon Plus	Norton BlueFire	Norton Gemini
Gray Iron		Norton BlueFire Foundry	
Aluminum / Bronze / Brass			Norton Gemini Aluminum
Asphalt / Brick / Concrete			Norton Masonry
Fiberglass / Plastic			Norton Masonry
Notching			
Mild Carbon / High Tensile Steel	Norton NorZon Plus	Norton BlueFire	Norton Metal
Stainless Steel / Alloys	Norton NorZon Plus	Norton BlueFire	Norton Gemini
Contaminate Free		Norton BlueFire INOX	Norton Gemini INOX
Cast Iron	Norton NorZon Plus	Norton BlueFire	Norton Gemini
Grinding			
Mild Carbon / High Tensile Steel	Norton NorZon Plus	Norton BlueFire	Norton Metal
Stainless Steel / Alloys	Norton NorZon Plus	Norton BlueFire	Norton Gemini
Contaminate Free		Norton BlueFire INOX	Norton Gemini INOX
Cast Iron	Norton NorZon Plus	Norton BlueFire	Norton Gemini
Gray Iron	Norton NorZon Plus Foundry	Norton BlueFire Foundry	Norton Gemini
Aluminum / Bronze / Brass			Norton Gemini Aluminum
Asphalt / Brick / Concrete			Norton Masonry
Blending			
Mild Carbon / High Tensile Steel			Norton Gemini Flexible
Stainless Steel / Alloys			Norton Gemini Flexible
Aluminum / Bronze / Brass			Norton Gemini Flexible
Fiberglass / Plastic			Norton Gemini Flexible

TYPICAL STEEL, STAINLESS STEEL, CAST IRON PRODUCTS: ANGLE IRON, BAR STOCK, DUCTILE PIPE, CHANNEL IRON, DECKING, REBAR, I-BEAMS, RAIL STEEL, STUDS, TUBING, AND WELDS

HOW TO PICK THE RIGHT BOND TYPE

Standard	Unmarked	Where an excellent blend of cut rate and life is needed
Fast Cut	FC	Where fast stock removal is needed, or the application only allows for low-pressure or under-horsepowered grinders
Long Life	LL	Where durability is needed due to severe application, and when horsepower of the grinder allows for heavy pressure
Contaminate Free	INOX	Contain <0.1% iron, sulfur or chlorine for rust-free and corrosion-free results. Will not contaminate stainless steel

HOW TO PICK THE RIGHT MOUNT

Most wheel sizes come with a plain hole or a discard mount option. While the plain hole has a small, initial cost advantage, the discard mount can provide a labor cost advantage with the quicker wheel change.

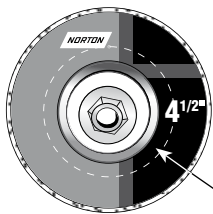

Mini-Mount Hub

Our unique, patented mini-mount hub used on 4-1/2" and 5" depressed center wheels provides up to 30% more wheel life because the hub covers just a small surface area, providing maximum grinding area exposure and usage.

STANDARD THROW-AWAY HUB SIZE

WHY CHOOSE DEPRESSED CENTER WHEELS?

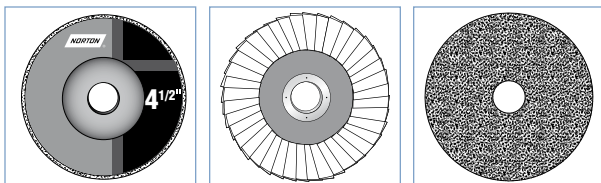

Depressed Center Wheels vs. Flap Discs or Fiber Discs

- Up to 5X life over flap discs, less downtime
- Up to 100X life over fiber discs, less downtime
- Rigidity for severe operations and high power grinders
- 1/8" wheels can be used for cutting and grinding
- Can be used to grind inside corners at outer edge of wheel



CROSS REFERENCE GUIDES

TYPE 27/42 RIGHTCUT – .040" - .125"

TOTAL PERFORMANCE

INITIAL PRICE

SPECIALTY

NORTON	BEST		BETTER			GOOD			GOOD	
	NorZon Plus	NorZon Plus	BlueFire	BlueFire	BlueFire	Gemini INOX	Gemini Long Life	Gemini		Metal
Brilliant	—	—	—	—	—	—	Brill-Blade Heavy Duty	Brill-Blade Extra FC	Hornet	—
Bullard	—	—	ZA60T	—	—	—	TA46T, TA60T TA60U	SGA60U	A46T, A60T Comp.	AL46N
Camel	—	—	ZA Quickie Cut	—	—	A60-T-BF, WA60R Quickie Cut	Super Quickie Cut	A36-S-BF	—	A46 Quickie Cut
Flexovit	—	—	—	—	—	—	Razorblade A60SST	Razorblade A24T, 30V, 36T	—	—
Pearl	—	—	Redline Max Slimcut	—	—	—	Slimcut	—	Slimcut Pro-V, Silverline	—
Pferd	—	—	SGP-ZA-Q-INOX	—	—	SG-A-R-INOX, SGP-A-S-INOX	SG-A-S, SGP-A-T	—	PSF-A-P	S-G-N-ALU
Sait	Saitech	—	Z-tech	—	—	XA46R	A60S	SAIT.M.X	—	A46N
SpedeCut	—	—	—	—	—	—	—	—	A46, 60 TBXX	—
Walter	—	—	—	—	—	A-60SS-ZIP	A-60-ZIP	A-30-ZIP	—	A-60-ZIP-ALU

TYPE 27 AND 28 – 1/8" AND 1/4"

TOTAL PERFORMANCE

INITIAL PRICE

SPECIALTY

NORTON	BEST		BETTER			GOOD				GOOD	
	NorZon Plus	NorZon Plus Long Life	BlueFire INOX	BlueFire	BlueFire Foundry	Gemini	Gemini Fast Cut	Gemini INOX	Metal	Gemini Aluminum	Masonry
Brilliant	—	—	Brill-Max Z24R	—	—	Brill-TEX A24UHPXL, A30T	Brill-TEX A24R Super-G	Brill-TEX A30P	Hornet Metal	Brill-TEX 30ALU	Brill-TEX C30P, Hornet Concrete
Bullard	TA24S	—	ZA24R	ZA24R Competitor	—	A24R	A24N	A46Q	A24R Competitor	AL36N	C24R
Camel	—	—	ZA24T	—	—	A24R	Ultra A24-N-BF, A24T Super Quickie Cut	WA24S	A24N, R&T Fast Cut	A30N, Fast Cut	C24R
Flexovit	Flexon ZA20Q	Flexon ZA24P ZA30T	—	Metalhog AXT24S	Flexon ZA16U	High Performance A24/30T	High Performance A30S, Specialist A30Q & R	Free Grind A30Q	—	Specialist A24ALU	High Performance C24/30P
Metabo	—	—	ZA24T	—	—	A24R & T	A24N	A360	—	A36M	C24N
Pearl	—	—	Z24T	—	—	Premium Metal A24S, Redline Max A/WA24S	Premium Metal A24R, Redline Max A/WA24R	WA24R, SRT24	Silver Line A24R & S	D.A. Series AL24M	Silver Line C24S
Pferd	—	—	ZA R SGP, Z-SG	ZA S GP, ZA T SGP	—	A-PS, A-SG	—	A-SG INOX, A-PS INOX	—	A-SG ALU	S-SG, Masonry
Sait	Saitech Attacker, Pipeline	Saitech Ultimate Performance	Z24R Z-tech	—	CA24R - Foundry	A24R, A24 Turbo	A24N	XA24Q	—	A46N - Aluminum	C24N
Tyrolit	—	—	ZA24N-BFX	ZA24P-BFX	ZZA24R-BFX	A30S & Q-BFX	A30R-BFX	A30-BF INOX	A30-BF	A36N-BFX WA46-BF	C30-BF
Walter	—	—	Double-X, Allsteel	Allsteel XX	—	HP	—	Stainless	—	Aluminum	Concrete

TYPE 27 – FLEXIBLE 1/8"

NORTON	GOOD Gemini Flex
Brilliant	Brill-Flex
Bullard	Flexlite AC
Camel	FGF, Special Wheel
Flexovit	Flexcel
Metabo	Z-Plus
Pearl	Flexible AC
Pferd	SG-Flex
Sait	Challenger II
Walter	Flexcut



FEATURED PRODUCTS



NORTON NORZON PLUS

BEST/HIGHEST PRODUCTIVITY FOR STEEL, STAINLESS STEEL AND ALL OTHER FERROUS METALS

FEATURES

- Combination of patented and NorZon (zirconia alumina) with an advanced bond system
- Foundry Snagger

BENEFITS

- 50 to 200% better overall performance versus competitive zirconia Norton SG (ceramic alumina) and ceramic wheels
- Lowest total grinding cost; highest productivity
- Up to 10X the performance of aluminum oxide wheels
- 50% or better cut rate than competitive zirconia wheels
- Easy on the operator and equipment
- Designed to withstand the most aggressive foundry application



NEW

NORTON BLUEFIRE

BETTER CHOICE FOR STAINLESS STEEL, CARBON STEEL, ALLOYS AND GRAY IRON

FEATURES

- A blend of R&D advanced chemistry and shape zirconia alumina abrasive with premium aluminum oxide grain
- Contaminate-free BlueFire FastCut/*INOX*
- BlueFire Foundry

BENEFITS

- 2-3 times the life of aluminum oxide wheels
- Up to 20% increase in performance and life over our former zirconia alumina wheels
- Broad utility from light-to heavy-pressure applications, on a wide range of materials
- Excellent performance-to-price ratio for lower total grinding costs
- Contain <0.1% iron, sulfur, or chlorine for rust-free and corrosion-free results; will not contaminate stainless steel
- Zirconia alumina/silicon carbide abrasive blend and an exceptionally strong reinforcement structure
- The ideal choice for aggressive, foundry applications



NORTON GEMINI

GOOD CHOICE FOR STEEL AND FERROUS METALS AS WELL AS SPECIALTY APPLICATIONS IN ALUMINUM AND FOUNDRIES

FEATURES

- Quality aluminum oxide
- Gemini Contaminate Free *INOX*
- Gemini Aluminum

BENEFITS

- Consistent performance at a competitive price
- Contain <0.1% iron, sulphur or chlorine for rust-free and corrosion-free results; will not contaminate stainless steel
- Grind aluminum and soft metals without loading
- Contain no wax or rubber fillers



NORTON METAL/MASONRY

GOOD CHOICE FOR STEEL/FERROUS METAL AND MASONRY APPLICATIONS WITH LOW INITIAL PRICE

FEATURES

- Competitive initial price point
- Metal – aluminum oxide
- Masonry – sharp silicon carbide

BENEFITS

- Best starting specification for end user unable to measure performance
- Engineered for all steel/ferrous materials
- Engineered for all masonry materials such as concrete, brick and asphalt

Norton Fine, Hard Back Depressed Center Wheels Boost Productivity and Wheel Life

Versus Competitors' Monolithic Design (2 coarse layers)

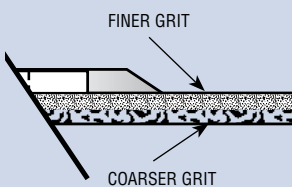

Our fine, hard back (a finer-grit mixture in the top half of the grinding wheel) limits premature shedding or “spalling” and allows for a smoother grinding action from the periphery to the hub.

- At the proper grinding angle, a sharp bevel is produced at the wheel periphery
- As the wheel wears, this thin edge become susceptible to stress
- A coarse grit back is much more likely to break away prematurely resulting in unnecessary wheel loss and quite possibly an injury to operator and others



AVAILABILITY



TIER:	BEST	BETTER	GOOD	GOOD
TRADENAME:	NORTON NORZON PLUS	NORTON BLUEFIRE	NORTON GEMINI	NORTON METAL
SHAPE:	Type 27/42	Type 27/42	Type 27/42	Type 27/42
ABRASIVE:	Ceramic Alumina/ Zirconia Alumina	Zirconia Alumina/ Aluminum Oxide	Aluminum Oxide	Aluminum Oxide
MATERIAL:	STAINLESS STEEL/METAL	STAINLESS STEEL/METAL	STAINLESS STEEL/METAL	STAINLESS STEEL/METAL

SIZE (D x T x H)	MAX. RPM	STD. PKG.	PART NO.	PART NO.	PART NO	PART NO
.040, .045, .060, .090, .125 – RightCut Cut-off – Type 27/42						
4 x .045 x 5/8	15,280	25			66252842180	07660705249
4 x .125 x 3/8	15,280	25	66252842001			
4-1/2 x .040 x 5/8-11	13,580	10		66252843227		
4-1/2 x .045 x 5/8-11	13,580	10	66252842006	66252843223	66252842025	
		10			66252841913 INOX	
4-1/2 x .045 x 7/8	13,580	25	66252843320	66252843219	66252842026	66252843604
		25			66252841912 INOX	
		25*			66252842161 5-Pk	
4-1/2 x .090 x 5/8-11	13,580	10			66252841903	
		10			66252842027 INOX	
4-1/2 x .090 x 7/8	13,580	25			66252841940	
		25			66252842028 INOX	
4-1/2 x .125 x 5/8-11	13,580	10	66252843321		66252843588	
4-1/2 x .125 x 7/8	13,580	25	66252843322		66252843589	
5 x .040 x 5/8-11	12,225	10		66252843228		
5 x .045 x 5/8-11	12,225	10			66252841939	
		10			66252841915 INOX	
5 x .045 x 7/8	12,225	25	66252843329	66252843220	66252842036	
		25			66252841914 INOX	
		25*			66252842171 5-Pk	
5 x .090 x 5/8-11	12,225	25			66252841904	
5 x .090 x 7/8	12,225	25			66252843587	
		25			66252842037 INOX	
5 x .125 x 7/8	12,225	25			66252843595	
6 x .045 x 5/8-11	10,185	10	66252842007		66252830587	
		10			66252841917 INOX	
6 x .045 x 7/8	10,185	25	66252842009	66252843221	66252842202	66252842015
		25			66252841916 INOX	
		25*			66252842176 5-Pk	
6 x .090 x 5/8-11	10,185	10			66252841905	
6 x .090 x 7/8	10,185	20			66252841906	
		20			66252832487 INOX	
6 x .125 x 5/8-11	10,185	10			66252841192	
6 x .125 x 7/8	10,185	25			66252842021	
7 x .045 x 5/8-11	8,600	10			66252841919 INOX	
7 x .045 x 7/8	8,600	20			66252841918 INOX	
7 x .060 x 7/8	8,600	20			66252912626	
		10				07660705251
7 x .125 x 5/8-11	8,600	10	66252912625			
7 x .125 x 7/8	8,600	20	66252912624		66252900619	
7 x .090 x 5/8-11	8,600	10			66252841907	
7 x .090 x 7/8	8,600	20			66252841908	
					66252914638 INOX	
					66253019115	
9 x 1/16 x 5/8-11	6,600	10				
9 x .090 x 5/8-11	6,600	10		66252842378		
9 x .090 x 7/8	6,600	20		66252842343		

RIGHTCUT WHEELS ARE TO BE USED FOR CUTTING ONLY.

1/8" – Pipe Notching – Type 27						
7 x 1/8 x 5/8-11	8,600	10	66252939184			
9 x 1/8 x 5/8-11	6,600	10	66253049066			

PIPE NOTCHERS ARE TO BE USED FOR CUTTING/NOTCHING ONLY.

* 5-WHEEL JOB PACKS; WHEELS ARE PACKED 5 WHEELS/PACK, WITH 5 JOB PACKS/CARTON. ORDER PER EACH WHEEL IN STANDARD PACKAGE QUANTITIES OF 25. ORDER IN MULTIPLES OF 25.

DEPRESSED CENTER WHEEL DESCRIPTION CODES						
FC = FAST CUT	HD = HEAVY DUTY	INOX = CONTAMINANT FREE	LL = LONG LIFE	1-2-3 = CUTTING/NOTCHING/GRINDING	BLANK = ALL PURPOSE	
■ = ALUMINUM	■ = FOUNDRY	■ = MASONRY	■ = STAINLESS	■ = STEEL / METAL		



AVAILABILITY



TIER:	BEST	BETTER	GOOD	GOOD
TRADENAME:	NORTON NORZON PLUS	NORTON BLUEFIRE	NORTON GEMINI	NORTON METAL
SHAPE:	Type 27 and Type 28	Type 27 and Type 28	Type 27 and Type 28	Type 27
ABRASIVE:	Ceramic Alumina/ Zirconia Alumina	Zirconia Alumina/ Aluminum Oxide	Aluminum Oxide	Aluminum Oxide
MATERIAL:	STAINLESS STEEL/METAL	STAINLESS STEEL/METAL	STAINLESS STEEL/METAL	STAINLESS STEEL/METAL

SIZE (D x T x H)	MAX. RPM	STD. PKG.	PART NO	PART NO	PART NO	PART NO
3/32", 1/16", 1/8", 5/32" – Cutting / Notching / Light Grinding – Type 27						
3 x 1/8 x 3/8	18,000	25	66252842177			
4 x 1/8 x 3/8	15,280	25	66252842004	66252843178	66252843178	
4 x 1/8 x 5/8	15,280	25	66252842005	66252843176	66252842017	66252842014
4-1/2 x 3/32 x 5/8-11	13,580	25			66252841903	
		10			66252842027 INOX	
4-1/2 x 3/32 x 7/8	13,580	25			66252841940	
		25			66252842028 INOX	
		25			66252843582 1-2-3	
4-1/2 x 1/8 x 5/8-11	13,580	10	66252843323	66252843211	66252843590	
		10		66252843191 FC		66252843609
		10‡			66252842166 2-Pk	
4-1/2 x 1/8 x 7/8	13,580	25	66252843324	66252843212	66252843591	66252843611
		25		66252843190 FC		
		10‡			66252842167 2-Pk	
5 x 3/32 x 5/8-11	12,225	25			66252841904	
5 x 3/32 x 7/8	12,225	25			66252842037 INOX	
					66252843587 LL	
					66252843583 1-2-3	
5 x 1/8 x 5/8-11	12,225	10	66252843330	66252843215		
		10		66252843195 FC		66252843615
5 x 1/8 x 7/8	12,225	25	66252843331	66252843216	66252843596	
		25		66252843194 FC		66252843616
5 x 5/32 x 7/8	13,580	25			66252842038	
6 x 3/32 x 5/8-11	10,185	10			66252841905	
6 x 3/32 x 7/8	10,185	10			66252841906	
					66252832487 INOX	
6 x 1/8 x 5/8-11	10,185	10	66252841891	66252843199 FC	66252833965	
6 x 1/8 x 7/8	10,185	20		66252843202	66252801864	
		20		66252843198 FC		
6 x 5/32 x 5/8-11	10,185	10			66252841193	
6 x 5/32 x 7/8	10,185	20			66252835580	
7 x 1/16 x 7/8	8,600	20			66252912626	
7 x 3/32 x 5/8-11	8,600	10			66252841907	
7 x 3/32 x 7/8	8,600	20			66252841908	
7 x 3/32 x 7/8	8,600	20			66252914638 INOX	
7 x 1/8 x 5/8-11	8,600	10	66252938855	66252843233	66252939259	07660702678
		10		66252843183 FC		
7 x 1/8 x 7/8	8,600	20	66252938854	66252843234	66252939207	
		20		66252843182 FC		
		25*				07660775956 5-Pk
7 x 5/32 x 7/8	8,600	20			66252835581	
9 x 1/8 x 5/8-11	6,600	10	66253048897	66252843244	66253048983	
		10		66252843187 FC		
9 x 1/16 x 5/8-11	6,600	10			66253019115	
9 x 1/8 x 7/8	6,600	20	66253048896	66252843245	66253048994	
		20		66252843186 FC		
9 x 1/4 x 7/8	6,600	20			66253049081	

* 5-WHEEL JOB PACKS: WHEELS ARE PACKED 5 WHEELS/PACK, WITH 5 JOB PACKS/CARTON. ORDER PER EACH WHEEL IN STANDARD PACKAGE QUANTITIES OF 25. ORDER IN MULTIPLES OF 25.
 ‡ 2-WHEEL SMALL PACKS (VENDIBLE/PEGGABLE); WHEELS ARE PACKED 2 WHEELS/PACK, WITH 5 PACKS/CARTON. ORDER PER EACH WHEEL IN STANDARD PACKAGE QUANTITIES OF 10.

DEPRESSED CENTER WHEEL DESCRIPTION CODES						
FC = FAST CUT	HD = HEAVY DUTY	INOX = CONTAMINANT FREE	LL = LONG LIFE	1-2-3 = CUTTING/NOTCHING/GRINDING	BLANK = ALL PURPOSE	
AL = ALUMINUM	FO = FOUNDRY	MA = MASONRY	SS = STAINLESS	SM = STEEL / METAL		



AVAILABILITY



TIER:	BEST	BETTER	GOOD	GOOD
TRADENAME:	NORTON NORZON PLUS	NORTON BLUEFIRE	NORTON GEMINI	NORTON METAL
SHAPE:	Type 27 and Type 28	Type 27 and Type 28	Type 27 and Type 28	Type 27
ABRASIVE:	Ceramic Alumina/ Zirconia Alumina	Zirconia Alumina/ Aluminum Oxide	Aluminum Oxide	Aluminum Oxide
MATERIAL:	STAINLESS STEEL/METAL	STAINLESS STEEL/METAL	STAINLESS STEEL/METAL	STAINLESS STEEL/METAL

SIZE (D x T x H)	MAX. RPM	STD. PKG.	PART NO	PART NO	PART NO	PART NO
1/4" – Grinding – Type 27						
3 x 1/4 x 3/8	18,000	25	66252842178		66252842179	
4 x 1/4 x 3/8	15,280	25	66252842002	66252843179	66252842018	
4 x 1/4 x 5/8	15,280	25	66252842003	66252843177	66252842020 FC	66252842011
		25			66252842019	
4-1/2 x 3/16 x 7/8	13,580	25	66252843325		66252843592	
4-1/2 x 1/4 x 5/8-11	13,580	10	66252843326	66252843213	66252843593	66252843605
		10	66252843327	66252843193 FC	66252843585 FC	
		10			66252842032 INOX	
		40				66252819559
		10‡	66252829541 2-Pk	66252842162 2-Pk	66252842163 2-Pk	
4-1/2 x 1/4 x 7/8	13,580	25	66252843328	66252843214	66252843594	66252843607
		25		66252843192 FC	66252843584 FC	
		25			66252842033 INOX	
		50				66252836796
		10‡	66252829540 2-Pk	66252842164 2-Pk	66252842165 2-Pk	
5 x 1/4 x 5/8-11	12,225	10	66252843332	66252843217	66252843597	66252843613
		10	66252843333 LL	66252843197 FC		
		25*				07660775913 5-Pk
5 x 1/4 x 7/8	12,225	25	66252843334	66252843218	66252843598	66252843614
		25		66252843196 FC	66252843586 FC	
		25			66252842040 INOX	
		10‡			66252842172 2-Pk	
6 x 1/4 x 5/8-11	10,185	10	66252841920	66252843224	66252832390	
		10		66252843201 FC		
6 x 1/4 x 7/8	10,185	20	66252809376	66252843203	66252801865	
		20		66252843200 FC		
7 x 1/4 x 5/8-11	8,600	10	66252917881	66252843235	66252940147 FC	66252912633
		10	66252835578 LL	66252843185 FC	66252940148 LL	
		25*				07660775940 5-Pk
7 x 1/4 x 7/8	8,600	20	66252917880	66252843236	66252940099 FC	
		20		66252843184 FC	66252940098 LL	
		25*				07660775936 5-Pk
9 x 1/4 x 5/8-11	6,600	10	66253021634	66252843246	66253049105 FC	
		10	66252830728 LL	66252843189 FC	66253049104 LL	
		25*				07660775938 5-Pk
9 x 1/4 x 7/8	6,600	20	66253021633	66252843247	66253049077 FC	
		20		66252843188 FC	66253048991 LL	
1/4" – Grinding – Type 28 Saucer						
7 x 1/4 x 5/8-11	8,600	10	66252905369	66252843229	66252940149	
7 x 1/4 x 7/8	8,600	20	66252905368		66252940095	
9 x 1/4 x 5/8-11	6,600	10	66253006335	66252843237	66253049106	
9 x 1/4 x 7/8	6,600	20			66253049081	

* 5-WHEEL JOB PACKS; WHEELS ARE PACKED 5 WHEELS/PACK, WITH 5 JOB PACKS/CARTON. ORDER PER EACH WHEEL IN STANDARD PACKAGE QUANTITIES OF 25. ORDER IN MULTIPLES OF 25.
 ‡ 2-WHEEL SMALL PACKS (VENDIBLE/PEGGABLE); WHEELS ARE PACKED 2 WHEELS/PACK, WITH 5 PACKS/CARTON. ORDER PER EACH WHEEL IN STANDARD PACKAGE QUANTITIES OF 10.

Small Pack Convenience

Looking for a package solution that is vendible and/or peggable, small pack products are ideal. Pre-packaged in convenient quantities for optimal coverage of popular applications and performance tier needs. Also ideal for supplying smaller customers where larger pack sizes would take longer to turn as well as test opportunities with larger volume end-users.

Wheels are packed 2 wheels per pack, with 5 packs per carton.





AVAILABILITY



TIER:	BEST	BEST	BETTER
TRADENAME:	NORTON NORZON PLUS	NORTON NORZON III	NORTON BLUEFIRE
SHAPE:	Type 27	Type 27	Type 27
ABRASIVE:	Ceramic Alumina/ Zirconia Alumina	Ceramic Alumina/ Zirconia Alumina	Zirconia Alumina/ Silicon Carbide
MATERIAL:	FOUNDRY	FOUNDRY	FOUNDRY

SIZE (D x T x H)	MAX. RPM	STD. PKG.	PART NO.	PART NO.	PART NO.
1/8", 1/4" – Grinding / Cutting – Type 27					
4 x 1/4 x 3/8	15,280	25			66252843181
4 x 1/4 x 5/8	15,280	25			66252843180
4-1/2 x 1/8 x 5/8-11	13,580	10			66252843206
4-1/2 x 1/8 x 7/8	13,580	25			66252843204
4-1/2 x 1/4 x 5/8-11	13,580	10			66252843207
4-1/2 x 1/4 x 7/8	13,580	25			66252843205
5 x 1/8 x 5/8-11	12,225	10			66252824510
5 x 1/4 x 5/8-11	12,225	20			66252824511
7 x 1/8 x 5/8-11	8,600	10			66252843232
7 x 1/8 x 7/8	8,600	20			66252915526
7 x 1/4 x 5/8-11	8,600	10			66252843231
7 x 1/4 x 7/8	8,600	20			66252843230
9 x 1/8 x 5/8-11	6,600	10			66252843240
9 x 1/8 x 7/8	6,600	20			66252843238
9 x 1/4 x 5/8-11	6,600	10	66253007014		66252843241
		10			66252843261 HD
9 x 1/4 x 7/8	6,600	20	66253007013	66253049069	66252843239
		20	66252832897 HD		66252843260 HD

AVAILABILITY



TIER:	GOOD
TRADENAME:	NORTON GEMINI
SHAPE:	Type 27
ABRASIVE:	Aluminum Oxide
MATERIAL:	ALUMINUM

SIZE (D x T x H)	MAX. RPM	STD. PKG.	GRIT	PART NO.
1/8", 1/4" – Grinding / Cutting / Blending – Type 27				
4-1/2 x .045 x 7/8	13,580	25	36	66252841909
4-1/2 x 1/8 x 5/8-11	13,580	10	46	66252842029
4-1/2 x 1/8 x 7/8	13,580	25	46	66252842030
4-1/2 x 1/4 x 5/8-11	13,580	10	46	66252842031
4-1/2 x 1/4 x 7/8	13,580	25	46	66252842034
5 x .045 x 7/8	12,225	25	36	66252841910
5 x 1/4 x 7/8	12,225	25	46	66252842039
6 x .045 x 7/8	10,185	25	36	66252841911
7 x 1/4 x 5/8-11	8,600	10	24	66252940514
		10	46	66252940515
7 x 1/4 x 7/8	8,600	20	24	66252940516
9 x 1/4 x 5/8-11	6,600	10	24	66253049045

AVAILABILITY



TIER:	GOOD
TRADENAME:	NORTON MASONRY
SHAPE:	Type 27
ABRASIVE:	Silicon Carbide
MATERIAL:	MASONRY

SIZE (D x T x H)	MAX. RPM	STD. PKG.	PART NO.
1/8", 1/4" – Grinding / Cutting – Type 27			
4 x 1/8 x 5/8	15,280A	25	66252842013
4 x 1/4 x 5/8	15,280	25	66252842010
4-1/2 x 1/8 x 7/8	13,580	25	66252843601
4-1/2 x 1/4 x 5/8-11	13,580	10	66252843599
4-1/2 x 1/4 x 7/8	13,580	25	66252843600
5 x 1/4 x 7/8	12,225	25	66252843602
7 x 1/4 x 5/8-11	8,600	5	07660775942
7 x 1/4 x 7/8	8,600	5	07660775946
9 x 1/4 x 5/8-11	6,600	5	07660775937

DEPRESSED CENTER WHEEL DESCRIPTION CODES

FC = FAST CUT	HD = HEAVY DUTY	INOX = CONTAMINANT FREE	LL = LONG LIFE	1-2-3 = CUTTING/NOTCHING/GRINDING	BLANK = ALL PURPOSE
AL = ALUMINUM	FO = FOUNDRY	MA = MASONRY	SS = STAINLESS	ST = STEEL / METAL	



AVAILABILITY



TIER:	BETTER	GOOD	GOOD
TRADENAME:	NORTON AVOS GEMINI	NORTON GEMINI FLEXIBLE	NORTON GEMINI FLEXIBLE
SHAPE:	Type 29	Type 27	Type 29
ABRASIVE:	Aluminum Oxide	Aluminum Oxide	Aluminum Oxide
MATERIAL:	ALUMINUM	ALUMINUM	ALUMINUM
	STEEL/METAL	STEEL/METAL	STEEL/METAL

SIZE (D x T x H)	MAX. RPM	STD. PKG.	GRIT	PART NO.	PART NO.	PART NO.
1/8", 1/4" Flexible – Blending – Type 27 and 29						
2 x 1/8 x 3/8	30,560	25	60		66252835632*	
		25	80		66252835633*	
		25	120		66252835634*	
4 x 1/8 x 5/8	15,280	25	36		66252842181#	
		25	60		66252842182#	
4 x 1/4 x 5/8	15,280	25	46		66252842183	
4-1/2 x 1/8 x 5/8-11	12,000	10	36	66252842208		66252842203
4-1/2 x 1/8 x 7/8	12,000	25	36	66252842209	66252842041#	66252842204
		25	46	66252842210		
		25	60	66252842211	66252842042#	
5 x 1/8 x 7/8	12,225	25	36	66252842212		66252842205
7 x 1/8 x 5/8-11	8,600	10	36		66252939024	66252917052
7 x 1/8 x 7/8	8,600	20	36		66252939028#	66252917051

*5 WHEELS PER DISPLAY PACK; 5 DISPLAY PACKS PER STANDARD PACKAGE.

USE WITH BACK PLATE. TWO BACK PLATES ARE INCLUDED IN EACH BOX OF 20 WHEELS.



Norton Depressed Center Adapter Kit

This reusable adapter kit contains everything you need to mount depressed center wheels and saucers with 7/8" center holes on to a portable right angle or vertical shaft grinders. Adapter hubs are threaded for mounting on to standard 5/8"-11 NCRH spindles.

KIT NO.	WHEEL DIAMETER	WHEEL THICKNESS	PART NO.	STD. PKG.
114	6" thru 9"	1/16" thru 1/4"	07660789275	1

DEPRESSED CENTER WHEEL DESCRIPTION CODES

FC = FAST CUT	HD = HEAVY DUTY	INOX = CONTAMINANT FREE	LL = LONG LIFE	1-2-3 = CUTTING/NOTCHING/GRINDING	BLANK = ALL PURPOSE
■ = ALUMINUM	■ = FOUNDRY	■ = MASONRY	■ = STAINLESS	■ = STEEL / METAL	

**SMALL DIAMETER
REINFORCED CUT-OFF WHEELS**



NORTON
SAINT-GOBAIN
NORZON
PLUS

NORTON
SAINT-GOBAIN
BLUEfireTM

NORTON
SAINT-GOBAIN
GEMINI[®]



CATEGORY DEFINITION

The Norton small diameter cut-off wheel line consists of Type 01/41 straight and Type 27/42 depressed center cut-off wheels from 1-1/2" to 9" diameters. These wheels come in ultra thin .035 for quick burn-free and burr-free cutting to .125" for more durable applications. All are reinforced for the demanding nature of portable cut-off.

APPLICATIONS:	Cutting sheet metal, cutting pipe, and metal plate dimensioning (metal fabrication)
SIZE RANGE:	1-1/2" - 9" diameter
THICKNESS RANGE:	.035, .040, .045, .060, .090, and .125
ABRASIVE GRAIN:	Ceramic Alumina/Zirconia Alumina, Zirconia Alumina/Aluminum Oxide, Aluminum Oxide, Silicon Carbide
SHAPE:	Type 01/41 Straight and Type 27/42 Depressed Center

TYPE-TO-APPLICATION RECOMMENDATION GUIDE

WHEEL TYPE/THICKNESS APPLICATIONS

TYPE 01/41

Type 01/41 cut-off wheels are designed for traditional cut-off applications. All are supplied with full fiberglass reinforcing.

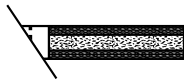

.035, .040, .045, .060	Where fast cutting and low kerf loss are desired	■	■
.090, .125	For tough cutting and notching applications where stability is important	■	■

TYPE 27/42

Type 27/42 cut-off wheels are designed with a depressed center to provide a recess for the hub, which allows flush cutting

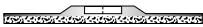

.040, .045, .060	Where fast cutting and low kerf loss are desired	■	■
.090, .125	For tough cutting and notching applications where stability is important	■	■

HOW TO PICK THE RIGHT BOND TYPE

All Purpose	Unmarked	Where an excellent blend of cut rate and life is needed
Free Cut	FC	Where fast stock removal is needed, or the application only allows for low-pressure or under-horsepowered grinders
Long Life	LL	Where durability is needed due to severe application, and when horsepower of the grinder allows for heavy pressure
Contaminate Free	INOX	Contain <0.1% iron, sulfur or chlorine for rust-free and corrosion-free results; will not contaminate stainless steel
Aluminum	ALU	Specially formulated bond for reduced loading/surface contamination cutting aluminum/soft materials
EVO	EVO	For severe cutting applications

MATERIAL-TO-PRODUCT RECOMMENDATION GUIDE

	BEST HIGHEST PRODUCTIVITY LOWEST TOTAL COST	BETTER EXCELLENT BLEND OF PERFORMANCE & PRICE	GOOD CONSISTENT PERFORMANCE LOW INITIAL PRICE
Cutting			
Mild Carbon / High Tensile Steel	Norton NorZon Plus	Norton BlueFire	Norton Metal
Stainless Steel / Alloys	Norton NorZon Plus	Norton BlueFire	Norton Gemini
Contaminate Free		Norton BlueFire INOX	Norton Gemini INOX
Cast Iron	Norton NorZon Plus	Norton BlueFire	Norton Gemini
Aluminum / Bronze / Brass			Norton Gemini ALU
Asphalt / Brick / Concrete			Norton Masonry



CROSS REFERENCE GUIDES

TYPE 01/41 .035 - .125 CUT-OFF WHEELS FOR DIE GRINDERS

	TOTAL PERFORMANCE			INITIAL PRICE		SPECIALTY	
	BEST NorZon Plus	BETTER BlueFire	GOOD Gemini Free Cut	Gemini	Metal	GOOD Gemini INOX	
Brilliant	—	Brill-Max ZA	—	—	Safe-Tex FC, LL	—	
Bullard	—	ZA46T, ZA60T	TA36T	TA46T, TA60T	A36T, A60T Comp.	—	
Camel	—	ZA60-TBF	A36 RBF	A60 RBF	Fast Cut RBF	—	
Flexovit	Flexon Fast Cut A46, 60	—	High Perf Fast Grind A36	High Perf Fast Cut A36, 46, 60	—	—	
Pearl	—	SRT, Zirconia	—	Premium	Silver Line	—	
Pferd	—	—	—	—	PSF-A	SG-A-R-INOX	
Sait	Saittech	—	A60S	A24R, A36T, A60T	—	—	
SpedeCut	—	—	—	—	A46, 60 TBXX	—	
Walter	—	—	A24 ZIP	A60 ZIP	—	—	

TYPE 01/41 AND TYPE 27/42 .040 - .125 CUT-OFF WHEELS FOR RIGHT ANGLE GRINDERS

	TOTAL PERFORMANCE				INITIAL PRICE			SPECIALTY		
	BEST NorZon Plus Fast Cut	NorZon Plus	BETTER BlueFire Fast Cut	BlueFire	GOOD Gemini Fast Cut	Gemini	Metal	GOOD Gemini ALU	Gemini INOX	Masonry
Brilliant	—	—	—	—	Brill-Blade Extra FC	Brill-Blade Heavy Duty	Hornet Stinger	—	—	—
Bullard	—	—	—	ZA60T	SGA60U	TA46T, TA60T, TA60U	A46T, A60T Comp.	AL46N	—	C24R
Camel	—	—	—	ZA Quickie Cut	A36-S-BF	Super Quickie Cut	Quickie Cut	A46 Quickie Cut	A60-T-BF, WA60R Quickie Cut	—
Flexovit	—	—	—	—	Razorblade A60SST	Razorblade A24T, 30V, 36T	—	Razorblade A30Q	—	C30U
Metabo	—	—	—	A 60 XP Super Slicer	—	A 60 TX Slicer-Plus	A 60 TZ Slicer	—	—	—
Pearl	—	—	—	Redline Max Slimcut	—	Slimcut	Slimcut Pro-V, Sliverline	—	—	—
Pferd	—	—	—	SGP-ZA-Q- INOX	—	SG-A-S, SGP-A-T	PSF-A-P	S-G-N-ALU	SG-A-R- INOX, SGP-A- S-INOX	SG-C-R
Sait	—	Saittech	—	Z-tech	SAIT.M.X	A60S	—	A46N	XA46R	—
SpedeCut	—	—	—	—	—	—	A46, 60 TBXX	—	—	—
Walter	—	—	—	—	A-30-ZIP	A-60-ZIP	—	A-60-ZIP-ALU	A60-SS-ZIP	C-30-ZIP

FEATURED PRODUCTS



NORTON NORZON PLUS CUT-OFF / RIGHTCUT

BEST CHOICE FOR HIGHEST PRODUCTIVITY FOR STEEL, STAINLESS STEEL AND ALL OTHER FERROUS METALS

FEATURES

- Patented Norton SG (ceramic alumina) / NorZon (zirconia alumina) grain combination
- Highly advanced bond system

BENEFITS

- Fastest cutting wheel available on the market, up to 3X faster cutting versus aluminum oxide
- 3X – 10X life versus aluminum oxide wheels on carbon steel, stainless and cast iron



NORTON BLUEFIRE CUT-OFF / RIGHTCUT

BETTER CHOICE FOR STAINLESS STEEL, CARBON STEEL, ALLOYS AND GRAY IRON

FEATURES

- A blend of R&D advanced chemistry and shape zirconia alumina abrasive with premium aluminum oxide grain
- Contaminate-free BlueFire FastCut/INOX

BENEFITS

- 2-3 times the life of aluminum oxide wheels
- Broad utility from light-to heavy-pressure applications
- Excellent performance-to-price ratio for lower total grinding costs
- Contain <0.1% iron, sulfur, or chlorine for rust-free and corrosion-free results; will not contaminate stainless steel

SMALL DIAMETER REINFORCED CUT-OFF

MACHINES USED

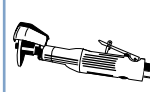

AVAILABILITY

TIER:

TRADENAME:

SHAPE:

ABRASIVE:

MATERIAL:



BEST

BETTER

BETTER

GOOD

GOOD

GOOD

NORTON NORZON PLUS

NORTON BLUEFIRE

NORTON A60-OBNA2

NORTON GEMINI

NORTON GEMINI LONG LIFE

NORTON METAL

Type 01/41

Type 01/41

Type 01/41

Type 01/41

Type 01/41

Type 01/41

Ceramic Alumina/
Zirconia Alumina

Zirconia Alumina/
Aluminum Oxide

Aluminum Oxide

Aluminum Oxide

Aluminum Oxide

Aluminum Oxide

STAINLESS

STAINLESS

STAINLESS

STAINLESS

STAINLESS

STAINLESS

STEEL/METAL

STEEL/METAL

STEEL/METAL

STEEL/METAL

STEEL/METAL

STEEL/METAL

SIZE (D x T x H)	MAX. RPM	STD. PKG.	PART NO.	PART NO.	PART NO.	PART NO.	PART NO.	PART NO.	PART NO.
Type 01/41 – Cut-off									
1-1/2 x .035 x 1/16	40,745	25			66243427764				
1-1/2 x .035 x 1/8	40,745	25			66243427831				
1-1/2 x .035 x 1/4	40,745	25			66243427875				
2 x .035 x 1/8	30,560	25				66243411392	FC		
2 x .035 x 1/4	30,560	25			66243428014	66243411393	FC		
2 x .035 x 3/8	30,560	25				66243411394	FC		
2 x .060 x 1/8	30,560	25			66243428041				
2 x .060 x 1/4	30,560	25			66243427993	66243411395	FC		
2 x .060 x 3/8	30,560	25				66243411396	FC		
2 x .125 x 1/4	30,560	25				66243411402	FC		
2 x .125 x 3/8	30,560	25				66243411403	FC		
2-1/2 x .035 x 1/8	30,560	25			66243528476				
2-1/2 x .035 x 1/4	30,560	25			66243528425				
2-1/2 x .060 x 1/4	30,560	25				66243510640	FC		
2-1/2 x .060 x 3/8	30,560	25				66243510641	FC		
2-7/8 x .035 x 1/4	25,465	25							07660789019
3 x .035 x 1/4	25,465	25	66243510668		66243528573	66243510627	FC		
	25,465	5	66243531753	5-Pk					
3 x .035 x 3/8	25,465	25	66243510669		66243528574	66243510628	FC	66243537271	LL
	25,465	5	66243534828	5-Pk	66243528574				07660789451
3 x .060 x 1/4	25,465	25	66243510670		66243528471	66243510645	FC	66243510649	LL
3 x .060 x 3/8	25,465	25	66243510671		66243528552	66243510647	FC	66243510648	LL
	25,465	25	66243510835	LL		66252835553			07660789012
	25,465	5							07660747767
	25,465	5							66252843624
	25,465	5							with Mandrel
3 x .125 x 1/4	25,465	25				66243510650	FC	66243510652	LL
3 x .125 x 3/8	25,465	25	66243510673			66243510651	FC	66243510653	LL
4 x .035 x 1/4	19,100	25			66243529606	66243510629	FC		07660789384
4 x .035 x 3/8	19,100	25	66243510675		66243529621	66243510630	FC	66243537273	LL
	19,100	25			66252843173	66252836496			07660789453
4 x .035 x 1/2	19,100	25			66243529622				
4 x .035 x 3/4	19,100	25			66243529609				
4 x .040 x 3/8	15,280	25			66243529516				
4 x .040 x 5/8	15,280	25							07660701616
4 x .045 x 5/8	15,280	25				66243527956			07660705249
4 x .060 x 1/4	19,100	25	66243510676			66243510654	FC		
4 x .060 x 3/8	19,100	25	66243510677		66252843171	66243510655	FC	66243510657	LL
4 x .060 x 5/8	19,100	25				66243527827		66243527826	LL
4 x .090 x 5/8	15,280	25				66243527955			
4 x .125 x 1/4	19,100	25				66243510658	FC		
4 x .125 x 3/8	19,100	25	66243510841		66252843172	66243510659	FC	66243510661	LL
	19,100	25	66243510680	LL					
5 x .035 x 3/8	12,225	25			66252830653				
6 x .035 x 3/8	10,185	25			66252835064				
6 x .035 x 1/2	10,185	25			66252835053				
6 x .035 x 5/8	10,185	25			66252835054	66252809714			
6 x .040 x 3/8	12,225	25							66252840608
6 x .060 x 5/8	10,185	25				66252809718			
7 x .060 x 5/8	8,600	25				66252905957			
8 x .060 x 5/8	7,640	25			66253017771	LL	66253007025		
		10					66253017795		
Drill Mount Mandrel		5							07660747769*

* FOR MOUNTING 2" AND 3" x 3/8" HOLE CUT-OFF WHEELS ON TO A DRILL

WHEEL DESCRIPTION CODES				
EVO = SEVERE CUTTING	FC = FAST CUT / FREE CUT	INOX = CONTAMINANT FREE	LL = LONG LIFE	BLANK = ALL PURPOSE
M = MASONRY	S = STAINLESS	ST = STEEL / METAL		



AVAILABILITY

TIER:	BEST	BETTER	GOOD	GOOD
TRADENAME:	NORTON NORZON PLUS RIGHTCUT	NORTON BLUEFIRE RIGHTCUT	NORTON GEMINI RIGHTCUT	NORTON METAL RIGHTCUT
SHAPE:	Type 01/41	Type 01/41	Type 01/41	Type 01/41
ABRASIVE:	Ceramic Alumina/ Zirconia Alumina	Zirconia Alumina/ Aluminum Oxide	Aluminum Oxide	Aluminum Oxide
MATERIAL:	STAINLESS STEEL/METAL	STAINLESS STEEL/METAL	STAINLESS STEEL/METAL	STAINLESS STEEL/METAL

SIZE (D x T x H)	MAX. RPM	STD. PKG.	PART NO.	PART NO.	PART NO.	PART NO.
Type 01/41 – RightCut Cut-off						
4 x .040 x 5/8	15,280	25				07660701616
4 x .045 x 5/8	15,280	25			66243527956	
4 x .090 x 5/8	15,280	25			66243527955	
4-1/2 x .040 x 7/8	13,580	25		66252843225		07660701617
	13,580	250•				66252840001 <i>Bulk</i>
	13,580	25*				66252842158 <i>5-Pk</i>
4-1/2 x .045 x 7/8	13,580	25	66252830730	66252843208	66252823602	
	13,580	25			66252841994 <i>ALU</i>	
	13,580	25			66252841997 <i>INOX</i>	
	13,580	25			66252832906 <i>EVO</i>	
	13,580	250•			66252841213 <i>Bulk</i>	
	13,580	250•			66252841216 <i>EVO Bulk</i>	
	13,580	25*		66252842159 <i>5-Pk</i>	66252842160 <i>5-Pk</i>	
4-1/2 x .090 x 7/8	13,580	25			66252823599	
5 x .040 x 7/8	12,225	25		66252843226		07660701618
	12,225	25*				66252842168 <i>5-Pk</i>
5 x .045 x 7/8	12,225	25	66252830731	66252843209	66252823603	
	12,225	25			66252841995 <i>ALU</i>	
	12,225	25			66252841998 <i>INOX</i>	
	12,225	25			66252832907 <i>EVO</i>	
	12,225	250•			66252841214 <i>Bulk</i>	
	12,225	250•			66252841217 <i>EVO Bulk</i>	
	12,225	25*		66252842169 <i>5-Pk</i>	66252842170 <i>5-Pk</i>	
5 x .050 x 7/8	12,225	25	66252809829			
5 x .090 x 7/8	12,225	25			66252823600	
6 x .040 x 3/8	12,225	25				66252840608
6 x .040 x 7/8	10,185	25				07660702757
	10,185	250•				66252841212 <i>Bulk</i>
	10,185	25*				66252842173 <i>5-Pk</i>
6 x .045 x 7/8	10,185	25	66252842008	66252843210	66252823604	
	10,185	25			66252841996 <i>ALU</i>	
	10,185	25			66252841999 <i>INOX</i>	
	10,185	25			66252832908 <i>EVO</i>	
	10,185	250•			66252841215 <i>Bulk</i>	
	10,185	25*		66252842174 <i>5-Pk</i>	66252842175 <i>5-Pk</i>	
6 x .090 x 7/8	10,185	25			66252823601	
7 x .045 x 7/8	8,600	25			66252842000 <i>INOX</i>	
7 x .060 x 5/8	8,600	25			66252905957	
7 x .060 x 7/8	8,600	25	66252900652		66252832323	

RIGHTCUT WHEELS ARE TO BE USED FOR CUTTING ONLY

* 5-WHEEL JOB PACKS: WHEELS ARE PACKED 5 WHEELS/PACK, WITH 5 JOB PACKS/CARTON. ORDER PER EACH WHEEL IN STANDARD PACKAGE QUANTITIES OF 25. ORDER IN MULTIPLES OF 25.
• BULK PACKED 250/CARTON; 5 INNER BOXES OF 50 WHEELS EACH. ORDER IN MULTIPLES OF 250 WHEELS.

Bulk Pack Quantities



Ideal for the larger end-user that needs stock on hand at all times or for the distributor who wants more wheels with lower initial purchase costs. Each master carton contains 5 inner boxes of 50 wheels per box.



AVAILABILITY



TIER:	BEST	BETTER	GOOD	GOOD
TRADENAME:	NORTON NORZON PLUS RIGHTCUT	NORTON BLUEFIRE RIGHTCUT	NORTON GEMINI RIGHTCUT	NORTON METAL RIGHTCUT
SHAPE:	Type 27/42	Type 27/42	Type 27/42	Type 27/42
ABRASIVE:	Ceramic Alumina/ Zirconia Alumina	Zirconia Alumina/ Aluminum Oxide	Aluminum Oxide	Aluminum Oxide
MATERIAL:	STAINLESS	STAINLESS	STAINLESS	STAINLESS
	STEEL/METAL	STEEL/METAL	STEEL/METAL	STEEL/METAL

SIZE (D x T x H)	MAX. RPM	STD. PKG.	PART NO.	PART NO.	PART NO.	PART NO.
Type 27/42 – RightCut Cut-off						
4 x .045 x 5/8	15,280	25			66252842180	07660705249
4 x .125 x 3/8	15,280	25	66252842001			
4-1/2 x .040 x 5/8-11	13,580	10		66252843227		
4-1/2 x .045 x 5/8-11	13,580	10	66252842006	66252843223	66252842025	
	13,580	10			66252841913 INOX	
4-1/2 x .045 x 7/8	13,580	25	66252843320	66252843219	66252842026	66252843604
	13,580	25			66252841912 INOX	
	13,580	25			66252841909 ALU	
	13,580	25*			66252842161 5-Pk	
4-1/2 x .090 x 5/8-11	13,580	10			66252841903	
	13,580	10			66252842027 INOX	
4-1/2 x .090 x 7/8	13,580	25			66252841940	
	13,580	25			66252842028 INOX	
4-1/2 x .125 x 5/8-11	13,580	10	66252843321		66252843588	
4-1/2 x .125 x 7/8	13,580	25	66252843322		66252843589	
5 x .040 x 5/8-11	12,225	10		66252843228		
5 x .045 x 5/8-11	12,225	10			66252841939	
	12,225	10			66252841915 INOX	
5 x .045 x 7/8	12,225	25	66252843329	66252843220	66252842036	
	12,225	25			66252841914 INOX	
	12,225	25			66252841910 ALU	
	12,225	25*			66252842171 5-Pk	
5 x .090 x 5/8-11	12,225	10			66252841904	
5 x .090 x 7/8	12,225	25			66252842037 INOX	
	12,225	25			66252843587	
5 x .125 x 7/8	12,225	25			66252843595	
6 x .045 x 5/8-11	10,185	10	66252842007		66252830587	
	10,185	10			66252841917 INOX	
6 x .045 x 7/8	10,185	25	66252842009	66252843221	66252842202	66252842015
	10,185	25			66252841916 INOX	
	10,185	25			66252841911 ALU	
	10,185	25*			66252842176 5-Pk	
6 x .090 x 5/8-11	10,185	10			66252841905	
6 x .090 x 7/8	10,185	20			66252841906	
	10,185	20			66252832487 INOX	
6 x .125 x 5/8-11	10,185	10			66252841192	
6 x .125 x 7/8	10,185	25			66252842021	
7 x .045 x 5/8-11	8,600	10			66252841919 INOX	
7 x .045 x 7/8	8,600	20			66252841918 INOX	
7 x .060 x 7/8	8,600	20			66252912626	07660705251
	8,600	10				
7 x .090 x 5/8-11	8,600	10			66252841907	
7 x .090 x 7/8	8,600	20			66252841908	
	8,600	20			66252914638 INOX	
7 x .125 x 5/8-11	8,600	10	66252912625			
7 x .125 x 7/8	8,600	20	66252912624		66252900619	
9 x .060 x 5/8-11	6,600	10			66253019115	
9 x .090 x 5/8-11	6,600	10		66252842378		
9 x .090 x 7/8	6,600	20		66252842343		

RIGHTCUT WHEELS ARE TO BE USED FOR CUTTING ONLY

* 5-WHEEL JOB PACKS; WHEELS ARE PACKED 5 WHEELS/PACK, WITH 5 JOB PACKS/CARTON. ORDER PER EACH WHEEL IN STANDARD PACKAGE QUANTITIES OF 25. ORDER IN MULTIPLES OF 25.

WHEEL DESCRIPTION CODES

EVO = SEVERE CUTTING	FC = FAST CUT / FREE CUT	INOX = CONTAMINANT FREE	LL = LONG LIFE	BLANK = ALL PURPOSE
■ = MASONRY	■ = STAINLESS	■ = STEEL / METAL		



AVAILABILITY



TIER:	BETTER	GOOD	GOOD	GOOD
TRADENAME:	NORTON CHARGER	NORTON GEMINI	NORTON METAL	NORTON MASONRY
SHAPE:	Type 01/41	Type 01/41	Type 01/41	Type 01/41
ABRASIVE:	Zirconia Alumina/ Aluminum Oxide	Aluminum Oxide	Aluminum Oxide	Silicon Carbide
MATERIAL:	STEEL/METAL	STEEL/METAL	STEEL/METAL	MASONRY
SIZE (D x T x H)	MAX. RPM	STD. PKG.	PART NO.	PART NO.

Type 01/41 – Circular Saw					
SIZE (D x T x H)	MAX. RPM	STD. PKG.	PART NO.	PART NO.	
6 x .035 x 5/8	10,185	25		66252809714	
6 x .060 x 5/8	10,185	25		66252809718	
6-1/2 x .125 x DM-5/8	9,405	10		07660789098	07660789089
7 x .060 x 5/8	8,730	25		66252905957	
7 x .125 x DM-5/8	8,730	25		07660789097	07660789088
8 x .060 x 5/8	7,640	25	66253017771 LL	66253007025	
		10		66253017795	
8 x 1/8 x DM-5/8	7,640	10		07660789096	07660789086

DM DENOTES DIAMOND MOUNT; 5/8" HOLE BUSHINGS INCLUDED

WHEEL DESCRIPTION CODES

EVO = SEVERE CUTTING	FC = FAST CUT / FREE CUT	INOX = CONTAMINANT FREE	LL = LONG LIFE	BLANK = ALL PURPOSE
■ = MASONRY	■ = STAINLESS	■ = STEEL / METAL		





CATEGORY DEFINITION

Norton high speed cut-off abrasive wheels provide the industry's leading performance in all high speed gas and electric-powered applications.

- APPLICATIONS:**
- Metalworking: steel, stainless, ductile, cast iron, rail steel and metal decking
 - Non-Metal Building Materials: concrete, brick, masonry, asphalt aggregate, stone and schedule 40 and 80 PVC pipe
 - Rescue and Demolition: steel, acrylic, fiberglass, rubber, glass, wood, concrete, brick and asphalt
- SIZE RANGE:** 12" – 16" diameter
- THICKNESS RANGE:** 1/8"
- ABRASIVE GRAIN:** Aluminum Oxide, Silicon Carbide
- SHAPE:** Type O1 Straight
- REINFORCEMENT:** Wheels are offered in standard two layer reinforcement as well as three layer reinforcement for higher speed saws and heavy-duty applications
- ARBOR:** Wheels are offered with a patent-pending universal arbor that accommodates both 20mm (Stihl®) and all other machines with 1" arbors

MATERIAL / APPLICATION-TO-PRODUCT RECOMMENDATION GUIDE

ICON		APPLICATION
	Metal	High-performance aluminum oxide grain wheels designed for general purpose cutting of all steel and stainless parts including rebar, steel pipe, structural steel, sheet metal, cable and small to medium diameter solid pieces.
	Metal Decking	High-performance aluminum oxide abrasive combined with a thicker wheel that stands up to the sharp edges of sheet metal and roof decking.
	Rail Steel	A finer grit, harder grade aluminum oxide wheel designed for straight, fast cuts on all sizes of rail track. Additional high-performance lines of rail cut wheels are available for production applications.
	Ductile/Cast Iron	A special blend of silicon carbide abrasive for cutting and aluminum oxide abrasive for life, designed to cut ductile and cast iron pipe, concrete-lined water pipes, sewer construction and heavy duty PVC.
	Rescue	For ventilation, forcible entry, rescue and demolition. A versatile abrasive formula that can be used on a wide range of materials including all types of metals and masonry.
	Concrete	Coarse grit silicon carbide abrasive provides a low initial cost solution for cutting brick, block, concrete or other masonry materials. For higher-production applications that require optimum speed of cut and product life, please see our complete selection of high speed diamond wheels in our Norton Construction diamond product line.
	Asphalt	A special blend of extra coarse silicon carbide abrasive grains provides a low initial cost solution for cutting asphalt, green concrete, asphalt over concrete, a wide range of aggregates and abrasive materials. For higher-production applications that require optimum speed of cut and product life, please see our Norton Construction diamond product line.

HOW TO PICK THE RIGHT REINFORCEMENT



Two full layers of reinforcing are offered for lower power machines, and light to medium applications where speed of cut is the primary selection criterion.



Three full layers of reinforcing are recommended for high speed, high horsepower machines where the application is heavy-duty, and durability is the primary selection criterion.

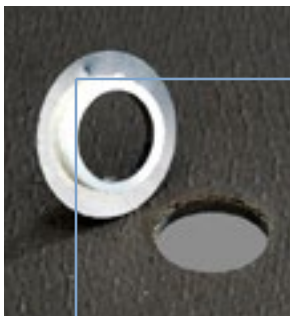

Universal Arbor

Two Blade Sizes in One

Our Norton patent-pending 1"/20mm knock-out arbor fits all gas and electric high speed saws. A 20mm bushing is pre-mounted into the 1" molded arbor hole. The wheel, with the 20mm bushing, can be mounted directly on any 20mm arbor high speed saw. With the bushing removed, exposing the 1" arbor hole, the wheel can be mounted on any 1" arbor high speed saw. Combining this arbor, with heavy-duty triple reinforcing results in a higher performing, extra strong, longer lasting cutting wheel. Once the 20mm bushing is removed, it cannot be replaced.



CROSS REFERENCE GUIDE

SPECIALTY

NORTON

	GOOD Gemini Metal	Gemini Metal Decking	Rail Steel	Gemini Ductile	Gemini Concrete	Gemini Asphalt
Abmast	A 24 R, Kompetitor Metal	A 24 T	Rail-Kut A 24 Z	AC 24 R, Kompetitor Ductile Iron	C 24 R, Kompetitor Concrete	C 16 T, Kompetitor Asphalt
Brilliant	Metal/Stainless	—	A24PB	—	Concrete/Masonry	—
Bullard Blaze & Road Warrior	A24R, ZA24Q, The Competitor	TA24R	A30R	AC24R	C24R, The Competitor	CC20R
Camel	A24-R	A24-T	—	AC24-R	C24-R	C16-U
Flexovit	A24/30SB	A24TB	A30PB	AC24SB	C30UB	C16UB
Husqvarna	Blue XHS, Blue QMS-CM, Blue EHS	Grey QMS-CM	Yellow QMS-CM	Green QMS-CM, Green EHS	Red XHS, Red QHS-CM, Red EHS	Black QMS-AS
Pearl	SRT, Premium A36S, Silver Line A30R	—	—	AC30S	Premium C36S, Silver Line C24R	—
Pferd	A 24 R SG	A 24 Q SG-RAIL	A 24 Q SG-RAIL	AC 24 Q SG	C 24 R SG	—
Sait	A24R, A30S, XFC	Brute	Hobo	Ductile	C24R	Big M.A.C, XFC
Tyrolit	A30P, A30BF	—	—	AC24, AC30BF	1C24, C30BF	—
Virginia Abrasives	Metal	—	—	Ductile	Concrete	Asphalt
Walter	A-24	—	—	—	—	—

AVAILABILITY

TIER:	GOOD	GOOD	GOOD	GOOD	GOOD
BRAND:	Norton	Norton	Norton	Norton	Norton
TRADENAME:	GEMINI METAL HD	GEMINI METAL	GEMINI METAL DECKING	RAIL STEEL	GEMINI RESCUE
SHAPE:	Type 01	Type 01	Type 01	Type 01	Type 01
ABRASIVE:	Aluminum Oxide	Aluminum Oxide	Aluminum Oxide	Aluminum Oxide	Aluminum Oxide
REINFORCING:	3 Layers	2 Layers	2 Layers	2 Layers	2 Layers
MATERIAL:					

SIZE (D x T x H)	MAX. RPM	STD. PKG.	PART NO.	PART NO.	PART NO.	PART NO.	PART NO.
Type 01 Cut-off – for Gas & Electric-Powered Saws							
12 x 1/8 x 1" / 20mm	6,360	10	66252836708	66252837838			
14 x 1/8 x 1" / 20mm	5,400	10	66252835386	66252837841	66252832521		66243578262
14 x 1/8 x 1"	5,400	10				66253260462	
16 x 1/8 x 1" / 20mm	4,800	10		66252830886			
16 x 1/8 x 1"	4,800	10				66253259935	

AVAILABILITY

TIER:	GOOD	GOOD	GOOD	GOOD	GOOD
BRAND:	Norton	Norton	Norton	Norton	Norton
TRADENAME:	GEMINI DUCTILE HD	GEMINI DUCTILE	GEMINI CONCRETE HD	GEMINI CONCRETE	GEMINI ASPHALT
SHAPE:	Type 01	Type 01	Type 01	Type 01	Type 01
ABRASIVE:	Silicon Carbide	Silicon Carbide	Silicon Carbide	Silicon Carbide	Silicon Carbide
REINFORCING:	3 Layers	2 Layers	2 Layers	2 Layers	2 Layers
MATERIAL:					

SIZE (D x T x H)	MAX. RPM	STD. PKG.	PART NO.	PART NO.	PART NO.	PART NO.	PART NO.
Type 01 Cut-off – for Gas & Electric-Powered Saws							
12 x 1/8 x 1" / 20mm	6,360	10		66252837840	66252836709	66252837839	70184670243
14 x 1/8 x 1" / 20mm	5,400	10	66252835388	66252837843	66252835387	66252837842	70184672877
16 x 1/8 x 1" / 20mm	4,800	10				70184623029	



CATEGORY DEFINITION

These powerful, self-propelled machines are designed to cut concrete slabs and asphalt and are normally fitted with diamond blades. For inexperienced operators or small jobs, the machines can accommodate low initial cost, conventional abrasives wheels.

APPLICATIONS:	Cutting straight sections of concrete surfaces
SIZE RANGE:	14" and 18" diameter
THICKNESS RANGE:	3/16" – 3/8"
ABRASIVE GRAIN:	Silicon Carbide
SHAPE:	Type 01 Straight
BOND:	Hot Pressed (HP) – for higher horsepower machine applications where additional durability is needed, may be used wet or dry Cold Pressed (CP) – for lower horsepower machines, which need a free-cutting wheel
ARBOR:	All are 1" with a drive pin

CROSS REFERENCE GUIDE

SPECIALTY

NORTON

Abmast

Bullard Blaze & Road Warrior

Camel

Flexovit

Husqvarna

Pearl

Pferd

Sait

Tyrolit

Virginia Abrasives

Walter

BETTER	GOOD	GOOD
Gemini Asphalt / Green Concrete – HP	Gemini Asphalt	Gemini Concrete
—	C 16 T, Kompetitor Asphalt/Concrete	C 24 R
—	C16R & T, C16R3	—
—	C16-U	C24-R
—	C16 G.P. C16UB	C20SB/C16TB
HPC16AG	Black EWC	Gold RTC, Blue RTC, Blue EWC
Red GC-7A	—	Premium C36S, Silver Line C24R
—	C 24 R SG ASP	C 24 R SG GP
—	C16	C24R, Street Walker
Street Runner	Asphalt CP	Concrete CP
Concrete/Asphalt CHP	GC/Asphalt	Concrete
—	—	C-24

AVAILABILITY

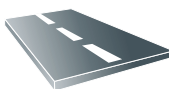
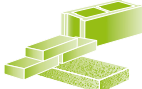
	BETTER	GOOD	GOOD		
TIER:	BETTER	GOOD	GOOD		
BRAND:	Norton	Norton	Norton		
TRADENAME:	GEMINI ASPHALT - HP	GEMINI ASPHALT - CP	GEMINI CONCRETE		
SHAPE:	Type 01	Type 01	Type 01		
ABRASIVE:	Silicon Carbide	Silicon Carbide	Silicon Carbide		
BOND:	Hot Pressed	Cold Pressed	Cold Pressed		
MATERIAL:					
SIZE (D x T x H)	MAX. RPM	STD. PKG.	PART NO.	PART NO.	PART NO.
Type 01 Cut-off – For Walk-Behind Saws					
14 x 3/16 x 1 Pin Hole	4,365	10	70184670100	70184680324	70184680323
14 x 1/4 x 1 Pin Hole	4,365	5	70184670099	70184670535	70184670533
18 x 1/4 x 1 Pin Hole	4,250	5	70184670103	70184670098	
18 x 3/8 x 1 Pin Hole	4,250	5	70184648998		



For higher-production applications, optimum speed of cut and product life, please see our complete selection of walk-behind diamond blades in our Diamond, Abrasives and Equipment for the Construction Market Catalog #7719 found on www.nortonconstructionproducts.com.

**CHOP SAW
REINFORCED CUT-OFF**



NORTON
SAINT-GOBAIN
NORZON
PLUS

NORTON
SAINT-GOBAIN
BLUEfire™

NORTON
SAINT-GOBAIN
GEMINI®



CATEGORY DEFINITION

A chop saw is a light, low horsepower portable machine. Although very similar to a compound miter saw, it is designed for cutting denser materials, like metal bar, tubing or pipe. Chop saw cut-off wheels are designed specifically for this machine with finer grit, softer grades, and reinforcement layers that match the application.

APPLICATIONS:	Cutting small diameter metal pieces, bar stock, metal pipe, tubing, decking, cable, drywall studs, and metal plate dimensioning
SIZE RANGE:	10" - 16" diameter
THICKNESS RANGE:	7/64"
ABRASIVE GRAIN:	Zirconia Alumina/Aluminum Oxide Blend, Aluminum Oxide, Silicon Carbide
SHAPE:	Type 01 Straight
REINFORCEMENT TYPE:	Side reinforced, centrally reinforced

CROSS REFERENCE GUIDE



	BETTER			GOOD			GOOD		
	BlueFire Fast Cut	BlueFire Rapid Cut	BlueFire Long Life	Gemini Fast Cut	Gemini Rapid Cut	Gemini Long Life	Stud Cutter	Gemini Aluminum	Masonry
Brilliant	—	—	—	Super-G	Tube/Pipe	—	Drywall Stud	Aluminum	—
Bullard	ZA36T	—	—	TA36T A46T The Competitor	A36R The Competitor	A36R Ironmaster	A46T Studmaster	AL36R	—
Camel	—	—	ZA24-S	A36-P, WA36-P	—	A36-S	A30-R Mr. Stud	A30-N	—
Dewalt	—	—	XP	GP, Stainless Fabrication	—	—	Stud Cutting	—	—
Flexovit	—	—	—	A30R Fast Cut A30-Q Free Cut	—	A30S Long Life	A30T Drywall Stud	—	—
Makita	—	—	—	—	General Purpose	—	—	—	—
Pearl	SRT36	—	—	A36P Premium	A30P Silver Line	—	A46S Stud Cutting	—	—
Pferd	—	—	—	A 36 K SG CHOP	PSF CHOP	—	A 36 K SG-STUD	—	C 36 K SG-CHOP
Sait	Saitech Steel Worker	Z-tech	—	EZ-Chop	EZ-Chop Attacker	Iron Worker	Stud King	Aluminum	—
Walter	—	—	—	—	A-30	A-30-HC+	—	A30-ALU	—

APPLICATION-TO-PRODUCT RECOMMENDATION GUIDE

WHEEL TYPE/REINFORCEMENT

TYPE 01 STRAIGHT SIDE REINFORCED CUT-OFF WHEEL



Side reinforced wheels have two full layers of reinforcing and are designed for a fast cut and the most aggressive applications. All Purpose, Fast Cut, and Long Life are side reinforced.

TYPE 01 STRAIGHT CENTRALLY REINFORCED CUT-OFF WHEEL

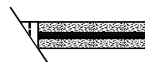

Centrally reinforced wheels have a single layer of reinforcing with exposed rough sides for free-cutting, non-binding applications where minimal burr and burn are the key requirements. Rapid Cut wheels are centrally reinforced.

HOW TO PICK THE RIGHT BOND TYPE

All Purpose	Unmarked	Where an excellent blend of cut rate and life is needed
Fast Cut	FC	Used when fast cutting is desired or when cutting pieces with larger cross sections
Long Life	LL	Where durability is needed due to severe application, and when cutting parts with small cross sections
Rapid Cut	RC	Where a free cutting, non-binding wheel is needed for burn-free and burr-free cuts
High-Performance	STUD	High-performance aluminum oxide/resin bond combination designed for cleaner cuts and longer life when cutting steel studs
Aluminum	ALU	Specially formulated bond for reduced loading/surface contamination when cutting aluminum/soft materials



FEATURED PRODUCTS



NORTON BLUEFIRE CHOP SAW REINFORCED CUT-OFF WHEELS

BETTER CHOICE FOR STEEL, STAINLESS STEEL AND ALL OTHER FERROUS METALS

FEATURES

- Upgraded zirconia alumina / premium aluminum oxide abrasive blend
- Fast Cut: side reinforced
- Long Life: side reinforced
- Rapid Cut: centrally reinforced, rough sides

BENEFITS

- 2X the life and cut rate of aluminum oxide
- Engineered for larger cross-sections and/or hard-to-cut materials
- Ideal for small cross-section workpieces
- Free cutting, non-binding; burr- and burn-free cuts



NORTON GEMINI CHOP SAW REINFORCED CUT-OFF WHEELS

GOOD CHOICE FOR ALL STEEL AND FERROUS METALS AS WELL AS SPECIALTY APPLICATIONS IN ALUMINUM

FEATURES

- Fast Cut: side reinforced
- Long Life: side reinforced
- Rapid Cut: centrally reinforced, rough sides
- Aluminum: specially formulated bond for aluminum and other soft, nonferrous metals; no wax or rubber fillers

BENEFITS

- Engineered for larger cross-sections and/or hard-to-cut materials
- Ideal for small cross-section workpieces
- Free cutting, non-binding; burr- and burn-free cuts
- Free cutting; resist loading
- No surface contamination



NORTON METAL STUD CUTTER CHOP SAW REINFORCED CUT-OFF WHEELS

GOOD CHOICE FOR DRYWALL STUDS

FEATURES

- Stud Cutter: thin, side-reinforced; with high-performance aluminum oxide abrasive

BENEFITS

- Designed specifically for cutting steel studs

AVAILABILITY

TIER:	BETTER	BETTER	GOOD	GOOD	GOOD	GOOD
TRADENAME:	NORTON BLUEFIRE	NORTON BLUEFIRE	NORTON GEMINI	NORTON GEMINI	NORTON METAL	NORTON MASONRY
SHAPE:	Type 01	Type 01	Type 01	Type 01	Type 01	Type 01
ABRASIVE:	Zirconia Alumina/ Aluminum Oxide	Zirconia Alumina/ Aluminum Oxide	Aluminum Oxide	Aluminum Oxide	Aluminum Oxide	Silicon Carbide
REINFORCING:	Side	Central	Side	Central	Side	Side
MATERIAL:	STAINLESS STEEL/METAL	STAINLESS STEEL/METAL	STAINLESS STEEL/METAL	STAINLESS STEEL/METAL	STAINLESS STEEL/METAL	MASONRY
SIZE (D x T x H)	MAX. RPM	STD. PKG.	PART NO.	PART NO.	PART NO.	PART NO.

Type 01 Straight Cut-off						
10 x 7/64 x 1	6,110	10			66253106109 LL	
12 x 7/64 x 1	5,095	10	66252843250		66253207554 LL	66253214561 RC
		5				07660789400
14 x 7/64 x 1	4,365	10	66252843252 FC	66252843254 RC	66252835554	66253313588 RC
		10	66252843253 LL		66253306627 FC	07660789405 STUD
		10			66253306626 LL	
		10			66253314816 ALU	
		25				07660703970 5 Pk
		5				07660789399
16 x 7/64 x 1	3,820	10	66252843256 FC		66253410198 LL	07660789402
		10	66252843257 LL			

CUT-OFF WHEEL DESCRIPTION CODES				
ALU = ALUMINUM	FC = FREE CUT	LL = LONG LIFE	RC = RAPID CUT	STUD = STUD CUTTER
M = MASONRY	S = STAINLESS	ST = STEEL / METAL		



CATEGORY DEFINITION

The Norton stationary saw reinforced cut-off wheel line consists of Type 01 straight 10" - 24" wheels, designed to fit on fixed-base stationary saws that are free-standing or mounted on a workbench.

APPLICATIONS:	Primary applications are cutting of all metal parts (flat stock, bars, studs, pipes, tubes, angle iron, cable), wire rope and hydraulic hose used in fabrication, construction and plant maintenance.
SIZE RANGE:	10" – 24" diameter
THICKNESS RANGE:	3/32", 1/8", 5/32", 3/16"
ABRASIVE GRAIN:	Zirconia Alumina/Aluminium Oxide Blend, Aluminum Oxide, Silicon Carbide
SHAPE:	Type 01 Straight

CROSS REFERENCE GUIDE



NORTON	BETTER	GOOD			GOOD	
	BlueFire	Gemini Fast Cut	Gemini Long Life	Gemini Rapid Cut*	Norton Masonry	Foundry Cut**
Abmast	Z 24 R3	A 30 R	—	—	—	AC 24 R3
Brilliant	—	GP Fast Cut	GPX Long Life	XL , XLX	—	—
Bullard	—	A30-R	A30-T	A300	C20R	—
Camel	ZA24-R	A24-R, A46-T	—	—	C24-R	WA24-S
Flexovit	—	A30RB Multi Purpose	A30SB Long Life, A24TB Long Life	—	C24RB	AC24PB Heavy Duty
Metabo	—	A30N, A30R	A30S, A30V	—	C30S	—
Pearl	SRT36	A30P Premium, A30Q Silver Line	A30S Premium, A36R Premium	—	C24 Silver Line	—
Pferd	ZA 24 Q/R SG-HD	A 24 N/P SG-HD	A 24 Q/S SG-HD	—	C 24 0 SG	—
Sait	—	A24N, A36R	A24R	—	C24R	—
Tyrolit	—	A30BF	—	—	C30BF	—
Walter	—	A-24-FC	A-24-RIP	—	—	—

* FOR BURR-FREE APPLICATIONS, PLEASE REFER TO GEMINI RAPID CUT WHEELS IN CHOP SAW CUT-OFF WHEEL SECTION OR AT WWW.NORTONABRASIVES.COM

** FOR FOUNDRY AND OTHER PRODUCTION CUT-OFF WHEELS, PLEASE REFER TO THAT SECTION OF THE NORTON FULL LINE CATALOG #7362 OR AT WWW.NORTONABRASIVES.COM

AVAILABILITY

TIER:	NEW					
	BETTER	GOOD	GOOD	GOOD		
TRADENAME:	NORTON BLUEFIRE	NORTON GEMINI FREE CUT	NORTON GEMINI LONG LIFE	NORTON MASONRY		
SHAPE:	Type 01	Type 01	Type 01	Type 01		
ABRASIVE:	Zirconia Alumina/ Aluminum Oxide	Aluminum Oxide	Aluminum Oxide	Silicon Carbide		
MATERIAL:	STAINLESS	STAINLESS	STAINLESS	MASONRY		
	STEEL/METAL	STEEL/METAL	STEEL/METAL	MASONRY		
SIZE (D x T x H)	MAX. RPM	STD. PKG.	PART NO.	PART NO.	PART NO.	PART NO.
Type 01 Straight Cut-off						
10 x 3/32 x 5/8	6,110	10 5	66252843248	66253106101 FC	66253106102 LL	07660789391
12 x 1/8 x 1	5,095	10 5	66252843249	66253207547 FC	66253207548 LL	07660789350
14 x 1/8 x 1	4,365	10 5	66252843251	66253306609 FC	66253306611 LL	07660789353 70184623029
16 x 1/8 x 1	3,820	10		66253422942		
16 x 5/32 x 1	3,820	10	66252843255	66253410183 FC	66253410184 LL	
18 x 5/32 x 1	3,015	10		66253410185 FC		
20 x 5/32 x 1	2,710	5 5	66252843258 FC 66252843259 LL	69078609031 FC	69078609032 LL	
20 x 3/16 x 1	2,710	5		69078609033 FC	69078609034 LL	
24 x 3/16 x 1-3/4	2,260	5		61463650196 FC		

CUT-OFF WHEEL DESCRIPTION CODES

FC = FREE CUT **LL** = LONG LIFE **BLANK** = ALL PURPOSE ■ = STAINLESS ■ = STEEL / METAL ■ = MASONRY

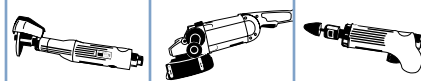

CATEGORY DEFINITION

For consistent, quality performance in foundries, welding shops, fabrication facilities, steel mills and shipyards, Norton snagging wheels maximize your productivity. Used on horizontal/straight shaft grinders or right angle cup portable grinders.

- APPLICATIONS:** Removing flaws, cracks, gates, risers and parting lines, smoothing weld seams, cleaning castings, and rough beveling
- SIZE RANGE:** Type 01 Straight Wheels: 2-1/2" – 8" diameter
Type 06 and 11 Cup Wheels: 4" – 6" diameter
Cones and Plugs: Type 16, 17, 17R, 18 and 18R
- GRIT RANGE:** 14 – 24
- ABRASIVE TYPES:** Zirconia Alumina NZ, 4NZ, Zirconia Alumina/Aluminum Oxide Blend AZ, Zirconia Alumina/Silicon Carbide Blend NZC, AZC, Aluminum Oxide 57A, Aluminum Oxide/Silicon Carbide Blend 57AC, Silicon Carbide 37C



MATERIAL-TO-PRODUCT RECOMMENDATION GUIDE

		BEST HIGHEST PRODUCTIVITY LOWEST TOTAL COST	BETTER EXCELLENT BLEND OF PERFORMANCE & PRICE	GOOD CONSISTENT PERFORMANCE LOW INITIAL PRICE
Iron	Gray	NorZon Plus NZ14-R	BlueFire 4NZ16-QBX406	Gemini 57A16-Q
	Ductile/Malleable	NorZon Plus NZ14-R	BlueFire 4NZ16-QBX406	Gemini 57A16-Q
	Dirty/Scale-covered		BlueFire NZC16-QBX406	Gemini 57AC16-Q
Steel	Carbon and Low Alloy	NorZon Plus NZ16-Q	BlueFire 4NZ16-QBX406	Gemini 57A16-Q
	Stainless and High Alloy	NorZon Plus NZ16-P	BlueFire 4NZ16-QBX406	Gemini 57A16-Q
Aluminum, Copper, Brass, & Bronze Alloys			BlueFire NZC16-QBX406	Gemini 57AC16-Q

NOTE: GRADE, GRIT AND ABRASIVE TUNING MAY BE NECESSARY TO OBTAIN OPTIMUM PERFORMANCE

CROSS REFERENCE GUIDE FOR TYPE 01, 06 AND 11

TOTAL PERFORMANCE ←

INITIAL PRICE →

NORTON	BEST	BETTER		GOOD		
	NorZon Plus NZ	BlueFire 4NZ	BlueFire NZC	Gemini 57A	Gemini 57AC	Gemini 37C
Brilliant	—	ZA16QB	—	A16QB	—	C16QB
Bullard	—	ZA16PB	—	A16R	AC16	C16P
Camel	—	—	—	A	CA	C
Flexovit	ZA16PB	—	—	A16QB	AC16QB	C16PB
Gulf States	Zirconium	—	—	A16	—	C16
Pacific	Z, Z-GPC	—	—	A	CA	—
Pearl	—	—	—	A16Q	—	C16-Q
Pferd	ZA 16 Q SG	—	—	A 16 Q SG	—	C 16 Q SG
Sait	—	Z16	—	A16, 20	CA16	C16
Tyrolit	—	—	—	A16PB	—	C16PB
Walter	—	—	—	A	—	C

FEATURED PRODUCTS



NORTON NORZON PLUS WHEELS, CONES AND PLUGS

BEST CHOICE FOR HEAVY-DUTY STOCK REMOVAL ON HIGH HORSEPOWER GRINDERS

FEATURES

- NZ Plus (NorZon) – premium zirconia alumina grain

BENEFITS

- Engineered for high-powered machines 10X life, 50% faster grinding versus aluminum oxide



NEW

NORTON BLUEFIRE SNAGGING WHEELS, CONES AND PLUGS

BETTER CHOICE FOR STOCK REMOVAL ON HIGH AND MEDIUM HORSEPOWER GRINDERS

FEATURES

- More friable zirconia alumina grain and durable resin bond technologies
- NZC – zirconia alumina/silicon carbide blend

BENEFITS

- Higher metal removal rates, faster, freer-cutting than standard zirconia alumina blends
- Up to 5X the life of aluminum oxide with better grinding action
- Highly effective on dirty, scale-covered castings

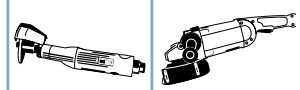

AVAILABILITY

TIER:	BEST	BETTER	BETTER	GOOD
TRADENAME:	NORTON NORZON PLUS	NORTON BLUEFIRE	NORTON CHARGER	NORTON GEMINI
SHAPE:	Type 01	Type 01	Type 01	Type 01
ABRASIVE:	Zirconia Alumina	Zirconia Alumina 4NZ Zirconia Alumina/ Silicon Carbide NZC	Zirconia Alumina/ Aluminum Oxide AZ, Zirconia Alumina/ Silicon Carbide AZC	Aluminum Oxide 57A, Silicon Carbide 37C, Aluminum Oxide/ Silicon Carbide 57AC

SIZE (D x T x H)	MAX. RPM	STD. PKG.	SPEC	PART NO.	SPEC	PART NO.	SPEC	PART NO.	SPEC	PART NO.
Type 01 Straight										
2-1/2 x 1/2 x 3/8	21,700	10							57A24-R	66243522381
3 x 1/4 x 3/8	20,370	10					AZ20-T	66243509999**	57A24-T	66243528831
3 x 3/8 x 3/8	18,080	10							57A24-R	66243522415
3 x 1/2 x 3/8	18,080	10							57A24-P	66243522417
4 x 1/4 x 3/8	15,280	10					AZ20-T	66243510000	57A24-R	66243522221
6 x 1 x 5/8	8,000	5	NZ14-Q	66252838075			AZC16-Q	66252837965		
S Webs		10	NZ14-R	66252837961	4NZ14-RBSX406	66253198589			57A16-QS	66252809563
8 x 3/4 x 5/8	6,000	10					AZ14-R	66253006674		
S Webs										
8 x 1 x 5/8	6,000	5	NZ16-O	66253030778			AZC14-Q	66253030782		
S Webs		10	NZ16-Q	66253044532	4NZ16-QBSX406	66253198590	AZ14-R	66253006672		
					NZC16-QBSX406	66253198592	AZ14-T	66253006673		
Type 06 Straight Cup										
6 x 2 x 5/8-11	6,000	5	NZ16-R	66252838577						
Rim 2" Back 3/4"										
Type 11 Flaring Cup										
4/3 x 2 x 5/8-11	9,070	10	NZ16-Q	66243530761	4NZ16-QBX406	66253198583			57A16-Q	66243510512
Rim 3/4" Back 3/4"										
5/3-3/4 x 2 x 5/8-11	7,260	10			4NZ16-QBX406	66253146918			57A16-Q	66252809598
Rim 1" Back 3/4"										
6/4-3/4 x 2 x 5/8-11	6,000	5	NZ16-Q	66252838568	4NZ16-QBX406	66253146925	AZ16-P	66252825197	57A16-Q	66252825201
Rim 1" Back 3/4"			NZ16-R	66252838566						
6/4-3/4 x 2 x 5/8-11	6,000	5	NZ16-P	66252830765	4NZ16-QBX406	66253198584	AZ14-R	66252809211	37C16-P	66252809609
Rim 1-1/2" Back 3/4"					NZC16-QBX406	66253146922			57A16-Q	66252809618
									57AC16-Q	66252809608
Type 11 Flaring Cup with Steel Back										
4/3 x 2 x 5/8-11	9,070	10			4NZ16-QBX406	66253146917				
Rim 3/4" Back 3/4"										
5/3-13/16 x 2 x 5/8-11	7,260	10			4NZ16-QBX406	66253146920				
Rim 1" Back 3/4"										
6/4-13/16 x 2 x 5/8-11	6,000	5			4NZ16-QBX406	66253198586	AZ14-R	66252809213	57A16-Q	66252809599
Rim 1-1/2" Back 3/4"					NZC16-QBX406	66253146929	AZ16-Q	66252809212	57AC16-Q	66252809600





** STD.PKG. = 50



AVAILABILITY



TIER:	BEST	BETTER	GOOD
TRADENAME:	NORTON NORZON PLUS	NORTON CHARGER	NORTON GEMINI
ABRASIVE:	Zirconia Alumina	Zirconia Alumina/Aluminum Oxide	Aluminum Oxide

SIZE (D x T x H)	MAX. RPM	STD. PKG	SPEC	PART NO.	SPEC	PART NO.	SPEC	PART NO.
Type 16 Cones 								
1 x 3 x 3/8-24 (ME 107019)	36,290	10					57A24-R	61463622342
1-1/2 x 2-1/2 x 3/8-24 (ME 44436)	24,190	10					57A24-R	61463622349
1-1/2 x 3 x 3/8-24 (ME 139029)	24,190	10			AZ24-R	61463614587		
1-1/2 x 3 x 5/8-11 (ME 70535)	24,190	10	NZ20-R	61463644231	AZ20-R	61463614588	57A24-R	61463622190
1-3/4 x 3 x 3/8-24 (ME49226)	20,735	10					57A24-R	61463614503
1-3/4 x 3 x 5/8-11 (ME 33432)	20,740	10					57A24-R	61463622195
2 x 3 x 5/8-11 (ME 28229)	18,145	10	NZ20-R	61463644232	AZ20-R	61463614604	57A24-R	61463622218
2-3/4 x 3-1/2 x 5/8-11 (ME 18265)	13,195	10			AZ16-R	61463614599	57A24-R	61463622387
Type 17 Cones, Square Tip 								
1-1/2 / 1/2 x 3 x 3/8-24	24,190	10					57A24-R	61463622194
2 / 1/2 x 3 x 5/8-11	18,145	10					57A24-R	61463615722
Type 17R Cones, Round Tip 								
2 / 3/4 x 3 x 5/8-11 (ME 151373)	18,145	10			AZ20-R	61463615866		
Type 18 Plugs, Square Tip 								
1-1/2 x 2-1/2 x 3/8-24	24,190	10					57A24-R	61463622217
1-1/2 x 2-1/2 x 5/8-11	24,190	10	NZ20-R	61463644224	AZ20-R	61463644256	57A24-R	61463622351
1-1/2 x 3 x 5/8-11	24,190	10			AZ20-R	61463644257	57A24-R	61463622191
2 x 3 x 5/8-11	18,145	10	NZ20-R	61463644234	AZ20-R	61463614601	57A24-R	61463622219
					AZ24-R	61463614595		
2 x 4 x 5/8-11	18,145	10					57A24-R	61463622366
Type 18R Plugs, Round Tip 								
1-1/2 x 3 x 3/8-24	24,190	10					57A24-R	61463622192
2 x 3 x 5/8-11	18,145	10			AZ20-R	61463644259	57A24-R	61463622220

AVAILABILITY



TIER:	GOOD
BRAND:	NORTON
ABRASIVE:	Silicon Carbide

SIZE (T x W x L)	STD. PKG.	SPEC.	PART NO.
Stock Resinoid Core Files – Silicon Carbide			
1/2 x 1 x 10	5	37C24-SB	61463610314



CATEGORY DEFINITION

The Norton bench and pedestal wheel line consists of all wheel diameters and arbor sizes, abrasive types and grit sizes. Our offering answers all metal removal, deburring, shaping and sharpening needs: white aluminum oxide for high speed tool steels, gray aluminum oxide for carbon steel, and silicon carbide for non-ferrous metals and carbide tooling.

- APPLICATIONS:** Offhand deburring and sharpening of parts and tools
- SIZE RANGE:** 5" – 12"
- GRIT RANGE:** 24 – 150
- ABRASIVE TYPES:** Aluminum Oxide (Alundum), Silicon Carbide (Crystolon)
- BUSHINGS:** Telescopic arbor bushings to fit all popular grinders are packaged with the wheel

APPLICATION/GRIT RECOMMENDATION GUIDE

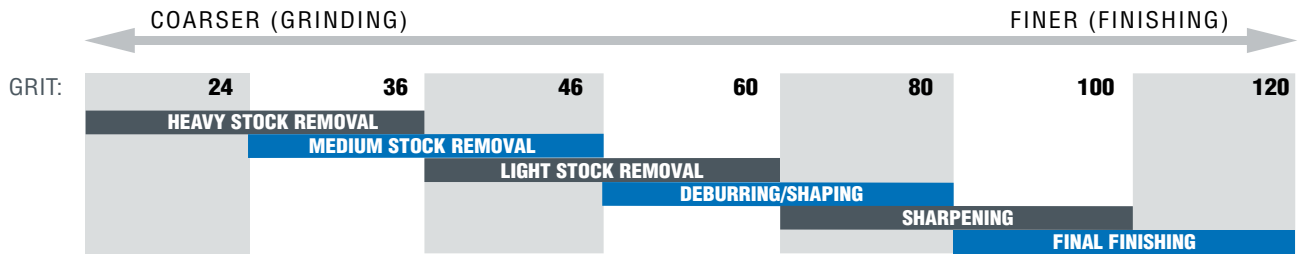

FEATURED PRODUCTS



PREMIUM WHITE ALUMINUM OXIDE

BETTER CHOICE FOR LIGHT METAL REMOVAL AND SHARPENING OF HIGH-SPEED TOOL STEELS (55 RC AND HIGHER)

FEATURES

- White aluminum oxide in a premium vitrified bond

BENEFITS

- Maximum cut rate and cool grinding action on hardened or high-speed tool steels



NORTON GEMINI ALUMINUM OXIDE

GOOD CHOICE FOR ALL GENERAL-PURPOSE BENCH AND PEDESTAL APPLICATIONS

FEATURES

- Quality, gray aluminum oxide

BENEFITS

- Economical prices; ideal for small job shops and numerous general-purpose applications

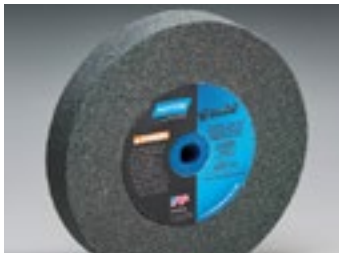

NORTON GEMINI SILICON CARBIDE

GOOD CHOICE FOR ALL GENERAL-PURPOSE BENCH AND PEDESTAL APPLICATIONS ON NONFERROUS MATERIALS AND CARBIDE TOOLING

FEATURES

- Sharp, green silicon carbide

BENEFITS

- Economical prices; ideal for small job shops and numerous general-purpose applications



AVAILABILITY



BETTER



GOOD



GOOD

TIER:

BRAND:

TRADENAME:

ABRASIVE:

Norton

Norton

Norton

PREMIUM ALUNDUM

GEMINI ALUNDUM

GEMINI CRYSTOLON

White Aluminum Oxide

Gray Aluminum Oxide

Green Silicon Carbide

SIZE (D x T x H)	MAX. RPM	MIN./STD. PKG.	SPEC	PART NO.	SPEC	PART NO.	SPEC	PART NO.
5 x 1/2 x 1	4,965	1/5			Medium 60/80 Fine 100/120	07660788202 07660788201		
5 x 3/4 x 1	4,965	1/5			Coarse 36/46 Medium 60/80 Fine 100/120	07660788215 07660788210 07660788205		
5 x 1 x 1	4,965	1/5			Coarse 36/36 Medium 60/80	07660788230 07660788225		
6 x 1/2 x 1	4,140	1/5			Coarse 36/46 Medium 60/80 Fine 100/120	66252836132 66252836131 66252836133	Medium 60 Fine 80 Extra Fine 120	66252836571 66252836572 66252836573
6 x 3/4 x 1	4,140	1/5	Medium 60 Fine 100 Very Fine 150	07660788246 07660788247 07660788248	Coarse 36/46 Medium 60/80 Fine 100/120	07660788245 07660788240 07660788235	Medium 60 Fine 80 Extra Fine 120	66252837190 66252837191 66252837192
6 x 1 x 1	4,140	1/5	Medium 60 Fine 100 Very Fine 150	07660788261 07660788262 07660788263	Coarse 36/46 Medium 60/80 Fine 100/120	07660788260 07660788255 07660788250	Medium 60 Fine 80 Extra Fine 120	66252837187 66252837193 66252837194
7 x 1 x 1	3,600	1/5			Coarse 36/46 Medium 60/80 Fine 100/120	07660788275 07660788270 07660788265	Medium 60 Fine 80 Extra Fine 120	66252942300 66252942301 66252942302
8 x 3/4 x 1	3,600	1/5			Coarse 36/46 Medium 60/80 Fine 100/120	07660788278 07660788277 66253042317		
8 x 1 x 1	3,600	1/5	Medium 60 Fine 100 Very Fine 150	07660788281 07660788282 07660788283	Very Coarse 24 Coarse 36/46 Medium 60/80 Fine 100/120	66253044454 07660788286 07660788285 07660788280	Medium 60 Fine 80 Extra Fine 120	66253044087 66253044534 66253044535
10 x 1 x 1-1/4	2,485	1/2			Very Coarse 24 Coarse 36/46 Medium 60/80 Fine 100/120	66253160788 07660788295 07660788290 66253160350	Medium 60 Fine 80	66253144536 66253160366
10 x 1-1/4 x 1-1/4	2,485	1/2			Coarse 36/46 Medium 60/80	66253161250 66253161251		
10 x 1-1/2 x 1-1/4	2,485	1/2			Coarse 36/46 Medium 60/80	66253161393 66253161395		
12 x 1-1/2 x 1-1/2	2,070	1/2			Coarse 36/46 Medium 60/80	66253263052 66253263053		
12 x 2 x 1-1/4	2,070	1/2					Medium 60 Fine 80	66253263359 66253263360
12 x 2 x 1-1/2	2,070	1/2			Very Coarse 24 Coarse 36/46 Medium 60/80	66253263054 66253263055 66253263056		

Bench and Pedestal Wheel Arbor Bushings

WHEEL DIAMETER	WHEEL CENTER HOLE	1/2"	5/8"	3/4"	7/8"	1"	1-1/4"
5", 6", 7"	1"	•	•	•	•		
8"	1"		•	•	•		
10"	1-1/4"			•	•	•	
12" x 2"	1-1/4"					•	
12"	1-1/2"					•	•

THESE SIZE BUSHINGS SHIPPED FREE OF CHARGE WITH YOUR WHEEL ORDER.

TECHtip

- Unsecured machines can move, causing grinding breakage and injury. Fixed-based bench and pedestal grinders **MUST** be secured.
- Do not grind wood, plastic or any other non-metallic material on a bench or pedestal grinder.
- All bench and pedestal wheels must be dressed to prevent loading. Loading can cause excessive heat, damage to the workpiece, and wheel breakage. Dressing exposes new cutting edges and provides chip clearance.
- Recommended Starting Dressing Stick:
1 x 1 x 6 37C24-SVK Part No. 61463610462.



It is the user's responsibility to refer to and comply with ANSI B7.1



CATEGORY DEFINITION

Resin bond, vitrified bond, center lap, and cotton fiber mounted points are available in a wide range of shapes.

- INDUSTRIES:**
- Aerospace
 - Tool and Die
 - Construction
 - Metal Fabrication
 - Automotive
 - Cutlery
 - Mold Shops
 - Stainless Steel Equipment
 - Foundries

ABRASIVE GRAIN: Ceramic Alumina, Zirconia Alumina, Aluminum Oxide, Silicon Carbide

SHAPE AVAILABILITY: A, B, and W

MEASUREMENT GUIDE

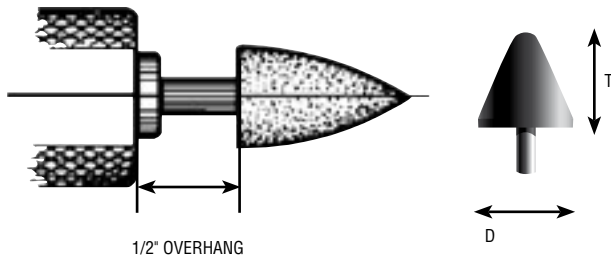

DESCRIPTION OF OVERHANG

Overhang is the distance between the grinder chuck and the abrasive on the spindle. The larger the overhang, the lower the maximum safe operating speed.

SIZE

Measured by diameter (D) x thickness (T)

FEATURED PRODUCTS



CENTER LAP MOUNTED POINTS

FOR EXCELL-O CENTER LAP AND SIMILAR MACHINES

FEATURES

- Specially formulated wheel treatment (#5 wood resin)
- Larger diameter spindle
- Precise dimensional tolerances

BENEFITS

- Adds lubricity to the wheel, minimizing risk of metallurgical damage
- Minimum deflection, rigid support
- Ensure accurate location of part centers

AVAILABILITY

TIER:	BETTER
BRAND:	Norton
TRADENAME:	CENTER LAP
ABRASIVE:	Aluminum Oxide

SHAPE	SIZE (D x T)	SPINDLE DIA. †	MAX. RPM*	MIN./STD. PKG.	SPEC	PART NO.
Center Lap Mounted Points						
-	1/2 x 2**	1/2	65,000	5/25	A80-VVM	61463621421
-	1 x 2**	1/2	15,900	5/25	A80-VVM	61463622926

** POINTED 60°
 † SPINDLE LENGTH IS 1-1/4"
 * MAXIMUM OPERATING SPEED BASED ON 1/2" OVERHANG

TECHtip

Dress the center lap mounted points frequently to ensure accurate and smooth center holes.



It is the user's responsibility to refer to and comply with ANSI B7.1



COTTON FIBER MOUNTED POINTS
GOOD FOR BLENDING AND POLISHING

FEATURES

- 80 grit
- 120 grit

BENEFITS

- For most materials
- For polishing and stainless steel applications

AVAILABILITY

TIER:	GOOD
BRAND:	Norton
TRADENAME:	COTTON FIBER
ABRASIVE:	Aluminum Oxide

SHAPE	SIZE (D x T)	SPINDLE DIA. †	MAX. RPM*	MIN./STD. PKG.	SPEC	PART NO.
Cotton Fiber Mounted Points						
A11	7/8 x 2	1/4	19,860	25/25	A80-HBF3	61463622664
B52	3/8 x 3/4	1/8	45,370	25/25	A120-HBF3	61463620242
B121	1/2" Ball	1/8	45,370	25/25	A80-HBF3	61463622657
W163	1/4 x 1/2	1/8	60,000	25/25	A80-HBF3	61463622655
					A120-HBF3	61463622656
W176	3/8 x 1/2	1/8	45,370	25/25	A80-HBF3	61463622654
W185	1/2 x 1/2	1/8	34,500	25/25	A80-HBF3	61463622649
W187	1/2 x 1	1/8	20,620	25/25	A80-HBF3	61463622651
W220	1 x 1	1/4	25,500	25/25	A80-HBF3	61463622646

† SPINDLE LENGTH IS 1-1/2"

* MAXIMUM OPERATING SPEED BASED ON 1/2" OVERHANG

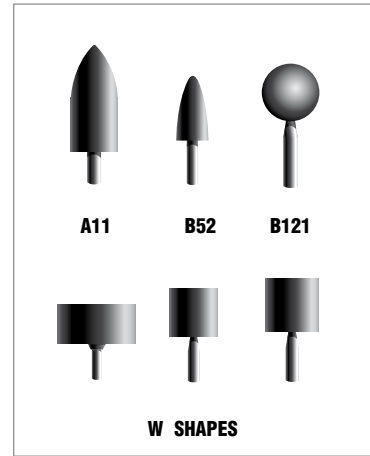

NORTON NORZON – RESIN BOND MOUNTED POINTS
BEST CHOICE FOR FAST STOCK REMOVAL

FEATURES

- NZ (NorZon) zirconia alumina self-sharpening abrasive and durable organic bond

BENEFITS

- 2X faster stock removal than competitive aluminum oxide products
- Last 4X longer



NORTON CHARGER – RESIN BOND MOUNTED POINTS
BETTER CHOICE FOR FAST STOCK REMOVAL AND LONG LIFE

FEATURES

- Zirconia alumina/aluminum oxide abrasive blend
- Specially formulated organic bond

BENEFITS

- 35% faster cut rate than standard aluminum oxide
- An aggressive, free cut
- More parts cleaned in less time to substantially increase productivity
- 2X greater life than ordinary aluminum oxide
- Reduces vibration and wheel chatter

AVAILABILITY

TIER:	BEST	BETTER
BRAND:	Norton	Norton
TRADENAME:	NORZON	CHARGER
ABRASIVE:	Zirconia Alumina	Zirconia Alumina/Aluminum Oxide

SHAPE	SIZE (D x T)	SPINDLE DIA. †	MAX. RPM*	MIN./STD. PKG.	SPEC	PART NO.	SPEC	PART NO.
Resin Bond Mounted Points								
A1	3/4 x 2-1/2	1/4	19,800	5/25	NZ24-UBXR1	61463616457	Charger	61463616458
A3	1 x 2-3/4	1/4	16,100	5/25	NZ24-UBXR1	61463616459	Charger	61463616460
A5	3/4 x 1-1/8	1/4	45,000	5/25			Charger	61463616462
A11	7/8 x 2	1/4	19,860	5/25	NZ24-UBXR1	61463616463	Charger	61463616464
W189	1/2 x 2	1/4	24,000	5/25	NZ24-UBXR1	61463616465	Charger	61463616466
W197	5/8 x 2	1/4	21,000	5/25	NZ24-UBXR1	61463616467		
W207	3/4 x 1-1/2	1/4	24,000	5/25			Charger	61463616470
W208	3/4 x 2	1/4	18,750	5/25	NZ24-UBXR1	61463616471	Charger	61463616472
W220	1 x 1	1/4	25,500	5/25	NZ24-UBXR1	61463617520	Charger	61463617521
W221	1 x 1-1/2	1/4	19,120	5/25	NZ24-UBXR1	61463616473	Charger	61463616474
W222	1 x 2	1/4	15,900	5/25	NZ24-UBXR1	61463616475	Charger	61463616476

† SPINDLE LENGTH IS 1-1/2"

* MAXIMUM OPERATING SPEED BASED ON 1/2" OVERHANG

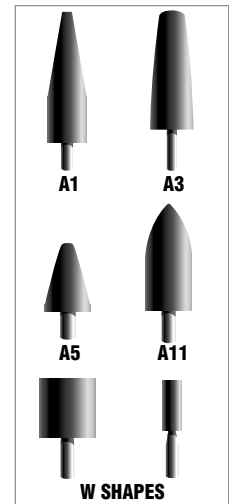



EXPANDED OFFERING

NORTON QUANTUM – VITRIFIED BOND MOUNTED POINTS

BEST CHOICE FOR HIGH VOLUME OPERATIONS

FEATURES

- Unique, engineered ceramic grain shape and chemistry with proven bond technology
- NEW! Oil and Gas 36 grit mounted points

BENEFITS

- Ideal for high-volume foundry operations – grinding Inconel and similar alloy turbine blade components
- Minimal loading and heat build-up
- 33% + longer life versus competitive ceramic products
- 30% + higher metal removal rates
- Versatile, optimized for all low-, medium- and high-force applications
- Exceptional productivity and life
- Specifically engineered to efficiently grind the carbide matrix material of oilfield drill heads



NORTON GEMINI – VITRIFIED BOND MOUNTED POINTS

GOOD VALUE FOR GENERAL PURPOSE, SMALL JOB SHOP APPLICATIONS

FEATURES

- 38A abrasive
- Diverse shapes and sizes

BENEFITS

- Cool cutting, less burn
- Ideal when initial price is the main purchasing consideration

AVAILABILITY

TIER:	BEST	GOOD
BRAND:	Norton	Norton
TRADENAME:	QUANTUM	GEMINI
ABRASIVE:	Ceramic Alumina	38A

SHAPE	SIZE (D x T)	SPINDLE DIA.†	MAX. RPM*	MIN./STD. PKG.	SPEC	PART NO.	SPEC	PART NO.
Vitrified Bond Mounted Points – A Shapes								
A1	3/4 x 2-1/2	1/4	19,800	25/250	Oil & Gas 36	61463686139		
A1	3/4 x 2-1/2	1/4	19,800	5/25	3NQ80	69083149139	38A36-T	61463624374
A1	3/4 x 2-1/2	1/4	19,800	5/25			38A60-P	61463624375
A3	1 x 2-3/4	1/4	16,100	25/250	Oil & Gas 36	61463686138		
A3	1 x 2-3/4	1/4	16,100	5/25			38A36-T	61463624377
A3	1 x 2-3/4	1/4	16,100	5/25			38A60-P	61463624378
A4	1-1/4 x 1-1/4	1/4	30,560	5/25			38A60-P	61463624380
A5	3/4 x 1-1/8	1/4	45,000	5/25			38A36-T	61463624381
A5	3/4 x 1-1/8	1/4	45,000	5/25			38A60-P	61463624382
A11	7/8 x 2	1/4	19,860	5/25	3NQ80	69083149141	38A36-T	61463624384
A11	7/8 x 2	1/4	19,860	5/25			38A60-P	61463624385
A12	11/16 x 1-1/4	1/4	48,000	5/25	3NQ60	61463677679	38A60-P	61463624388
A13	1-1/8 x 1-1/8	1/4	33,950	5/25			38A60-P	61463624389
A14	11/16 x 7/8	1/4	55,560	5/25			38A60-P	61463624390
A15	1/4 x 1-1/16	1/4	72,750	5/25			38A60-P	61463624391
A21	1 x 1	1/4	34,500	5/25	3NQ80	69083149144	38A60-P	61463624392
A23	3/4 x 1	1/4	39,370	5/25	3NQ80	69083149143	38A60-P	61463624394
A24	1/4 x 3/4	1/4	76,500	5/25			38A60-P	61463624395
A25	1" Ball	1/4	35,620	5/25	3NQ80	61463677680	38A60-P	61463624396
A26	5/8" Ball	1/4	61,120	5/25	3NQ80	69083149145	38A60-P	61463624397
A31	1-3/8 x 1	1/4	27,780	5/25			38A60-P	61463624399
A34	1-1/2 x 3/8	1/4	25,470	5/25			38A60-P	61463624402
A36	1-5/8 x 3/8	1/4	23,520	25/250	Oil & Gas 36	66253145562		
A36	1-5/8 x 3/8	1/4	23,520	5/25	3NQ80	69083149146	38A60-P	61463624404
A37	1-1/4 x 1/4	1/4	30,560	5/25			38A60-P	61463624405
A38	1 x 1	1/4	34,500	5/25	3NQ80	61463677682	38A60-P	61463624406
A39	3/4 x 3/4	1/4	47,250	5/25	3NQ80	69083149147	38A60-P	61463624407
A40	3/4" Ball	1/4	47,250	5/25			38A60-P	61463624408

† STANDARD SPINDLE SIZE IS 1/4" X 1-1/2"
* MAXIMUM OPERATING SPEED BASED ON 1/2" OVERHANG





AVAILABILITY

TIER:	BEST	GOOD
BRAND:	Norton	Norton
TRADENAME:	QUANTUM	GEMINI
ABRASIVE:	Ceramic Alumina	38A

SHAPE	SIZE (D x T)	SPINDLE DIA.†	MAX. RPM*	MIN./STD. PKG.	SPEC	PART NO.	SPEC	PART NO.
Vitrified Bond Mounted Points – B Shapes								
B41	5/8 x 5/8	1/8	33,570	5/25			38A60-P	61463624410
B42	1/2 x 3/4	1/8	33,570	5/25	3NQ80	69083149045	38A60-P	61463624412
B43	1/4 x 5/16	1/8	81,370	5/25			38A60-P	61463624413
B44	7/32 x 3/8	1/8	68,400	5/25			38A60-P	61463624414
B45	3/16 x 5/16	1/8	104,250	5/25			38A60-P	61463624415
B46	1/8 x 5/16	1/8	105,000	5/25			38A60-P	61463624416
B51	7/16 x 3/4	1/8	45,370	5/25			38A60-P	61463624418
B52	3/8 x 3/4	1/8	45,370	5/25	3NQ80	69083149046	38A60-P	61463624420
B52	3/8 x 3/4	1/4	81,000	5/25			38A60-P	61463624419
B52	3/8 x 3/4	1/8	45,370	5/25			38A90-Q	61463624422
B53	5/16 x 5/8	1/8	60,000	5/25			38A60-P	61463624423
B54	1/4 x 1/2	1/8	60,000	5/25			38A60-P	61463624424
B55	1/8 x 1/4	1/8	105,000	5/25			38A60-P	61463624425
B81	3/4 x 3/16	1/8	50,930	5/25			38A60-P	61463624437
B91	1/2 x 5/8	1/8	34,500	5/25			38A60-P	61463624443
B96	1/8 x 1/4	1/8	105,000	5/25			38A60-P	61463624448
B96	1/8 x 1/4	1/8	105,000	5/25			38A90-Q	61463624449
B97	1/8 x 3/8	1/8	105,000	5/25	3NQ80	69083149048	38A60-P	61463624451
B98	3/32 x 1/4	1/8	105,000	5/25			38A60-P	61463624452
B121	1/2" Ball	1/8	45,370	5/25			38A60-P	61463624466
B122	3/8" Ball	1/8	61,650	5/25	3NQ80	69083149050	38A60-P	61463624470
B122	3/8" Ball	1/8	61,650	5/25			38A90-Q	61463624471
B123	3/16" Ball	1/8	104,250	5/25			38A60-P	61463624472
B124	1/8" Ball	1/8	105,000	5/25			38A90-Q	61463624474
B131	1/2 x 1/2	1/8	34,500	5/25	3NQ80	69083149049	38A60-P	61463624475
B132	3/8 x 1/2	1/8	45,370	5/25			38A60-P	61463624479
B133	3/8 x 3/8	1/8	54,000	5/25			38A60-P	61463624481
B134	5/16 x 3/8	1/8	61,650	5/25			38A60-P	61463624482
B135	1/4 x 1/2	1/8	60,000	5/25			38A60-P	61463624484
B136	1/4 x 5/16	1/8	77,250	5/25			38A60-P	61463624485

† STANDARD SPINDLE SIZE IS 1/8" OR 1/4" X 1-1/2"
 * MAXIMUM OPERATING SPEED BASED ON 1/2" OVERHANG

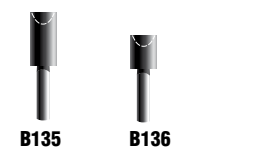
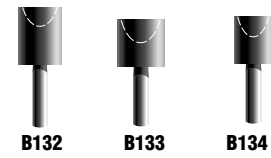
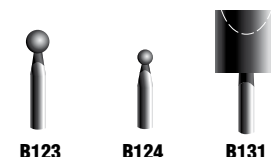
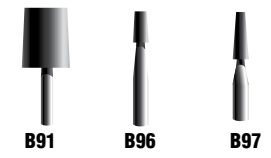
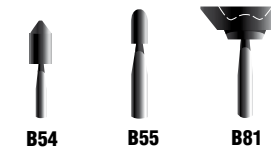
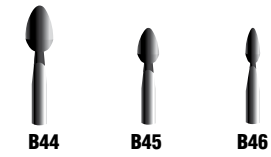
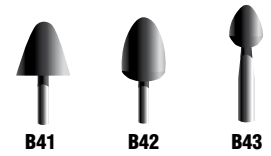



AVAILABILITY

TIER:	BEST	GOOD
BRAND:	Norton	Norton
TRADENAME:	QUANTUM	GEMINI
ABRASIVE:	Ceramic Alumina	38A

SHAPE	SIZE (D x T)	SPINDLE DIA. †	MAX. RPM*	MIN./STD. PKG.	SPEC	PART NO.	SPEC	PART NO.
Vitrified Bond Mounted Points – W Shapes								
W144	1/8 x 1/4	1/8	105,000	5/25			38A60-P	61463624488
W145	1/8 x 3/8	1/8	105,000	5/25			38A60-P	61463624489
W146	1/8 x 1/2	1/8	105,000	5/25			38A60-P	61463624491
W152	3/16 x 1/4	1/8	105,000	5/25			38A60-P	61463624495
W153	3/16 x 3/8	1/8	80,850	5/25			38A60-P	61463624496
W154	3/16 x 1/2	1/8	70,500	5/25	3NQ80	69083149133	38A60-P	61463624497
W160	1/4 x 1/4	1/8	81,370	5/25			38A60-P	61463624501
W162	1/4 x 3/8	1/8	64,800	5/25			38A60-P	61463624503
W163	1/4 x 1/2	1/8	60,000	5/25			38A60-P	61463624504
W164	1/4 x 3/4	1/8	45,900	5/25	3NQ80	69083149135	38A60-P	61463624505
W170	5/16 x 1/2	1/8	52,500	5/25			38A60-P	61463624511
W175	3/8 x 3/8	1/8	54,000	5/25			38A60-P	61463624516
W176	3/8 x 1/2	1/8	45,370	5/25			38A60-P	61463624517
W177	3/8 x 3/4	1/8	33,750	5/25			38A60-P	61463624518
W179	3/8 x 1-1/4	1/8	20,415	25/250	Oil & Gas 36	69083154055		
W185	1/2 x 1/2	1/8	34,500	5/25	3NQ80	69083149137	38A60-P	61463624525
W185	1/2 x 1/2	1/4	61,500	5/25			38A60-P	61463624526
W186	1/2 X 3/4	1/4	51,000	5/25			38A60-P	61463624528
W188	1/2 x 1-1/2	1/4	30,370	5/25			38A60-P	61463624530
W189	1/2 x 2	1/4	24,000	25/250	Oil & Gas 36	61463686137		
W189	1/2 x 2	1/4	24,000	5/25	3NQ80	61463677683	38A60-P	61463624531
W196	5/8 x 1	1/4	35,250	5/25			38A60-P	61463624539
W200	3/4 x 1/8	1/8	50,930	5/25			38A60-P	61463624543
W200	3/4 x 1/8	1/8	50,930	5/25			38A90-Q	61463624544
W204	3/4 x 3/4	1/4	42,750	5/25			38A60-P	61463624549
W205	3/4 x 1	1/4	34,500	5/25			38A60-P	61463624550
W208	3/4 x 2	1/4	18,750	5/25	3NQ80	61463677684	38A60-P	61463624553
W215	1 x 1/8	1/8	38,200	5/25	3NQ80	69083149138	38A60-P	61463624560
W216	1 x 1/4	1/4	38,200	5/25			38A60-P	61463624562
W218	1 x 1/2	1/4	38,200	25/250	Oil & Gas 36	69083154061		
W218	1 x 1/2	1/4	38,200	5/25			38A60-P	61463624564
W220	1 x 1	1/4	25,500	5/25	3NQ80	61463677685	38A60-P	61463624566
W221	1 x 1-1/2	1/4	19,120	5/25			38A60-P	61463624567
W222	1 x 2	1/4	15,900	5/25			38A60-P	61463624569
W230	1-1/4 x 1-1/4	1/4	20,400	5/25			38A60-P	61463624578
W235	1-1/2 x 1/4	1/4	25,470	5/25			38A60-P	61463624583
W236	1-1/2 x 1/2	1/4	25,470	5/25	3NQ80	61463677686	38A60-P	61463624585
W237	1-1/2 x 1	1/4	22,500	5/25			38A60-P	61463624587
W238	1-1/2 x 1-1/2	1/4	15,600	5/25			38A60-P	61463624588
W242	2 x 1	1/4	19,100	5/25			38A60-P	61463624592

† STANDARD SPINDLE SIZE IS 1/8" OR 1/4" X 1-1/2"

* MAXIMUM OPERATING SPEED BASED ON 1/2" OVERHANG

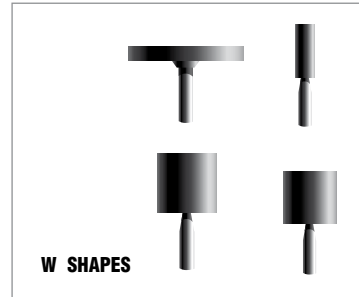

TECHtip

- For best mounted point performance, always run the mounted point at the maximum allowable speed according to ANSI B7.1. Refer to the speed chart included in each shipment for proper operating speeds.
- Use "A" shapes for medium- to heavy-duty blending.
- Use "B" shapes for light deburring and finishing/polishing.
- Use "W" shapes for offhand and precision grinding of medium to heavy stock.
- Use 36 grit and coarser for rough grinding.
- Use 60 and 90 grits for imparting fine finishes or when grinding on narrow surfaces.



It is the user's responsibility to refer to and comply with ANSI B7.1



50-Piece Mounted Point Kits

- Each kit contains 5 each of 10 of our best selling mounted point shapes and specifications
- The 1/4" spindle kits contain "A"-shaped points that are ideal for general maintenance and metalworking applications
- The 1/8" spindle kits contain "B"-shaped points for light deburring machine parts or finishing/polishing dies
- The "W"-shaped points in all of these kits work well for precision grinding of medium to heavy stock

TIER:	BEST	GOOD
BRAND:	Norton	Norton
TRADE NAME:	QUANTUM	GEMINI
	PART NO.	PART NO.

SHAPE	SPINDLE DIA. †	MIN./STD. PKG.		PART NO.	PART NO.
Mounted Point Kits					
Assorted	1/4	1	50 piece Premium Norton Quantum 1/4" Spindle Mounted Point Kit contains 5 each of A1, A5, A11, A21, A23, A26, A36, A39, W242 Norton Quantum and 5 W220 A80-HBF3	69083147810	
Assorted	1/8	1	50 piece Premium Norton Quantum 1/8" Spindle Mounted Point Kit contains 5 each of B42, B52, B97, B122, B131, W154, W164, W185, W215 Norton Quantum and W163 A80-HBF3	69083147806	
Assorted	1/4	1	50 piece 38A60-P 1/4" Spindle Gemini Mounted Point Kit contains 5 each of A1, A5, A11, A21, A23, A26, A36, A39, W242 Gemini and 5 W220 A80-HBF3		69083147789
Assorted	1/8	1	50 piece 38A60-P 1/8" Spindle Gemini Mounted Point Kit contains 5 each of B42, B52, B97, B122, B131, W154, W164, W185, W215 Gemini and W163 A80-HBF3		69083147669

† STANDARD SPINDLE SIZE IS 1/8" OR 1/4" X 1-1/2"



CATEGORY DEFINITION

Hard silicon carbide rubbing bricks are used for heavy-duty applications such as rubbing floors, cleaning and scouring castings, rubbing down concrete, and removing mold marks.

APPLICATIONS: Floor Rubbing Bricks – are used to rub down concrete and remove mold marks. These are designed to fit the chucks of common concrete floor grinding equipment. Reusable wooden wedges anchor the bricks to the equipment chucks.
 Plain Hand Rubbing Bricks – are the choice of mechanics and foundrymen for dressing grinding wheels and cleaning or scouring castings.
 Fluted Hand Rubbing Bricks – are used by masons and stone workers for rubbing down concrete and removing mold marks. The diagonal flutes provide sharp edges, a clean shearing action, and carry away debris.
 Fluted Hand Rubbing Bricks with Handle – make quick work of removing mold marks and rubbing down concrete. The firmly attached handle reduces fatigue and facilitates overhead, wall, and floor work.

GRIT RANGE: 6 – 120
ABRASIVE TYPE: Silicon Carbide



SIZE (L x W x H)	QTY./ PKG	QTY./ CASE	SPEC.	ABRASIVE	PRODUCT NO.	PART NO.
Plain Floor Rubbing Bricks with Wooden Wedges						
4 x 2 x 2	1	6	C6-R	Silicon Carbide		61463653292
			C10-R	Silicon Carbide		61463653293
			C24-R	Silicon Carbide		61463653294
			C80-R	Silicon Carbide		61463653295



SIZE (L x W x H)	QTY./ PKG	QTY./ CASE	SPEC.	ABRASIVE	PRODUCT NO.	PART NO.
Griddle Brick						
4-1/2 x 3 x 2	1	5	Medium	Alundum		61463687870



SIZE (L x W x H)	QTY./ PKG	QTY./ CASE	SPEC.	ABRASIVE	PRODUCT NO.	PART NO.
Floor Rubbing Brick with Center Score						
8 x 2 x 2	1	6	C120-R*	Silicon Carbide		61463685296*
*8" BRICK HAS A CENTER SCORE TO FACILITATE DIVIDING THE BRICK IN HALF – AN ECONOMICAL ALTERNATIVE TO BUYING TWO 4" BRICKS.						



SIZE (L x W x H)	QTY./ PKG	QTY./ CASE	SPEC.	ABRASIVE	PRODUCT NO.	PART NO.
Wooden Wedges						
	6	6				61463685297



SIZE (L x W x H)	QTY./ PKG	QTY./ CASE	SPEC.	ABRASIVE	PRODUCT NO.	PART NO.
Plain Hand Rubbing Bricks						
8 x 2 x 2	1	5	C24	Silicon Carbide	BP28	61463687830



SIZE (L x W x H)	QTY./ PKG	QTY./ CASE	SPEC.	ABRASIVE	PRODUCT NO.	PART NO.
Fluted Hand Rubbing Bricks						
6 x 2 x 2	1	5	C20	Silicon Carbide	BF26	61463687840
8 x 2 x 2	1	5	C20	Silicon Carbide	BF28	61463687845



SIZE (L x W x H)	QTY./ PKG	QTY./ CASE	SPEC.	ABRASIVE	PRODUCT NO.	PART NO.
Fluted Hand Rubbing Bricks with Handle						
6 x 3 x 1	1	5	C20	Silicon Carbide	BFH6	61463687800
8 x 3-1/2 x 1-1/2	1	5	C20	Silicon Carbide	235	61463687795



CATEGORY DEFINITION

Since 1823, Norton has been the leading supplier of sharpening and finishing products, delivering the superior performance you expect. Norton sharpening products include: benchstones, lubricants, abrasive files and slips, sharpening stations and systems, specialty and pocket stones.

- APPLICATIONS:** Deburring, dimensioning, sharpening, honing
- GRIT RANGE:** Coarse, Medium, Fine, Extra Fine, Ultra Fine
- ABRASIVE TYPES:** Aluminum Oxide (India), Silicon Carbide (Crystolon), Arkansas, Diamond

Retail Packaged Sharpening Products



AVAILABILITY

TIER: **BETTER**
 BRAND: Norton

SIZE	SPECIFICATION	QTY./ CASE	PART NO.
Abrasive Sharpening Stones			
Axe & Hatchet Sharpener			
3 x 5/8 round	Coarse/Fine Crystolon	10	07660785316
Pocket Knife Sharpener			
3 x 7/8 x 3/8 with case	Medium Aluminum Oxide	5	07660787937
3 x 1-1/2 x 1/2 with case	Coarse/Fine Aluminum Oxide	5	07660787630
Economy Tool & Knife Bench Stone			
6 x 2 x 3/4	Coarse/Fine Crystolon	5	07660787933
8 x 2 x 3/4	Coarse/Fine Aluminum Oxide	10	07660787934
High Quality Tool & Knife Bench Stone			
6 x 2 x 3/4	Coarse/Fine Crystolon	5	07660787935
Chisel & Planer Blade Sharpener			
8 x 2 x 3/4	Coarse/Fine India	10	07660787936
Household Knife & Tool Sharpener			
7-1/2	Fine Crystolon	5	07660787939
Farm Tool Sharpener			
10 x 1-1/4 x 3/4	Coarse Crystolon	10	07660787730
Lawn & Garden Tool Sharpener			
9-1/2 x 1-3/8 x 1/2	Medium Crystolon	10	07660787938
Sharpening Stone Oil			
4-1/2 oz.	Oil	5	07660787940



Rolling Wheel Knife Sharpener

The compact, handheld **Rolling Wheel Knife Sharpener** has two slots, to sharpen each side of the blade. It has a built-in proper angle for sharpening. No lubricant needed.

SPECIFICATION	QTY./CASE.	PART NO.
Slotted, handheld	12	66253092616



Knife and Scissors Sharpener

The **Knife and Scissors Mechanical Sharpener** is a quick and portable tool for hundreds of sharpening applications.

SPECIFICATION	QTY./CASE.	PART NO.
Carbide	6	07660787520



Bulk Sharpening Products

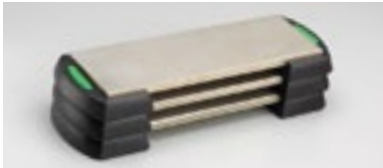

Faster and 100X the life of regular abrasives, **stackable diamond benchstones** provide quick, exceptional sharpening.

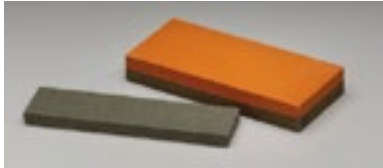

India benchstones produce a strong, keen, long-lasting edge on quality tools.

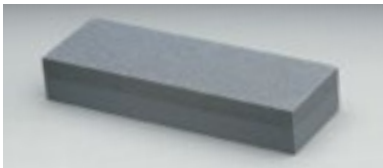

Crystolon benchstones are used for general sharpening when the speed of sharpening is more important than the fineness of the cutting edges.



Natural ozark quartz Arkansas benchstones create the finest finishes. White in color; may contain shades of red, yellow and gray.



Norton Oil is a highly refined lubricating oil and meets U.S. Pharmacopoeia standards for use around food preparation operations.



Tradesmen's Utility Stones are used for sharpening knives and as abrasive files in many different industries.

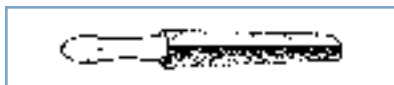

Utility File is designed for sharpening coarse cutting edges on cutting implements and edged garden tools.

AVAILABILITY

TIER: **BETTER**
 BRAND: Norton

SIZE (L x W x H)	SPECIFICATION	QTY./ CASE	PRODUCT NO.	PART NO.
Stackable Diamond Benchstones				
6 x 2 x 1/4	D220	5		66253268082
	D325			66253268081
	D600			66253268080
8 x 2 x 1	D220	5		66253268087
	D325			66253268086
	D600			66253268083
India (Aluminum Oxide) Single Grit Benchstones				
4 x 1 x 1/4	Coarse	5	CB14	61463685580
	Medium		MB14	61463685575
	Fine		FB14	61463685570
4 x 1 x 1/2	Coarse	5	CB24	61463685595
	Medium		MB24	61463685590
	Fine		FB24	61463685585
6 x 2 x 1	Coarse	5	CB6	61463685620
	Medium		MB6	61463685615
	Fine		FB6	61463685610
8 x 2 x 1	Coarse	5	CB8	61463685635
	Medium		MB8	61463685630
	Fine		FB8	61463685625
India (Aluminum Oxide) Combination Grit Benchstones				
4 x 1 Round	Coarse/Fine	5	IB64	61463685545
4 x 1-3/4 x 5/8	Coarse/Fine	5	IB134	61463685550
5 x 2 x 3/4	Coarse/Fine	5	IB45	61463685555
6 x 2 x 1	Coarse/Fine	5	IB6	61463685560
8 x 2 x 1	Coarse/Fine	5	IB8	61463685565
11-1/2 x 2-1/2 x 1	Coarse/Fine	2	IM2	61463685851
Crystolon (Silicon Carbide) Combination Grit Benchstones				
4 x 1 Round	Coarse/Fine	5	JB64	61463685435
4 x 1-3/4 x 5/8	Coarse/Fine	5	JB134	61463685440
5 x 2 x 3/4	Coarse/Fine	5	JB45	61463685445
6 x 2 x 1	Coarse/Fine	5	JB6	61463685450
8 x 2 x 1	Coarse/Fine	5	JB8	61463685455
11-1/2 x 2-1/2 x 1	Coarse/Fine	2	JUM3	61463685840
12 x 2-1/2 x 1-1/2	Coarse/Fine	2	JUM4	61463685855
Arkansas Single Grit Benchstones				
3 x 1 x 3/8	Extra Fine Soft Arkansas	10	SB13	61463687560
4 x 2 x 3/4-1	Extra Fine Soft Arkansas	5	SB4	61463685670
6 x 2 x 3/4-1	Extra Fine Soft Arkansas	5	SB6	61463685675
8 x 2 x 3/4-1	Extra Fine Soft Arkansas	5	SB8	61463685680
4 x 2 x 3/4-1	Ultra Fine Hard Arkansas	5	HB4	61463685655
6 x 2 x 3/4-1	Ultra Fine Hard Arkansas	5	HB6	61463685660
8 x 2 x 3/4-1	Ultra Fine Hard Arkansas	5	HB8	61463685665
Norton Oil				
4-1/2 oz.	Oil	20	XB1	61463687760
1 Pint	Oil	20	XB5	61463687770
1 Quart	Oil	5	XB2	61463687775
Tradesmen's Utility Stones – Crystolon (Silicon Carbide)				
14-3/4 including handle	Coarse/Fine	10	JT930	61463687675
14-3/4 including handle	Medium	10	JT920	61463687670
Utility File – Crystolon (Silicon Carbide)				
14 including handle	Coarse	10	JD2	61463687750





NORTON
SAINT-GOBAIN
BLAZE

NORTON
SAINT-GOBAIN
BLUEfire

MERIT



CATEGORY DEFINITION

The most heavy-duty of coated abrasive discs with resin over resin construction on heavy-duty vulcanized fiber backing. Designed for applications ranging from heavy stock removal to surface blending. Used with back-up pads on portable angle grinders.

APPLICATIONS:	Stock removal, edge chamfering, weld blending, deburring/deflashing, rust removal, cleaning and finishing
SIZE RANGE:	4" x 5/8" hole, 4-1/2" – 9-1/8" x 7/8" hole
GRIT RANGE:	16 – 120
ABRASIVE GRAIN:	Ceramic Alumina, Zirconia Alumina, Aluminum Oxide, Silicon Carbide
PRODUCT OPTIONS:	Speed-Change hubs (5/8-11"), AVOS technology
ACCESSORIES:	Air-cooled and smooth-faced back-up pads

MATERIAL-TO-PRODUCT RECOMMENDATION GUIDE

	BEST Highest Productivity – Lowest Total Cost	BETTER Excellent Blend of Performance & Price	GOOD Consistent Performance – Low Initial Price
Stainless Steel / Titanium / Super Alloys*	Norton Blaze F980	Norton BlueFire F826P	Merit Metal A/O
Mild Carbon Steel / Welds	Norton GreenLyte F968	Norton BlueFire F826P	Merit Metal A/O
Ferrous Metals / Cast Iron	Norton GreenLyte F968	Norton BlueFire F826P	Merit Metal A/O
Brass / Bronze / Aluminum	–	Norton Metalite F220	Merit Metal A/O
Paint / Glue / Stonework	–	Norton FastCut Silicon Carbide	Merit Metal A/O

*NICKEL/COBALT BASED – HASTELLOY, INCONEL, WASPALLOY

APPLICATION/GRIT RECOMMENDATION GUIDE

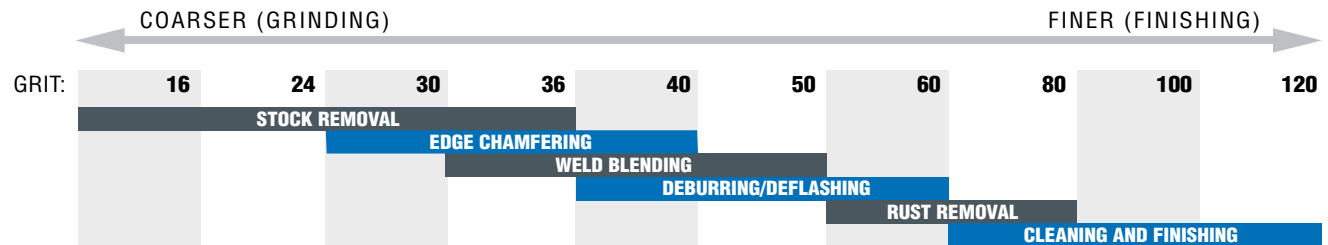

CROSS REFERENCE GUIDE

	TOTAL PERFORMANCE						INITIAL PRICE	
	BEST		BETTER				GOOD	
NORTON	Blaze F980	GreenLyte F968	BlueFire F826P		Metalite F220	Metalite F266		
MERIT			Ceramic	Z/A		Metal		
3M	985C, 982C	988C, 983C	785C	501C	–	280C	381C	281C GreenCorp
Camel	–	–	Ceramic Blend	–	Zirconia	A/O Open	–	A/O
Flexovit	–	–	Flexon CG	Flexon	–	–	Specialist	High Perf
GemTex	–	–	X, PMD	–	ZEE	SMD	–	A
Hermes	CB844X	CB444X/J	–	RB414X/J	–	–	RB314X/J	–
Klingspor	CS661	–	–	CS570	CS565	–	–	CS561
Metabo	–	–	–	–	Z/A	–	–	A
Mirka	–	–	–	Blue A/Z	Gold A/Z	–	–	Red A/O
Pearl	–	–	–	–	Zirconia	–	A/O Premium	A/O Silver
Pferd	CO Cool	CO	CO-PMD	Z Cool	Z	–	A Cool	A
Sait	9S	8S	–	3Z	Z	–	3A	A, 2A
SIA	–	4515	–	4815	4819	–	–	4919
Standard	–	–	Ceramic	–	Zirconia	–	A/O Extra	A/O
VSM	XF870	XF750	ZF844	ZF745	ZF713, ZF714	–	KF808	KF708
Walter	–	–	–	Topcut, Inox	–	–	Coolcut	–
Weiler	–	–	–	–	Zirconium	–	–	A/O



FEATURED PRODUCTS



NORTON BLAZE F980

BEST CHOICE FOR STAINLESS STEEL, TITANIUM, AND SUPER ALLOYS

FEATURES	BENEFITS
<ul style="list-style-type: none"> Patented, new generation ceramic alumina grain 	<ul style="list-style-type: none"> Improved micro-fracturing for sharper grain edges and improved grain life
<ul style="list-style-type: none"> Full-ratio / 100% ceramic alumina grain 	<ul style="list-style-type: none"> Significant cut rate and life over competitive blended/low-ratio ceramic alumina discs
<ul style="list-style-type: none"> Self-lubricating, advanced supersize treatment 	<ul style="list-style-type: none"> Minimizes heat, loading and glazing on stainless, titanium and super alloys
<ul style="list-style-type: none"> Improved resin bond system 	<ul style="list-style-type: none"> Improved grain retention for longer life
<ul style="list-style-type: none"> Extra heavy-duty backing on 50 grit and coarser 	<ul style="list-style-type: none"> Increased life and durability
<ul style="list-style-type: none"> Foil-packed availability 	<ul style="list-style-type: none"> Improved humidity and prevention against curl Fully recyclable for reduced landfill waste



NORTON GREENLYTE F968

BEST CHOICE FOR CARBON STEEL, WELDS, FERROUS METALS, AND CAST IRON

FEATURES	BENEFITS
<ul style="list-style-type: none"> Premium, patented, self-sharpening full-ratio ceramic abrasive grain 	<ul style="list-style-type: none"> Faster initial cut rate, longer life and improved finishes versus competitive ceramic



NORTON BLUEFIRE F826P

BETTER CHOICE FOR STAINLESS, SUPER ALLOYS, STEEL, CAST IRON AND HIGH PRESSURE APPLICATIONS

FEATURES	BENEFITS
<ul style="list-style-type: none"> New, improved blend of patented ceramic alumina and zirconia alumina abrasive 	<ul style="list-style-type: none"> 15% faster cut and longer life with less power draw Broad utility on a wide range of materials



NORTON METALITE F220

BETTER CHOICE FOR SOFT METALS

FEATURES	BENEFITS
<ul style="list-style-type: none"> High-performance aluminum oxide 	<ul style="list-style-type: none"> Low initial price with consistent performance
<ul style="list-style-type: none"> Paraffin wax coating 	<ul style="list-style-type: none"> Minimizes loading without sacrificing life, while providing excellent cut Reduces heat at the point of contact, so disc remains free-cutting and Less pressure required for optimum performance

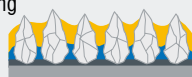

MERIT METAL

GOOD STARTING SPECIFICATION FOR ALL METALS

FEATURES	BENEFITS
<ul style="list-style-type: none"> High-performance aluminum oxide 	<ul style="list-style-type: none"> Low initial price with consistent performance



AVAILABILITY



TIER:	BEST	BEST	BETTER	BETTER	BETTER
BRAND:	Norton	Norton	Merit	Norton	Merit
TRADENAME:	BLAZE F980	GREENLYTE F968	CERAMIC	BLUEFIRE F826P	ZA
ABRASIVE:	Ceramic Alumina	Ceramic Alumina	Ceramic Alumina	Ceramic/Zirconia	Zirconia Alumina
OTHER:	Supersize				

SIZE (D x H)	GRIT	STD. PKG.	PART NO.	PART NO.	PART NO.	PART NO.	PART NO.
4-1/2 x 7/8	24	25	69957398000	66261141313	66623355601	66261138457	66623353315
	36		69957398001	66261141312	66623355602	66261138456	66623353316
	50		69957398002	66261141311	66623355603	66261138454	66623353318
	60		69957398003	66261141310	66623355604	66261138453	66623353319
	80		69957398004	66261141309	66623365598	66261138452	66623353320
	100			66261141308			
	120		66254425332	66261141307			
5 x 7/8	24	25	69957398005	66261141320	66623355597	66261138563	66623357290
		50	66254464822#				
	36	25	69957398006	66261141319	66623355598	66261138562	66623357291
		50	66254464821#				
	50	25	69957398007	66261141318	66623355599	66261138561	66623357292
		50	66254464820#				
	60	25	69957398008	66261141317	66623355600	66261138601	66623357293
80	25	69957398009	66261141316	66623366015	66261138600	66623357294	
100	25		66261141315				
120	25	66254409084	66261141314				
7 x 7/8	24	25	69957398010	66261141327	66623355578	66261138594	66623357295
	36	25	69957398011	66261141326	66623355594	66261138593	66623357296
	50	25	69957398012	66261141325	66623355595	66261138592	66623357297
	60	25	69957398013	66261141324	66623355596	66261138591	66623357298
	80	25	69957398014	66261141323	66623365600	66261138590	66623357299
	100	25		66261141322			
	120	25	66254411528	66261141321			
9-1/8 x 7/8	24	25	69957398015	66261141344	05539510782	66261138584	
	36		69957398016	66261141343	05539510749	66261138583	
	50		69957398017		05539510748	66261138582	
	60			66261141341			
	80			66261141340			
	100			66261141339			

SHRINK-WRAP FOIL PACK: 10 DISCS PER PACK, 5 PACKS PER STANDARD PACKAGE

NOTE: FIBER DISCS MUST ALWAYS BE USED WITH BACK-UP PADS, SHOWN ON THE LAST PAGE OF THIS SECTION

For All Your Right Angle Grinding and Blending Applications



NORTON BLAZE PLUS

Latest generation ceramic alumina abrasive provides the industry's fastest cutting discs and 50-200% longer life on stainless, titanium, and super alloys.

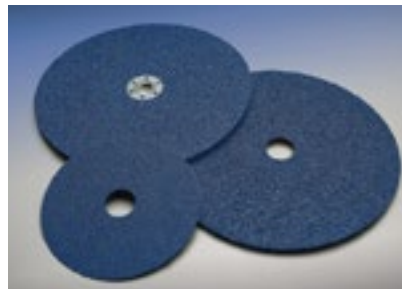

NORTON BLUEFIRE

New ceramic/zirconia abrasive blend for an increased cut rate and longer life over conventional zirconia products on high pressure applications.



MERIT METAL

High-performance aluminum oxide product provides the best starting specification when price is primary consideration.



AVAILABILITY



TIER:	BETTER	GOOD	GOOD
BRAND:	Norton	Norton	Merit
TRADENAME:	METALITE F220	METALITE F226	METAL
ABRASIVE:	Aluminum Oxide	Aluminum Oxide	Aluminum Oxide
OTHER:	Paraffin Fill		

SIZE (D x H)	GRIT	STD. PKG.	PART NO.	PART NO.	PART NO.
4 x 5/8	24	25		66261133434	05539510595
	36			66261133433	05539510594
	50			66261133432	05539510593
	60			66261133431	05539510592
	80			66261133430	05539510591
	100			66261133429	
	120			66261133428	
4-1/2 x 7/8	24	25	66254400694	66261133519	66623353309
	36			66261133517	66623353306
	50			66261133515	66623353310
	60			66261133513	66623353311
	80			66261133511	66623353312
	100			66261133509	66623353313
	120			66261133507	66623353314
5 x 7/8	16	25	66254400692	66261133617	05539510684
	24			66261133615	66623357276
	36			66261133610	66623357277
	50			66261133605	66623357278
	60			66261133600	66623357279
	80			66261133595	66623357280
	100			66261133590	66623357281
	120			66261133585	66623357282
7 x 7/8	16	25	66254400702	66261133760	05539510693
	24			66261133755	66623357283
	36			66261133750	66623357284
	50			66261133745	66623357285
	60			66261133740	66623357286
	80			66261133735	66623357287
	100			66261133730	66623357288
	120			66261133725	66623357289
9-1/8 x 7/8	16	25		66261133890	
	24			66261133885	05539510702
	36			66261133880	05539510701
	50			66261133875	
	60			66261133870	05539510699
	80			66261133865	
	120			66261133860	
			66261133855	05539510695	

** 10 PER STD. PKG.

NOTE: FIBER DISCS MUST ALWAYS BE USED WITH BACK-UP PADS, SHOWN ON THE LAST PAGE OF THIS SECTION

FastCut Fiber Discs

Type 27 (flat-faced), semi-rigid fiber-backed discs with extra sharp, coarse 16 grit silicon carbide abrasive, are engineered specifically with cooling ridges for an interrupted cut to efficiently grind softer materials (marble, granite, concrete, etc.) where loading is a problem. Quickly penetrates and removes any coatings such as adhesives, paint, acrylics, mastics, etc.

COOLING RIDGES MINIMIZE LOADING TO REMAIN FREE-CUTTING AND LAST LONGER.

AVAILABILITY

TIER:	BETTER
BRAND:	Norton
TRADENAME:	FASTCUT TYPE 27
ABRASIVE:	Silicon Carbide
OTHER:	Semi-Rigid

SIZE (D x H)	GRIT	STD. PKG.	PART NO.
4-1/2 x 7/8	16	25	66261199054
7 x 7/8	16	25	66261199052

NOTE: FASTCUT DISCS MUST BE USED WITH BACK-UP PADS ABOVE





Speed-Change Discs

These fiber discs feature Norton quick, tool-free, twist-on and off Speed-Change fasteners. Discs lock to standard back-up pads with a unique nut design and are easily removed, increasing your productivity with more time to grind.

AVAILABILITY

SIZE (D x H)	GRIT	STD. PKG.	PART NO.	PART NO.	PART NO.
4-1/2 x 5/8-11 Speed-Change	24	25	66261023269		
	36		66261185294		
5 x 5/8-11 Speed-Change	24	25	66254425336	66261138797	
	36		66261185801	66261138796	66261137522
	60				66261137515
7 x 5/8-11 Speed-Change	24	25	69957349782	66261138819	66261137625
	36		66261029863	66261138818	66261137620
	50			66261138817	66261137615
	60			66261138816	
	80				66261137605
	100				66261137600
	120			66261137595	

NOTE: SPEED-CHANGE FIBER DISCS MUST ALWAYS BE USED WITH BACK-UP PADS, SHOWN ON THE LAST PAGE OF THIS SECTION

AVOS Fiber Discs and Speed-Lok Back-up Pads

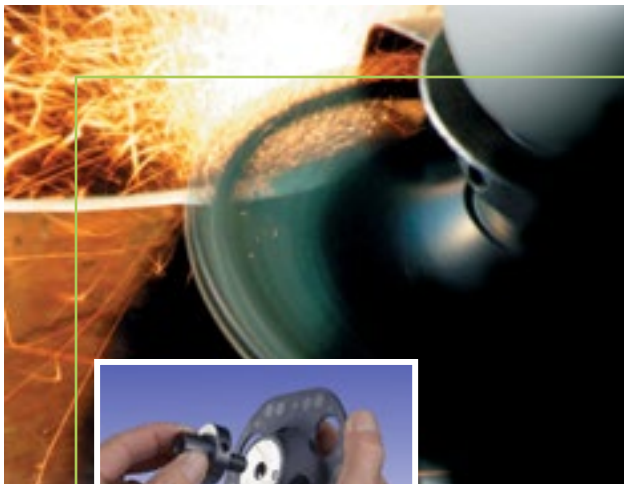

- Patented, see-through design allows interrupted cut which reduces heat up to 30% over standard discs
- The scooped holes create air flow to pull swarf away from grinding zone; cool cutting and extended product life
- 5" back-up pad for full utilization of discs – no gouging
- Quick, tool-free, twist-on and off Speed-Lok fasteners

AVAILABILITY

SIZE	MAX RPM	STD PKG.	PART NO.
AVOS Triangular Speed-Lok Back-up Pads			
4-1/2" x 5/8-11	13,000	5	63642502985
5" x 3/8-24 Pistol Grip*	20,000	5	63642503029
5" x 5/8-11	13,000	5	63642502517
5" x 7/16-20 Pistol Grip*	20,000	5	63642503030
AVOS Round Speed-Lok Back-up Pads			
7" x 5/8-11 Hard	8,600	5	63642504873
7" x 5/8-11 Medium	8,600	5	63642504874

*USE ON AIR PNEUMATIC AND HIGH-SPEED PISTOL GRIP SANDERS

SIZE	GRIT	STD. PKG.	PART NO.	PART NO.
4-1/2" Speed-Lok (3 hole)	24	10	66254468389	66261129718
	36		66254468390	66261129719
	50		66254468391	66261129720
	60		66254468392	66261129721
	80		66254468393	66261129722
5" Speed-Lok (3 hole)	24	10	66254468385	66261126556
	36		66254468386	66261126557
	50		66254468387	66261126558
	60		66254468388	66261126559
	80			66261126560
7" Speed-Lok (6 hole)	24	10	66254468381	66261137454
	36		66254468382	66261137455
	50		66254468383	66261137456
	60		66254468384	66261137457
	80			66261137458

NOTE: AVOS FIBER DISCS MUST BE USED WITH AVOS SPEED-LOK BACK-UP PADS SHOWN AT LEFT



Air-Cooled Standard Back-up Pad

Slotted hub design and curved ribs draw heat away from the grinding zone, reducing disc loading and increasing life. All pads have a 5/8"-11 threaded female hub for mounting. We also offer a no-nose for shorter-shafted right angle grinders.



Smooth Face Speed-Change Back-up Pad

Molded rubber back-up pads with a smooth face.

- Hard density pads are for aggressive cutting action
- Medium density pads are for all-purpose applications
- Soft density pads are used for contours and fine finishing work

Fiber Disc Accessories

DESCRIPTION	MAX. RPM	STD. PKG.	PART NO.
Rubber Back-up Pads			
Air Cooled Standard			
4" Medium	12,000	5	63642504918
4-1/2" Medium	11,000	5	63642502122
5" Medium	10,000	5	63642543421
7" Hard	8,600	5	63642543425
7" Medium	8,600	5	63642543422
9" Hard	6,600	5	63642543426
9" Medium	6,600	5	63642543423
NOTE: RETAINER NUTS ARE NOT INCLUDED WITH BACK-UP PADS. THESE MUST BE ORDERED SEPARATELY.			
Air Cooled No-Nose			
4-1/2" Medium	11,000	5	63642504872
5" Medium	10,000	5	63642503000
7" Medium	8,600	5	66254487375
Smooth Face / Speed-Change			
4-1/2" Medium	20,000	5	66254492277
5" Medium	12,000	5	63642543235
7" Hard	8,600	5	63642543240
7" Medium	8,600	5	63642543245
7" Soft	8,600	5	63642543250
9" Medium	7,000	5	63642543270
Tools			
#103 Retainer Nut	—	10	63642543463
Spanner Wrench	—	5	63642543005
66NS Short Retainer Nut	—	10	63642543461





NORTON
SAINT-GOBAIN
BLAZE

NORTON
SAINT-GOBAIN
BLUEfire

NORTON
SAINT-GOBAIN
NEON

NORTON
SAINT-GOBAIN
REDHEAT

MERIT



CATEGORY DEFINITION

Flap discs are versatile grinding and finishing tools, consisting of three main components: a backing plate, adhesive, and abrasive cloth flaps. The rectangular flaps are overlapped and glued to the backing plate. Flap discs are designed for right angle grinder applications ranging from heavy stock removal to surface blending.

APPLICATIONS:	Grinding, stock removal, edge chamfering/beveling, weld blending, deburring/deflashing, rust removal, blending, cleaning and finishing
SIZE RANGE:	4": 5/8" hole 4-1/2" - 7": 5/8"-11 discard mount and 7/8" hole
GRIT RANGE:	24 – 120
ABRASIVE GRAIN:	Ceramic Alumina, Zirconia Alumina, Aluminum Oxide, Silicon Carbide
ABRASIVE FLAPS:	Polyester or cotton
FLAP DISC SHAPE:	Type 27 Flat and Type 29 Conical
ABRASIVE FLAP DENSITY:	Standard or high
BACKING PLATE MATERIAL:	Fiberglass, plastic or aluminum

FLAP DISC SHAPES



GRIND AT FLATTER ANGLES:
0° – 15°

Type 27 Flat – The Best Choice for Finishing

- Used primarily on flat surfaces
- The best choice for blending and smooth finishing

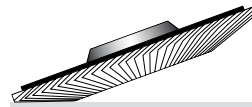

GRIND AT STEEPER ANGLES:
15° – 25°

Type 29 Conical – The Best Choice for Aggressive Stock Removal

- Conical flap discs have angled flaps and may be used on both contoured and edge work
- The angle provides greater surface contact for stock removal on flat surfaces
- The best choice when speed and stock removal are primary considerations

ABRASIVE FLAP DENSITIES



Standard Density

- Excellent for heavy-duty applications and rapid stock removal



High Density

- Ideal when working on uneven or curved surfaces, as well as finer grit blending

BACKING PLATE MATERIALS

All flap discs are a combination of abrasive flaps adhered to a rigid backing plate. It is the backing plate that provides stability during operation. There are three main materials used: fiberglass, plastic or aluminum. The fiberglass backing plate, along with the flap shape, helps to absorb vibration and is consumed during use with no smearing. Fiberglass is the most popular material because of its high strength and light weight. The plastic backing plate offers some additional conformability and is trimmable. The aluminum backing plate provides extra high strength and rigid support as needed. While not consumable during use, an aluminum plate can be recycled.

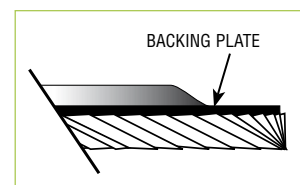

WHY CHOOSE FLAP DISCS?

Flap discs replace both grinding wheels and fiber discs. The same flap disc can be used for applications ranging from stock removal to blending.

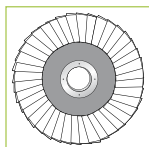

Flap Discs vs. Grinding Wheels

- Faster stock removal
- Smoother finish, no gouging
- Cooler cutting, less glazing
- Lightweight, easier to control
- Less vibration, less operator fatigue
- Reduced noise

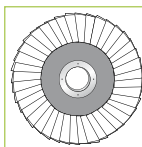
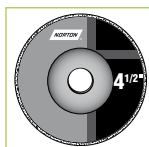

Flap Discs vs. Fiber Discs

- 20X longer life, reduced abrasive cost
- Fewer disc changes, reduced labor cost
- More consistent finish
- No back-up pad required
- Easier storage, no curling
- Reduced loading
- Use flap discs one grit size coarser than fiber discs, except in 36 grit.

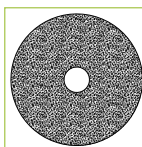



MATERIAL-TO-PRODUCT RECOMMENDATION GUIDE

BEST Highest Productivity – Lowest Total Cost	BETTER Excellent Blend of Performance & Price	GOOD Consistent Performance – Lowest Total Cost
--	--	--

Type 29 for Stock Removal

Material	Best	Better	Good
Stainless Steel / Titanium / Super Alloys	Norton Blaze R980P	Norton BlueFire R884P	Merit Metal
Mild Carbon Steel / Welds	Norton Red Heat R961	Norton BlueFire R884P	Merit Metal
Ferrous Metals / Cast Iron	Norton Red Heat R961	Norton BlueFire R884P	Merit Metal
Brass / Bronze / Aluminum	–	Norton BlueFire R884P	Merit Silicon Carbide
Paint / Glue / Adhesive	–	–	Merit Silicon Carbide
Concrete / Stone / Fiberglass	–	–	Merit Silicon Carbide

Type 27 for Blending and Finishing

Material	Best	Better	Good
Stainless Steel / Titanium / Super Alloys	Norton Blaze R980P	Norton BlueFire R884P	Merit Metal
Mild Carbon Steel / Welds	Norton Red Heat R961	Norton BlueFire R884P	Merit Metal
Ferrous Metals / Cast Iron	Norton Red Heat R961	Norton BlueFire R884P	Merit Metal
Brass / Bronze / Aluminum	–	Norton BlueFire R884P	Merit Metal

APPLICATION/GRIT RECOMMENDATION GUIDE

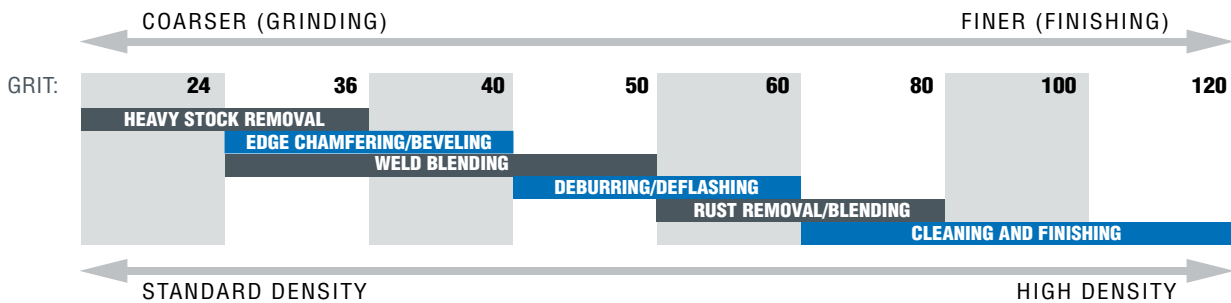

CROSS REFERENCE GUIDE



	BEST		BETTER	GOOD	
	Blaze R980P	Red Heat R961	BlueFire R884P	Neon R766 Metal / Zirconia	Silicon Carbide
NORTON					
MERIT					
3M	947D	747D	563D, 546D	–	–
DeWalt	–	–	–	Z/A	–
Camel	–	C3	Z-Stainless	Z3, A3	SC
Flexovit	–	–	–	Zircotex Premium, Zircotex HP	–
Garryson	–	–	Zirc+, Zirconium	Aluminum Oxide	–
GemTex	–	Ceramic	–	Zirconia, A/O	–
Hermes	–	–	–	–	–
Klingspor	–	–	SMT 630	SMT 618, 619, 624, 626, 627, 628, 640	–
Metabo	–	–	–	Z/A	–
Pearl	–	Stainless Max	Zirconia Premium, TuffMax	Z/A Silver Line, Premium A/O Classic, Silver Line	SC
Pferd	–	Ceramic	Cool Zirconia, CO-COOL	Zirconia, Cool Aluminum Oxide, Aluminum Oxide	Masonry Silicon Carbide
Sait	–	–	Z	2A, 3A	–
SIA	–	–	–	Z/A	–
Standard	–	Ceramic Oxide	Zirconia Pro	Zirconia	–
Tyrolit	–	–	Z/A	A/O	–
Walter	–	–	Enduro Flex	–	–
Weiler	–	Saber Tooth Ceramic	–	Tiger Zirconium, A/O, Vortec	–



FEATURED PRODUCTS



NORTON BLAZE R980P

BEST/HIGHEST PRODUCTIVITY FOR STAINLESS STEEL, TITANIUM, AND SUPER ALLOYS

FEATURES	BENEFITS
■ Latest-generation ceramic alumina abrasive grain	■ Last 50% – 200% longer than any flap discs on stainless steel, cobalt, chrome, Inconel, titanium and other hard-to-grind materials
■ Supersize grinding aid	■ Cool, noticeably fast cut rate
■ Y-weight polyester flaps	■ Significantly improve life, grain retention and fray resistance
■ Durable fiberglass back	■ High strength, lightweight, absorbs vibration
■ Orange, flexible plastic backing plate on Type 27 Quick Trim	■ New industry standard for trimmability



NEW

NORTON RED HEAT R961

BEST/HIGH PRODUCTIVITY FOR MILD CARBON STEEL, AND FERROUS METALS

FEATURES	BENEFITS
■ New, premium ceramic and zirconia alumina abrasive blend	■ Excellent performance and efficiencies on mild carbon steel and ferrous metal/cast iron applications
■ Durable, fiberglass back (Type 29)	■ High strength, lightweight, absorbs vibration
■ Red, flexible plastic backing plate on Type 27 Quick Trim	■ New industry standard for trimmability



IMPROVED

NORTON BLUEFIRE R884P

BETTER CHOICE FOR MILD CARBON STEEL, AND WELD

FEATURES	BENEFITS
■ High performance zirconia alumina plus abrasive	■ Aggressive cut and long life
■ Polyester flaps	■ Up to 30% longer life than competitive zirconia alumina products
■ Semi-open coat	■ Improved durability
■ Durable, fiberglass back	■ Retards loading on aluminum
■ Blue, flexible plastic backing plate on Type 27 Quick Trim	■ High strength, lightweight, absorbs vibration
	■ New industry standard for trimmability



NEW

NORTON NEON R766

GOOD CHOICE FOR ALUMINUM, BRASS, BRONZE, STAINLESS, CARBON STEEL, AND TITANIUM

FEATURES	BENEFITS
■ Alternating aluminum oxide (green) and zirconia alumina (blue) flaps	■ Ideal when purchasing criteria is a good-performing, economically-priced, general purpose disc
■ New resin system and Y-wt. polyester flaps	■ Improved base adhesion and 30%+ improvement in life over key competitors' aluminum oxide flap discs
	■ Stand up on light- to moderately-demanding applications
■ New grain coating	■ Longer life and faster cut rate
■ Type 29, Type 27 HD; fiberglass back	■ High strength, lightweight, absorb vibration
■ Green, flexible plastic backing plate on Type 27 Quick Trim	■ New industry standard for trimmability



MERIT METAL

GOOD CHOICE FOR STAINLESS STEEL, CAST IRON, AND ALUMINUM

FEATURES	BENEFITS
■ Quality zirconia alumina abrasive	■ Good cut rate and life
	■ Type 29 for hard to grind materials; Type 27 for softer materials
■ Engineered blend of X-weight cotton and Y-weight polyester flaps	■ Longer life and wear resistance
■ Durable, fiberglass back	■ High strength, lightweight, absorbs vibration
■ Competitive initial price point	■ Best starting specification for end-user unable to measure performance



AVAILABILITY

TIER:	BEST	BEST	BEST	BEST	BEST
BRAND:	Norton	Norton	Norton	Norton	Norton
TRADENAME:	BLAZE R980P	BLAZE R980P	BLAZE R980P	RED HEAT R961	RED HEAT R961
SHAPE:	Type 27 Flat	Type 27 Flat	Type 29 Conical	Type 27 Flat	Type 29 Conical
FLAP DENSITY:	Standard	High	Standard	Standard	Standard
ABRASIVE:	Ceramic Alumina	Ceramic Alumina	Ceramic Alumina	Ceramic Alumina/ Zirconia Alumina	Ceramic Alumina/ Zirconia Alumina
BACKING PLATE:	Quick Trim Plastic	Fiberglass	Fiberglass	Quick Trim Plastic	Fiberglass
OTHER:	Supersize	Supersize	Supersize		

SIZE (D x H)	GRIT	MAX. RPM	STD. PKG	PART NO.	PART NO.	PART NO.	PART NO.	PART NO.
4 x 5/8	40	15,300	10				63642536153	
	60					63642536154		
	80					63642536155		
4-1/2 x 5/8-11	36	13,300	10		66254499894	66261183490	66623399163•	66623399053•
	40			66254400257	66261098290	66261183491	63642536147•	63642536156•
	60			66254400258	66261096435	66261183492	63642536148•	63642536157•
	80			66254400259	66261096436	66261183493	63642536149•	63642536158•
	120			66254400261			66623399164•	63642597115•
4-1/2 x 7/8	36	13,300	10		66261097678	66261183486	63642504876	63642504329
	40			66254400253	66261020628	66261183487	63642504877	63642504330
	60			66254400254	66261020633	66261183488	63642504878	63642504331
	80			66254400255	66261020634	66261183489	63642504879	63642504332
	120			66254400256			63642505279	63642504333
5 x 5/8-11	36	12,000	5				66623399165	66623399197
	40					66254491941	66623399198	
	60					66254491942	66623399199	
	80					66254491943	66623399200	
	120					66623399166	66623399201	
5 x 7/8	36	12,000	10			66261190001	63642505281	66623399054
	40			66254400262	66261190002	63642505282	66623399055	
	60			66254400264	66261190003	63642505283	66623399056	
	80			66254400265	66261190004	63642505284	66623399057	
	120			66254400519			63642505285	66623399202
6 x 5/8-11	40	10,200	5				66623399167	
	60					66623399168		
	80					66623399169		
6 x 7/8	40	10,200	10				66623399024	63642541406
	60					66623399025	63642541407	
	80					66623399026	63642541408	
	120					66623399027		
7 x 5/8-11	36	8,600	10		66261183498	66623399170•	66623399058•	
	40			66254461066	66261183499	63642536150•	63642536159•	
	60			66254461067	66261183500	63642536151•	63642536160•	
	80			66254461068	66261183501	63642536152•	63642536161•	
	120			66254461069			66623399171•	66623399203•
7 x 7/8	36	8,600	10		66261183494	63642504880	63642504880	63642504334
	40			66254461059	66261183495	63642504881	63642504335	
	60			66254461060	66261183496	63642504882	63642504336	
	80			66254461061	66261183497	63642504883	63642504337	
	120			66254461063			66623399172	63642504338

• 5/8-11 (HUBBED) RED HEAT FLAP DISC STD. PKG. QUANTITY = 5



New Trimmable, Flexible Plastic Backing Plate

Quick Trim Norton Blaze R980P and Norton Red Heat R961 Flap Discs

New higher-performance abrasive flaps are mounted on our new flexible, easily-trimmable plastic backing plate. To fully use the flaps, the new Quick Trim flap discs are the answer. Available in 7/8" hole or our industry standard 5/8-11 mini mount that ensures maximum safety for all right angle grinders.



AVAILABILITY

				BETTER	BETTER	GOOD	GOOD	GOOD
				Norton	Norton	Norton	Norton	Norton
				BLUEFIRE R884P	BLUEFIRE R884P	NEON R766	NEON R766	NEON R766
				Type 27 Flat	Type 29 Conical	Type 27 Flat	Type 27 Flat	Type 29 Conical
				Standard	Standard	Standard	High	Standard
				Zirconia Alumina Plus	Zirconia Alumina Plus	Aluminum Oxide/ Zirconia Alumina	Aluminum Oxide/ Zirconia Alumina	Aluminum Oxide/ Zirconia Alumina
				Quick Trim Plastic	Fiberglass	Quick Trim Plastic	Fiberglass	Fiberglass
SIZE (D x H)	GRIT	MAX. RPM	STD. PKG.	PART NO.	PART NO.	PART NO.	PART NO.	PART NO.
4 x 5/8	36	15,300	10		66623399049			
	40			66623399050				
	60			66623399051				
	80			66623399052				
4-1/2 x 5/8-11	36	13,300	10	66623399136	66254461165	66623399125	66623399205	66623399028
	40			66623399137	66254461167	66623399000	66623399059	66623399029
	60			66623399138	66254461170	66623399001	66623399060	66623399030
	80			66623399139	66254461173	66623399002	66623399061	66623399173
	120				66623399003		66623399174	
4-1/2 x 7/8	24	13,300	10		66623399204			
	36			66623399140	66254461155	66623399126	66623399062	66623399032
	40			66623399141	66254461161	66623399004	66623399063	66623399033
	60			66623399142	66254461163	66623399005	66623399064	66623399034
	80			66623399006	66623399065	66623399035	66623399035	
	120			66623399007			66623399175	
5 x 5/8-11	36	12,000	10	66623399144	66623399189	66623399127	66623399207	66623399176
	40			66623399145	66623399190	66623399128	66623399208	66623399177
	60			66623399146	66623399191	66623399130	66623399209	66623399178
	80			66623399147	66623399192	66623399131	66623399210	66623399179
	120			66623399132			66623399180	
5 x 7/8	24	12,000	10		66623399206			
	36			66623399148	66254461174	66623399133	66623399211	66623399036
	40			66623399149	66254461176	66623399008	66623399212	66623399037
	60			66623399150	66254461177	66623399009	66623399213	66623399038
	80			66623399010	66623399214	66623399039	66623399039	
	120			66623399011			66623399181	
6 x 5/8-11	40	10,200	10				66623399219	66623399040
	60					66623399220	66623399041	
	80					66623399221	66623399042	
6 x 7/8	24	10,200	10		66623399066			
	36				66623399298		66623399215	
	40			66623399152	66623399193	66623399012	66623399216	66623399182
	60			66623399153	66623399194	66623399013	66623399217	66623399183
	80		66623399154	66623399195	66623399014	66623399218	66623399184	
	120			66623399015				
7 x 5/8-11	36	8,600	10	66623399155	66254461188	66623399134	66623399222	66623399185
	40			66623399156	66254461190	66623399016	66623399067	66623399043
	60			66623399157	66254461192	66623399017	66623399068	66623399044
	80			66623399158	66254461193	66623399018	66623399069	66623399045
	120			66623399019			66623399186	
7 x 7/8	24	8,600	10		66623399196			
	36			66623399159	66254461180	66623399135	66623399070	66623399187
	40			66623399160	66254461183	66623399020	66623399071	66623399046
	60			66623399161	66254461185	66623399021	66623399072	66623399047
	80			66623399022	66623399073	66623399048	66623399048	
	120			66623399023			66623399188	



AVAILABILITY

				GOOD	GOOD	GOOD	GOOD
TIER:				Merit	Merit	Merit	Merit
BRAND:				Metal	Metal	Zirconia	Silicon Carbide
TRADENAME:				Metal	Metal	Zirconia	Silicon Carbide
SHAPE:				Type 27 Flat	Type 29 Conical	Type 29 Conical	Type 29 Conical
FLAP DENSITY:				Standard	Standard	High	Standard
ABRASIVE:				Zirconia Alumina	Zirconia Alumina	Zirconia Alumina	Silicon Carbide
BACKING PLATE:				Fiberglass	Fiberglass	Fiberglass	Fiberglass
SIZE (D x H)	GRIT	MAX. RPM*	STD. PKG.	PART NO.	PART NO.	PART NO.	PART NO.
4-1/2 x 5/8-11	36	13,300	10	66254472655	66254419991	08834194447*	
	40			66254437013	66254419994	08834193906*	
	60			66254472656	66254419996	66261044504*	66254460664
	80			66254472657	66254419997	66261044505*	08834196277
	120					66261044506*	08834196275
4-1/2 x 7/8	24	13,300	10			08834194833*	
	36			66254472653	66254419963	08834191427*	
	40			66254437004	66254419978	08834190726*	
	60			66254448989	66254419984	08834190175*	66254460663
	80			66254448990	66254419987	08834190924*	08834195676
	120				08834190995*	08834195677	
5 x 7/8	36	12,000	10	66254472659	66254419998		
	40			66254472660	66254420001		
	60			66254472661	66254420002	08834190876	66254460694
	80			66254472662	66254420003	08834190405	66254460463
	120					08834192209	66254460464
6 x 5/8-11	40	10,200	10	66254491773	66254491779		
	60			66254491774	66254491780		
	80			66254491775	66254491781		
6 x 7/8	40	10,200	10	66254491770	66254491776		
	60			66254491771	66254491777		
	80			66254491772	66254491778		
7 x 5/8-11	36	8,600	10	66254472669	66254420009	08834193830	
	40			66254472670	66254420010	66261044540	
	60			66254472671	66254420012	08834199751	66254460666
	80			66254472672	66254420013	08834192896	08834197186
	120					66261044541	08834197187
7 x 7/8	24	8,600	10			08834190877	
	36			66254472664	66254420004	08834190878	
	40			66254472665	66254420006	08834192059	
	60			66254472666	66254420007	08834196985	66254460665
	80			66254472667	66254420008	08834196986	08834195705
	120				08834196988	66254460462	

* MAX RPM FOR MERIT ZIRCONIA HIGH DENSITY FLAP DISCS IS 13,000

When You Want Fast and Tough, You Want Norton

Whether you want maximum productivity or simply the lowest initial cost solution, Norton has the product for all your right angle grinding and blending applications.



BEST Norton Blaze

Highest Productivity – Lowest Total Cost

Latest-generation ceramic alumina abrasive provides the industry's fastest cutting discs and 50-200% longer life over any flap disc on stainless, titanium, and super alloys.



BETTER Norton BlueFire

Exceptional Blend of Performance and Price

New zirconia alumina plus abrasive for an increased cut rate and up to 30% longer life over conventional zirconia products on carbon steel and welds.



GOOD Norton Neon

Good Performance – Low Initial Price

30%+ life vs. competitive aluminum oxide products. Ideal for soft metals to hard-to-grind stainless and carbon steel – and light-to-moderately-demanding applications



NorZon 20X High Performance

- Zirconia alumina abrasive disc, packaged for retail/walk-in selling
- Individual hang card provides product selling points
- Product ships in merchandisable display case of small quantities



TIER: **BEST**

BRAND: Norton

TRADENAME: **NORZON 20X**

SHAPE: Type 29

FLAP DENSITY: Standard

ABRASIVE: Zirconia Alumina Plus

BACKING PLATE: Fiberglass

AVAILABILITY

SIZE (D x H)	GRIT	MAX. RPM	STD. PKG.	PART NO.
4 x M-10	40	15,300	5	07660703214
	60			07660703215
	80			07660703216
4-1/2 x 5/8-11	40	13,300	5	07660703211
	60			07660703212
	80			07660703213
7 x 5/8-11	40	8,600	5	07660703205
	60			07660703206
	80			07660703207
Wire Rack			2	07660704157

Wire rack (with header card) allows merchandising of 4" and 4-1/2" product three ways: hung on pegboard, mounted on an upright, or placed on a shelf/counter



Merit Mini Flap Discs



- High performance zirconia alumina abrasive provides maximum cut rate and life
- Layered flaps wear away evenly, producing a high quality and consistent finish

AVAILABILITY

TIER:	BETTER	BETTER
ABRASIVE:	Zirconia Alumina	Zirconia Alumina
FLAP:	Cotton	Cotton
BACKING MATERIAL:	Extra Heavy Duty Plastic	Extra Heavy Duty Plastic
ATTACHMENT:	TS (Type II)	TR (Type III)



SIZE (D)	GRIT	STD. PKG.	PART NO.	PART NO.
2"	36	10	08834195020	08834194550
	40		08834195021	08834194551
	60		08834195022	08834194552
	80		08834195023	08834194553
	120		08834195024	08834194554
3"	36	10	08834195035	08834194563
	40		08834195036	08834194564
	60		08834195037	08834194565
	80		08834195038	08834194566
	120		08834195039	08834194567



TS (TYPE II)

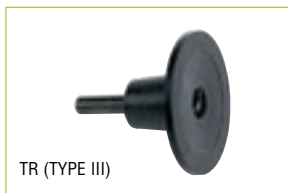

TR (TYPE III)

DESCRIPTION	STD. PKG.	MAX. RPM	PART NO.
Mini Flap Disc Back-up Pads			
2" & 3" TS (Type II) Back-up Pads	1	30,000	08834168539
2" & 3" TR (Type III) Back-up Pads	1	30,000	08834160172



NORTON
SAINT-GOBAIN
DRYice

NORTON
SAINT-GOBAIN
A275OP

NORTON
SAINT-GOBAIN
BLUEfire

PB273



CATEGORY DEFINITION

For use on random orbital and rotary sanders. The industry's highest performing and broadest selection of paper discs in PSA (pressure sensitive adhesive) disc rolls, individual discs, and hook and loop discs.

APPLICATIONS:	Stripping and preparing primed and painted surfaces for finishing, sanding of plastics, fiberglass and composites, bare wood sanding, light weld blending, preparing and finishing metal, and sanding of all gel coat and body filler compounds
SIZE RANGE:	3" – 8"
GRIT RANGE:	36 – 2500
ABRASIVE GRAIN:	Ceramic Alumina, Zirconia Alumina, Aluminum Oxide, Silicon Carbide
ATTACHMENT SYSTEMS:	PSA (pressure-sensitive adhesive), hook and loop
PAPER WEIGHTS:	Heavyweight – E and F; Lightweight – A, B and C
VACUUM HOLES:	See product availability charts

MATERIAL/APPLICATION-TO-PRODUCT RECOMMENDATION GUIDE

	BEST Highest Productivity – Lowest Total Cost		BETTER Excellent Blend of Performance & Price		GOOD Consistent Performance – Low Initial Price	
	Heavy-Medium Stock Removal	Light Stock Removal-Finishing	Heavy-Medium Stock Removal	Light Stock Removal-Finishing	Heavy-Medium Stock Removal	Light Stock Removal-Finishing
Primed, Painted Surfaces		A975	H875P	A275	H290	PB273
Fiberglass / Composites / Gel Coats		A975	H875P	A275	H290	PB273
Wood		A975	H875P	A275	H290	PB273
Metal	H920	A975	H822	A275	H290	PB273
Body Fillers / Compounds / Plastics		A975	H875P	A275	H290	PB273

APPLICATION/GRIT RECOMMENDATION GUIDE

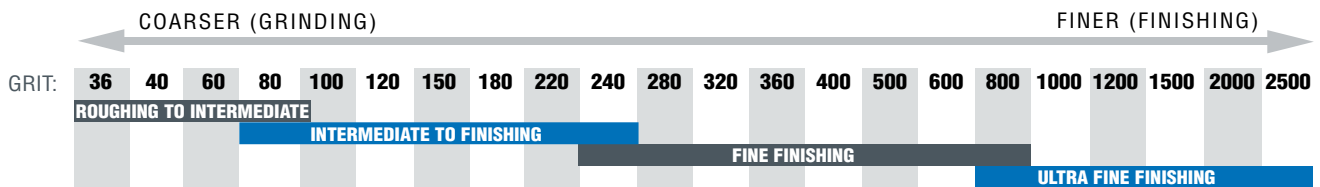

CROSS REFERENCE GUIDE



	BEST		BETTER					GOOD		
	F-Wt.	B- & C-Wt.	F-Wt.	E-Wt.	B-Wt.	B-Wt.	B-Wt.	E-Wt.	C-Wt.	B-Wt.
NORTON	Norton SG H920	Dry Ice A975	BlueFire H822	BlueFire H875P	Adalox A275	Adalox A270	Durite A475	Adalox H290	Adalox A290	Merit PB273
3M	763U, 7511	734U, 735U, 765L	–	750U, 751U, 740I, 745I	216U, 255L, 260L, 334U	210U, 268L, 360L	414N, 415N, 405N, 415U, 435U	363I	236U	214U, 316U Red. NX
Hermes	CB115	–	BW 115	–	VC154-LL	VC152	PSF-LL, SF168	VC152	HCAB-LL, HC135, VC151-LL	–
Indasa	–	–	–	–	RedLine	–	–	–	–	WhiteLine
Klingspor	–	PS36	PS20, PS21, PS22	–	PS33	–	PL35	–	PS33	PL36
Mirka	–	–	–	Royal Coarse Cut	Q-Silver, Royal, Royal Micro	Silver	CaratFlex, PolarStar	–	Bulldog Gold, Basecut	Carat (B), Basecut
SIA	–	1950	1820, 1919	1820, 1919	1940, 1950	–	1748	–	1947	–
VSM	–	–	–	KP510E, KP709	MPG	–	CP131A	–	KP911	MP10



FEATURED PRODUCTS



NORTON SG H920

BEST CHOICE FOR MORE DEMANDING STOCK REMOVAL APPLICATIONS

FEATURES

- Patented Norton SG ceramic alumina abrasive
- Strong, heavy F-wt. paper, synthetically-coated

BENEFITS

- Maximum life; fast aggressive cutting action, yet cool cutting
- Maximum durability and chip resistance, ideal for soldered and welded areas, and unpainted metal applications



EXPANDED OFFERING

NO-FIL NORTON DRYICE A975

BEST CHOICE FOR THE MOST DEMANDING SANDING APPLICATIONS

FEATURES

- Patented P-graded Norton SG ceramic alumina abrasive
- Unique fiber-reinforced, flexible B- and C-wt. latex-saturated backing
- Water-based No-Fil stearate, non-pigmented

BENEFITS

- Fastest cut rate; longest life of any paper disc
- 50-60% improvement in tear strength, longer life in all applications
- Flexible; can be used wet
- Provides maximum load resistance and extended life; no color transfer



IMPROVED

NORTON BLUEFIRE H875P

BETTER CHOICE FOR SOFT MATERIAL APPLICATIONS

FEATURES

- Next-generation zirconia alumina abrasive
- Strong, heavy, E-wt. paper
- Open coat design

BENEFITS

- Extended life over original zirconia alumina products
- Improved cut rate
- Increased durability and chip resistance, flexible
- Reduced loading; ideal for body-filler, fiberglass and composites



NO-FIL NORTON ADALOX A275

BETTER CHOICE FOR HIGH-PERFORMANCE DRY FINISHING ON ALL MATERIALS

FEATURES

- Premium P-graded, heat-treated aluminum oxide abrasive
- Unique fiber-reinforced, flexible B-wt. latex-saturated backing
- Water-based stearate, non-pigmented, No-Fil coating
- 5" and 6" individual PSA discs in fine grits have a tabbed, white translucent liner

BENEFITS

- Superior life, fast cut rate, consistent finish
- 50-60% improvement in tear strength
- Flexible; can be used wet
- Provides maximum load resistance and extended life; no color transfer to work
- The PSA adhesive is protected from air-borne contaminants
- The tab allows easier removal of the paper liner



NO-FIL NORTON DURITE A475

BETTER CHOICE FOR HARD-TO-SAND SURFACES AND WOOD APPLICATIONS

FEATURES

- P-graded, hard, silicon carbide abrasive
- Water-based stearate, non-pigmented, No-Fil coating
- Durable, fiber-reinforced, B-wt. latex paper

BENEFITS

- Easy penetration of the hardest surfaces
- Resists loading for the longest usable product life; no color transfer to work
- Provides flexibility and resistance to tearing



EXPANDED OFFERING

MERIT NO-LOAD PB273

GOOD CHOICE FOR SANDING PAINT, PRIMER, PLASTICS, FIBERGLASS, AND WHITEWOOD AT A LOW INITIAL PRICE

FEATURES

- P-graded, aluminum oxide abrasive
- Flexible latex B-wt. backing, with a full resin bond and open coat
- Water-based stearate, non-pigmented, No-Fil coating

BENEFITS

- Fast cutting action and extended life with consistent finish
- Improved resistance to delamination; no delamination to back-up pad
- Can be used moist or wet
- Provides improved load resistance
- No color transfer to work

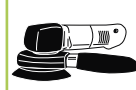

AVAILABILITY
STICK AND SAND (PSA)
DISC ROLLS
NON-VACUUM



TIER:	BEST	BETTER	BETTER	GOOD	GOOD
BRAND:	Norton	Norton	Norton	Norton	Merit
CAP CODE:	A975 NO-FIL	A275 NO-FIL	A475 NO-FIL	A290 NO-FIL	PB273 NO-LOAD
ABRASIVE:	Ceramic Alumina	Aluminum Oxide	Silicon Carbide	Aluminum Oxide	Aluminum Oxide
PAPER BACKING WEIGHT:	B- & C-Weight	B-Weight	B-Weight	C-Weight	B-Weight
OTHER:	P-Graded	P-Graded	P-Graded	P-Graded	P-Graded

SIZE	GRIT	ROLLS/ STD. PKG.	DISCS/ ROLL	PART NO.	PART NO.	PART NO.	PART NO.	PART NO.
3-1/2	80	4	100		66261136376			
	120			66261136375				
	180			66261136373				
	220			66261136372				
	320			66261136369				
	400			66261136368				
5	60	4	100		66261131464*	66254487415	66261149831	
	80			66261140502	66261131463*	66254487417	66261149830	66623362930
	100			66261140501	66261131462*	66254487418	66261149829	
	120			66261140500	66261131461*	66254487440	66261149828	66623362929
	150			66261140499	66261131460*	66254487441	66261149827	66623362928
	180			66261140498	66261131459*	66254487442	66261149826	66623362927
	220			66261142474	66261131458*	66254487443	66261149825	66623362926
	240			66261155380	66261131457*		66261149824	66623362925
	280			66261155379	66261131456*	66254487444	66261149823	
	320			66261155378	66261131454*	66261065293	66261149822	66623362924
	400			66261155377	66261131453*		66261149821	66623362923
	500			66254480231	66261131452*	66254421217		66623362922
	600			66623305608	66261131451*	66254401221		66623362921
	800			66254480230				
6	60	4	100		66261131481*	66254487446	66261149847	
	80			66261140512	66261131480*	66261149842	66623362940	
	100			66261140511	66261131479*	66261149841	69957352447	
	120			66261140510	66261131478*	66254487447	66261149840	66623362939
	150			66261140509	66261131477*	66261149839	66261149838	66623362938
	180			66261140508	66261131476*	66254487448	66261149837	66623362937
	220			66261148340	66261131475*	66254487449	66261149836	66623362936
	240			66261155376	66261131474*		66261149835	66623362935
	280			66261155375	66261131473*	66254487450	66261149834	66623362934
	320			66261155374	66261141198*			
	360				66261131471*		66261149833	66623362933
	400			66261155373	66261131470*			
	500			63642506198*	66261131469*			
	600			63642506199*	66261131468*			66623362932
800	63642506200*				66623362931			
8	80	4	100		66261131617			
	120			66261131615				
	150			66261131614				
	180			66261131613				
	220			66261131612				
	320			66261131609				

* PACKAGING STANDARDS A975, A275 = 6/100



PSA Disc Roll Dispenser

- Norton disc roll dispensers feature heavy-duty construction and a rubberized finish to protect your product, as well as the finish on your workpiece
- These versatile dispensers are designed to accommodate any 5" or 6" disc roll or sheet roll
- They can be attached to a wall or stacked for multi-grit or multi-diameter operations
- Discs are individually dispensed and removed from the roll by a cutter bar

DESCRIPTION	STD. PKG.	PART NO
PSA Disc Roll Dispenser		
Single Disc Roll Dispenser	1	63642542772
Double Disc Roll Dispenser (shown)	1	63642502981

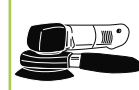

AVAILABILITY
STICK AND SAND (PSA)
DISC ROLLS
NON-VACUUM



TIER:

BRAND:

CAP CODE:

ABRASIVE:

PAPER BACKING WEIGHT:

SIZE	GRIT	ROLLS/STD. PKG.	DISCS/ROLL	PART NO.	PART NO.	PART NO.
5	60	4	100	66261149873	66261137310	
	80			66261149872	66261137309	66261124977
	100			66261149871	66261137308	66261125597
	120			66261149870	66261137307	
	150				66261137306	
6	60	4	100	66261149876	66261137323	
	80			66261149874	66261137322	66261125573
	120					
8	100	4	50	66261149879		
	120				66261137333	

AVAILABILITY
STICK AND SAND (PSA)
DISC ROLLS – VACUUM



TIER:

BRAND:

CAP CODE:

ABRASIVE:

PAPER BACKING WEIGHT:

OTHER:



GOOD





Norton

A290 NO-FIL

Aluminum Oxide

C-Weight

P-Graded

SIZE	GRIT	ROLLS/STD. PKG.	DISCS/ROLL	PART NO.	ROLLS/STD. PKG.	DISCS/ROLL	PART NO.
							
5	60	6	100	66261131498	4	100	66261130266
	80			66261131497			66261130265
	100			66261131496			66261130264
	120			66261131495			66261130263
	150			66261131494			66261130262
	180			66261131493			66261130261
	220			66261131492			66261130260
	240			66261131490			66261130259
	320			66261131488			66261130258
	400			66261131487			
	500						
							
6	80	6	100	66261131515	4	100	66261130276
	100			66261131514			66261130275
	120			66261131513			66261130274
	150			66261131512			66261130273
	180			66261131511			66261130272
	220			66261131510			66261130271
	240			66261131509			
	280			66261131508			
	320			66261131507			
	400			66261131505			66261130268
	600			66261131503			

Refer to the end of this section for back-up pads and accessories.

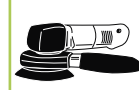

AVAILABILITY
HOOK AND LOOP
NON-VACUUM



TIER:	BEST	BEST	BEST	BETTER	BETTER	BETTER	GOOD	GOOD
BRAND:	Norton	Norton	Norton	Norton	Norton	Norton	Merit	Norton
CAP CODE:	H920	A975 NO-FIL	Q260	H875P	A275 NO-FIL	A475 NO-FIL	PB273 NO-LOAD	A290 NO-FIL
ABRASIVE:	Ceramic Alumina	Ceramic Alumina	Aluminum Oxide	Zirconia Alumina	Aluminum Oxide	Silicon Carbide	Aluminum Oxide	Aluminum Oxide
PAPER BACKING WEIGHT:	F-Weight	B- & C-Weight	Film	E-Weight	B-Weight	B-Weight	B-Weight	C-Weight
OTHER:		P-Graded	P-Graded		P-Graded	P-Graded	P-Graded	P-Graded

SIZE	GRIT	MIN./ STD PKG.	PART NO.	PART NO.	PART NO.	PART NO.	PART NO.	PART NO.	PART NO.	PART NO.
3	80	50/200					66261131532			
	100						66261144926			
	120						66261128688			
	150						66261140385			
	180						66261131528			
	220						66261131527			
	240						66261131526			
	320						66261131524			
	400						66261136995			
	500						66261131521			
	600						66261136996			
	800						66261131519			
	1000					63642506068		66261135900		
1200				63642506069						
1500				63642506070		66261147434				
5	40	25/100				66261125684				
	60	100/400	66261149864*							66261130224
	80		66261149865*	66261140522‡		66261125444•	66261131549		66623362950	66261149907
	100		66261149866*	66261140521‡			66261131548		66623365788	66261149906
	120		66261149867*	66261140520‡			66261131547		66623362949	66261149905
	150			66261140519‡			66261131546		66623362948	66261149904
	180			66261140518‡			66261131545		66623362947	66261149903
	220			66261149541‡			66261131544		66623362946	66261149902
	240			66261149540‡			66261131543		66623362945	
	280						66261131542			
	320				66261149538‡		66261131541		66623362944	66261149900
	400				66261149537‡		66261131539	66261052270	66623362943	66261149899
	500				66254480233‡		66261131538			
	600				66663305616‡		66261131537	66254421221	66623362942	
	800				66254480232‡		66261131536	66261052267	66623362941	
	1000						66261131535	66261052254		
	1200						66261131534			
1500						66261131533				
6	36	25/100				66261123590				
	40					66261123589				
	80	100/400				66261123588•				
	100			66261140532‡		66261131566		66623362960	66261149916	
	120			66261140531‡		66261131565		66623365789	66261149915	
	150			66261140530‡		66261131564		66623362959	66261149914	
	180			66261140529‡		66261131563		66623362958	66261149913	
	220			66261140528‡		66261131562		66623362957	66261149912	
	240			66261149546‡		66261131561		66623362956	66261149911	
	280					66261131560		66623362955		
	320				66261149543‡		66261131559			66261149910
	400				66261149542‡		66261131558	66261052269	66623362954	66261149909
	500				63642506202‡		66261131556		66623362953	66261149908
	600				63642506203‡		66261131555			
	800				63642506204‡		66261131554		66623362952	
1000				63642506375‡	63642506041‡	66261131553	66261052268	66623362951		
1200				63642506376‡	63642506042‡	66261131552	66261052255			
1500			63642506377‡	63642506043‡	66261131551					
8	36	25/100				66261123593				
	40					66261123592				
	60	50/250								
	80					66261123591•				
	100	50/250								
	120	100/400								
180						66261131662				
						66261131661				

PACKAGING STANDARDS: MIN. / STD. PKG.

* H920 = 50/250

‡ A975, Q260, A290 = 50/200

• H875P = 25/100



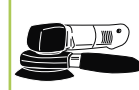



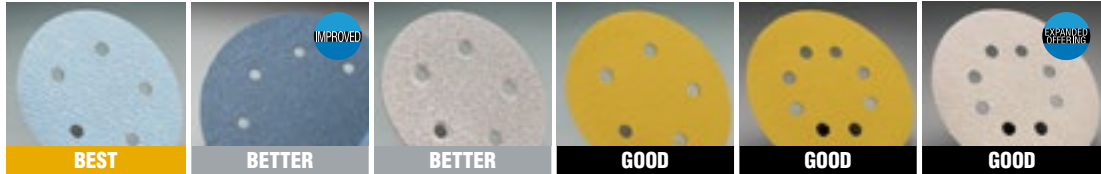

Refer to the end of this section for back-up pads and accessories.



AVAILABILITY
HOOK AND LOOP
VACUUM

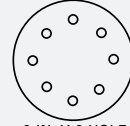

TIER:	BEST	BETTER	BETTER	GOOD	GOOD	GOOD
BRAND:	Norton	Norton	Norton	Norton	Norton	Merit
CAP CODE:	A975 NO-FIL	H875P	A275 NO-FIL	A290 NO-FIL	A290 NO-FIL	PB273 NO-LOAD
ABRASIVE:	Ceramic Alumina	Zirconia Alumina	Aluminum Oxide	Aluminum Oxide	Aluminum Oxide	Aluminum Oxide
PAPER BACKING WEIGHT:	B- & C-Weight	E-Weight	B-Weight	C-Weight	C-Weight	B-Weight
OTHER:	P-Graded		P-Graded	P-Graded	P-Graded	P-Graded

SIZE	GRIT	MIN./ STD PKG.	PART NO.	PART NO.	PART NO.	PART NO.	PART NO.	PART NO.
5	60	100/400	 5 IN. X 5 HOLE DIE #3328		 5 IN. X 5 HOLE DIE #3328	 5 IN. X 5 HOLE DIE #3328	 5 IN. X 8 HOLE DIE #3392	 5 IN. X 8 HOLE DIE #3392
	80		66261140517‡		66261131583	66261130236‡	66261130245‡	66623366071
	100				66261131582	66261130235‡	66261130244‡	
	120		66261140515‡		66261131581	66261130234‡	66261130243‡	66623369778
	150				66261131580	66261130233‡	66261130242‡	66623366073
	180				66261131579	66261130232‡	66261130241‡	66623366074
	220				66261131578	66261130231‡	66261130240‡	66623366075
	240				66261131577	66261130230‡	66261130239‡	
	280							
	320				66261131575	66261130227‡	66261130238‡	66623366077
	400				66261131573	66261130226‡		
600				66261131571				
6	80	100/400	 6 IN. X 6 HOLE DIE #3371		 6 IN. X 6 HOLE DIE #3371	 6 IN. X 6 HOLE DIE #3371		 6 IN. X 6 HOLE DIE #3371
	100		66261140527‡		66261131600	66261130255‡		66623367394
	120				66261131599			
	150				66261131598	66261130253‡		66623367397
	180				66261131597			66623367398
	220				66261131596	66261130251‡		66623367399
	280				66261131595	66261130250‡		
	320		66261149553‡		66261131593			66623367400
	400				66261131592			66623367401
	600				66261131590			
	800				66261131588			
1000				66261131587				
1200				66261131586				
1500				66261131585				
8	36	25/100		 8 IN. X 8 HOLE DIE #3370				
	80				66261123598			
					66261123596			

PACKAGING STANDARDS: ‡ A975, A975 VACUUM, A290 VACUUM = 50/200

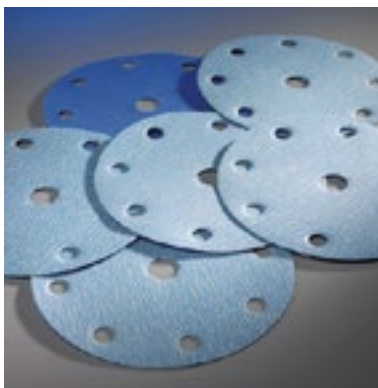

For Fein/Festo Sanders

High-performance abrasives for high performance sanders. Now available: No-Fil Norton Drylce A975 discs with center vacuum hole for Fein and Festo random orbital sanders.

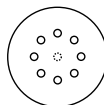

6 IN. X 9 HOLE
DIE #3408-2

TIER:	BEST
BRAND:	Norton
CAP CODE:	A975 NO-FIL
ABRASIVE:	Ceramic Alumina
PAPER BACKING WEIGHT:	B- & C-Weight
OTHER:	P-Graded

SIZE	GRIT	STD. PKG.	PART NO.
6	80	50/200	07660705489
	100		07660705488
	120		07660705487
	150		07660705486
	220		07660705484

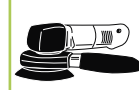

AVAILABILITY
INDIVIDUAL
STICK AND SAND
(PSA) DISCS

TIER:

BRAND:

CAP CODE:

ABRASIVE:

PAPER BACKING WEIGHT:

FASTENING:

OTHER:

BETTER	BETTER	BETTER	GOOD	GOOD
Norton	Norton	Norton	Norton	Merit
H875P	H875P	A275 NO-FIL	H290	PB273 NO-LOAD
Zirconia Alumina	Zirconia Alumina	Aluminum Oxide	Aluminum Oxide	Aluminum Oxide
E-Weight	E-Weight	B-Weight	F-Weight	B-Weight
PSA	PSA Vacuum	PSA Tabbed	PSA	PSA Tabbed
		P-Graded	P-Graded	P-Graded

SIZE	GRIT	MIN./ STD PKG.	PART NO.	PART NO.	PART NO.	PART NO.	PART NO.
				 5" X 5 HOLE DIE #3328			
5	36 40 80 100 120 150 180 220 240 320 400 600 800 1000 1200	50/200 100/400	66261125436 66261125307 66261125244	66261124919			69957348198‡ 69957348200 69957348201 69957348202 69957348203 69957348204 69957348205 69957348206 69957348207 69957348223 69957348224
				 6" X 6 HOLE DIE #3371			
6	36 40 80 1000 1200 1500	50/200 100/400	66261123575 66261123574 66261123573	66261123580	66261131467 66261131466 66261131465	66261130834‡ 66261130833‡ 66261130832‡	
				 8" X 8 HOLE DIE #3370			
8	36 40 80	25/100	66261123578 66261123577 66261123576	66261123584 66261123582		66261130827• 66261130826•	

PACKAGING STANDARDS:
MIN. / STD. PKG.
• H290 = 50/200
‡ H290 AND PB273 = 100/400

Refer to the end of this section for back-up pads and accessories.

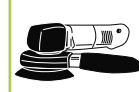

FEATURED PRODUCTS



MULTI-AIR HOOK AND LOOP VACUUM

LESS DUST; MORE PRODUCTIVITY

FEATURES

- Revolutionary design for maximum vacuum assist
- Cutting surface of disc remains clean
- Highly-engineered back-up pad
- Unique SoftTouch discs on durable foam in fine grits
- A975: Expanded offering of stock 5" 400 - 800 grit and 6" 120 - 1000 grit discs

BENEFITS

- 30% increase in dust extraction; clogging is virtually eliminated
- Cleaner working environment; less dust and contamination
- 35% increase in productivity versus traditional vacuum systems
- No clogging; consistent cut throughout the life of the disc
- Revolutionary style for maximum dust extraction
- Sand over contours without cutting through
- Color-coded by grit size for easy identification
- Ideal for polishing and finishing jobs

AVAILABILITY
HOOK AND LOOP
VACUUM



TIER:	BEST	BEST	BETTER
BRAND:	Norton	Norton	Norton
CAP CODE:	A975 NO-FIL	BLUEFIRE H835	A275 NO-FIL SOFTTOUCH
ABRASIVE:	Ceramic Alumina	Zirconia Alumina	Aluminum Oxide
PAPER BACKING WEIGHT:	B- & C-Weight	E-Weight	B-Weight
OTHER:	P-Graded		P-Graded

SIZE	GRIT	MIN./STD PKG.	PART NO.	PART NO.	PART NO.	
5 x 11/16	80	100/400	63642563535			
	120		63642563536			
	150		63642563537			
	180		63642563538			
	220		63642563539			
	320		63642563542			
	400		63642563543			
	500		66623327202			
	600		66623327203			
	800		66623327204			
6 x 11/16	80	50/200	63642506243	66261181412		
	120	100/400	63642506244 *			
	150		63642506245 *			
	180		63642506246 *			
	220		63642506247 *			
	240		63642506248 *			
	320		63642506250 *			
	400		63642506251 *			
	500		63642506252 *			
	600		63642506253 *			
	800		63642506254 *			
	800		20/80			63642560577
	1000				63642506378	63642560578
	1500					63642560579

*A975 6" DISCS: MIN./STD. PKG. - 50/200



Multi-Air Foam Interface Pads

- Allow sanding of contours and improve surface finish.
- Use with fine grit hook and loop Multi-Air sanding discs.
- Use with Multi-Air back-up pads.
- Not for use with Multi-Air SoftTouch discs.

DESCRIPTION	STD. PKG.	PART NO.
Multi-Air Interface Pads		
5" Pad	16	63642585864
6" Pad	12	07660719359
8" Pad	10	07660782019



Multi-Air Hook and Loop Back-up Pads with Vacuum Holes

- Multi-Air back-up pads are engineered to work as a system with our Multi-Air discs to enhance the performance of the discs by aligning with the discs' holes maximizing dust extraction and life of the discs.
- These pads are recommended for all Multi-Air applications.
- Pads have longer hooks for maximum hold.

DESCRIPTION	STD. PKG.	PART NO.
Multi-Air Back-Up Pads with Vacuum Holes		
5" (125mm) with 5/16"-24 Shank, Urethane Pad	1	66623376000
6" (150mm) with 5/16"-24 Shank, Urethane Pad	1	63642506160
8" (203mm) 5-Bolt for National Detroit	1	07660782017



Low-Profile Pads for Dual Action / Random Orbital Sanders

- Soft density low-profile pads utilize 1/2" thick foam for fine finish sanding and offer moderate conformability.
- Medium low-profile pads have 1/2" thick urethane foam for intermediate and finish sanding.
- Firm density low-profile pads utilize 1/4" thick urethane foam for flash and seam removal.
- Available with PSA or hook and loop faces. Both designs are shock resistant and have a fiberglass backing plate with a riveted 5/16"-24 threaded shank for added strength and increased heat resistance.
- Available with standard hole patterns for vacuum-assist sanding.

DESCRIPTION	MAX. RPM	STD. PKG.	PART NO.
Low Profile Pads for DA/Random orbital Sanders			
3" Foam Polishing Pad		10	63642504295
3" Hook & Loop Soft Low-Profile	12,000	10*	63642506128
3" x 7/8" Hook & Loop Pad		10	63642541947
3-1/4" Hook & Loop Buffing Pad		5*	66261085302
5" PSA Soft Low-Profile	12,000	5*	63642506126
5" PSA Medium Low-Profile	15,000	5*	63642506131
5" PSA Medium Low-Profile with 5 vacuum holes	15,000	5*	63642506132
5" Hook & Loop Soft Low-Profile	12,000	5*	63642506129
5" Hook & Loop Medium Low-Profile	15,000	5*	63642506135
5" Hook & Loop Medium Low-Profile with 5 vacuum holes	15,000	5*	63642506136
6" PSA Soft Low-Profile	12,000	5*	63642506127
6" PSA Medium Low-Profile	15,000	5*	63642506133
6" PSA Medium Low-Profile with 6 vacuum holes	15,000	5*	63642506134
6" Hook & Loop Soft Low-Profile	12,000	5*	63642506130
6" Hook & Loop Medium Low-Profile	15,000	5*	63642506137
6" Hook & Loop Medium Low-Profile with 6 vacuum holes	15,000	5*	63642506138
8" Hook & Loop Medium Low-Profile with 8 vacuum holes, 5 screw	1,500	5*	63642543712
8" Hook & Loop Medium Low-Profile with 8 vacuum holes, 6 screw	1,500	5*	63642543714

* PACKED IN INDIVIDUAL CLAMSHELL



Tapered Pads for Dual Action / Random Orbital Sanders

- Designed with medium density polyurethane foam and a tapered edge for conformability, these pads are firm enough for flat surfaces, yet soft enough for severe curves and contours.
- Available with either PSA (vinyl) or hook and loop faces in vacuum or non-vacuum.
- The 5" and 6" pads are shock resistant and have a fiberglass backing plate with a riveted 5/16"-24 threaded shank for use on random orbital or dual action sanders.
- The 8" pads have a 5/8"-11 threaded female hub.

DESCRIPTION	MAX. RPM	STD. PKG.	PART NO.
Tapered Pads for DA/Random Orbital Sanders			
5" PSA Medium Tapered	15,000	5*	63642506139
5" PSA Medium Tapered with 5 vacuum holes	15,000	5*	63642506140
5" Hook & Loop Medium Tapered	15,000	5*	63642506143
5" Hook & Loop Medium Tapered with 5 vacuum holes	15,000	5*	63642506144
6" PSA Medium Tapered	15,000	5*	63642506141
6" PSA Medium Tapered with 6 vacuum holes	15,000	5*	63642506142
6" Hook & Loop Medium Tapered	15,000	5*	63642506145
6" Hook & Loop Medium Tapered with 6 vacuum holes	15,000	5*	63642506146
8" PSA Medium Tapered	6,000	5*	63642543112
8" Hook & Loop Medium Tapered	3,200	5*	63642543704

* PACKED IN INDIVIDUAL CLAMSHELL



Hook & Loop Foam Interface Pads

- Designed for use with our fine grit hook and loop sanding discs.
- Improve both surface finish and cut rate.
- Use with hook and loop back-up pads.

DESCRIPTION	STD. PKG.	PART NO.
Foam Hook & Loop Interface Pads		
3" Diameter, 1/2" Thick Interface	10	63642505457
6" Diameter, 1/2" Thick Interface	5	63642542089
5" Diameter, 3/4" Thick Interface	2	63642502161
6" Diameter, 3/4" Thick Interface	2	63642502162



Half Moon Hand Pad

- The unique half moon pad uses a standard 5" hook and loop disc folded in half, which adheres to the hooks on the pad face.
- The straight edge of the pad allows the operator to sand corners, contours, narrow crevices and minute imperfections without over-sanding.

DESCRIPTION	STD. PKG.	PART NO.
Half Moon Hand Pad		
5" Hook and Loop	10	63642502768



Polishing Adapter Pad

- Converts your standard hook and loop pad into a soft polishing pad.
- The foam adapter is 3/8" thick and is excellent for fine grits where minimal removal is required.
- It is ideal for either flat or contour surfaces.

DESCRIPTION	MAX. RPM	STD. PKG.	PART NO.
Polishing Adapter Pad			
5" Hook and Loop Adapter Pad	3,786	10	63642503121



Ergonomic Hand Sanders

- The ergonomic palm sander is uniquely designed to be user-friendly, with finger indentations for the operator.
- It quickly converts standard 5" and 6" hook and loop discs into hand sanders for finishing flat surfaces.

DESCRIPTION	STD. PKG.	PART NO.
Ergonomic Hand Sander		
5" Hook and Loop	5	63642503147
6" Hook and Loop	5	63642503726



Disc Hand Pads

- Hand pads eliminate finger sanding.
- The 1" thick pad is composed of two layers, neoprene and polyester foam, for excellent conformability and softness, resulting in fine finishes.
- The ultra-thin 3/16" thick pad is composed of a single layer of neoprene foam and is designed for maximum flexibility – producing excellent finishes.
- Each pad has an elastic hand strap to hold it firmly in place.
- Available with either PSA (vinyl) faces or hook and loop face.

DESCRIPTION	STD. PKG.	PART NO.
Disc Hand Pads		
5" x 3/16" Thick Soft Foam PSA	10	63642503111
5" x 1" Thick Soft Foam PSA	10	63642502842
5" x 1" Thick Soft Foam Hook and Loop	10	63642503117



Panel and Adhesive Cleaner

- Removes adhesives, tar, grease, wax, body sealers, undercoating sprays, and silicone from most surfaces.
- Aggressive cleaner is safe to use on most paint applications.
- Packaged with squirt dispenser.
- Use as directed.

DESCRIPTION	STD. PKG.	PART NO.
Panel and Adhesive Cleaner		
Quart Can	12	07660782780



CATEGORY DEFINITION

Norton PSA and Merit ShurStik PSA (pressure sensitive adhesive) individual cloth discs and disc rolls are used on three different types of machines and the application changes depending on which one they are used on.

- APPLICATIONS:** Pneumatic Die Grinders and Electric Random Orbital Sanders – for use on contours or flat surfaces for light- to medium-pressure grinding, blending, leveling, and finishing applications
Stationary Disc Sanders – used in woodworking and metalworking for stock removal, sanding/grinding flat surfaces, dimensioning and finishing
- SIZE RANGE:** 1/2" – 24" diameter
- GRIT RANGE:** 24 – 320
- ABRASIVE GRAIN:** Ceramic Alumina, Zirconia Alumina, Aluminum Oxide
- BACK-UP PADS:** Rubber, with hardness variations for different applications, for portable machines. Steel for stationary disc sanders



Small Diameter Cloth Discs for Pneumatic Die Grinders

AVAILABILITY



TIER:	GOOD
BRAND:	Merit
TRADENAME:	SHURSTIK
ABRASIVE:	Aluminum Oxide
ATTACHMENT:	PSA

GRIT	1/2"	3/4"	1"	1-1/2"	2"	3"	4"
24	-	-				08834171173	08834171188
36	08834171100	08834171114	08834171129	08834171144	08834171159	08834171174	08834171189
40	08834171101	08834171115	08834171130	08834171145	08834171160	08834171175	08834171190
50	08834171102	08834171116	08834171131	08834171146	08834171161	08834171176	08834171191
60	08834171103	08834171117	08834171132	08834171147	08834171162	08834171177	08834171192
80	08834171104	08834171118	08834171133	08834171148	08834171163	08834171178	08834171193
100	08834171105	08834171119	08834171134	08834171149	08834171164	08834171179	08834171194
120	08834171106	08834171120	08834171135	08834171150	08834171165	08834171180	08834171195
150	08834171107	08834171121	08834171136	08834171151	08834171166	08834171181	08834171196
180	08834171108	08834171122	08834171137	08834171152	08834171167	08834171182	08834171197
240	08834171109	08834171123	08834171138	08834171153	08834171168	08834171183	08834171198
320	08834171110	08834171124	08834171139	08834171154	08834171169	08834171184	08834171199
QTY./ BOX	100	100	100	100	100	100	100
BACK-UP PADS	1/4" Shank 15,000 RPM 08834174096	1/4" Shank 15,000 RPM 08834174097	1/4" Shank 15,000 RPM 08834174098	1/4" Shank 15,000 RPM 08834174099	1/4" Shank 12,000 RPM 08834174100	1/4" Shank 10,000 RPM 08834174101	1/4" Shank 6,000 RPM 08834174102



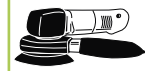

Cloth PSA Discs for Random Orbital Sanders

FEATURED PRODUCTS



NORTON SG R938

BEST CHOICE FOR FLASH AND SEAM REMOVAL ON MOLDED PARTS AND A BROAD RANGE OF NONFERROUS METALWORKING AND WOODWORKING APPLICATIONS

FEATURES

- Patented, P-graded, Norton SG (ceramic alumina) grain
- All resin bond
- Strong, semi-flexible X-weight cotton cloth backing
- DL (dustless) anti-static
- Discs are tabbed

BENEFITS

- Maximum life; rapid, cool cutting; consistent finishes
- Provides excellent grain retention and load resistance
- Durable; resistant to heat
- Cleaner workpiece and equipment
- Easy application and removal

AVAILABILITY

TIER:
BRAND:
TRADENAME:
ABRASIVE:
ATTACHMENT
OTHER:



BEST

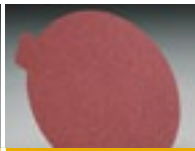

BEST



GOOD



GOOD

Norton	Norton	Norton
BLAZE R980P	SG R938	METALITE R228
Ceramic Alumina	Ceramic Alumina	Aluminum Oxide
PSA Discs	PSA Tabbed Discs	PSA Discs
	P-Graded	

Norton
METALITE R228
Aluminum Oxide
PSA Discs Roll

SIZE (D)	GRIT	MIN./ STD. PKG.	PART NO.	PART NO.	PART NO.	STD. PKG/ DISCS/ROLL	PART NO.	
5"	36	50/250	66254461506		66261136589	4/100	66261133252	
	40		66254461507		66261136588			
	50		66254461508		66261136587			
	60		66254461509		66261136586			
	80		66254461510		66261136585			
	100				66261139833			66261136584
	120		66254461512		66261139834			66261136583
	150							66261136582
180			66261136581					
6"	60	50/250			66261136596			
	80				66261136595			
	100				66261136594			
	120				66261136593			
	180				66261136592			
8"	36	50/250			66261136350			
	40				66261136351			
	50				66261136352			
	60				66261136376			
	80				66261136354			
	120				66261136355			

Back-up Pads for Cloth PSA Discs

DESCRIPTION	MAX. RPM	STD. PKG.	PART NO.
Back-up Pads for Cloth PSA Discs			
5" Diameter – Low Profile – Soft	12,000	5	63642506126
5" Diameter – Low Profile – Medium	12,000	5	63642506131
5" Diameter – Tapered – Medium	12,000	5	63642506139
6" Diameter – Low Profile – Soft	10,000	5	63642506127
6" Diameter – Low Profile – Med	10,000	5	63642506133
6" Diameter – Tapered – Medium	10,000	5	63642506141
8" Diameter – Tapered – Medium	6,000	5	63642543112



Large Diameter Cloth PSA Discs

Used on stationary disc machines for dimensioning and finishing metal workpieces and woodworking. Pressure sensitive adhesive offers fast, convenient mounting. Made without center holes for full-face usage.



NORTON BLAZE R980P

BEST CHOICE FOR ALL HARD-TO-GRIND HIGH ALLOY STEELS

FEATURES

- Norton SG ceramic alumina abrasive
- Improved resin bond
- Self-lubricating supersize treatment
- Strong Y-weight. polyester backing

BENEFITS

- Coolest cut; significantly faster cut rate
- Better grain adhesion, edge-fray resistance
- Cool cut on harder-to-grind materials
- Long life and consistent cut

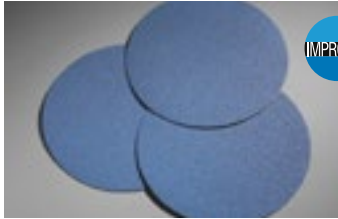

NORTON BLUEFIRE R821P

BETTER CHOICE FOR GRINDING AND DEBURRING STAINLESS STEEL

FEATURES

- Self-sharpening, zirconia alumina abrasive
- Heavy Y-weight backing

BENEFITS

- Cooler cut, extended life over aluminum oxide discs
- Durable; reduced edge wear

AVAILABILITY

TIER:
TRADENAME:
ABRASIVE:
ATTACHMENT:

		BETTER				
		NORTON BLAZE R980P				
		Ceramic Alumina				
		PSA				
WIDTH		10	12	16	18	20
36			66254416171			66254416165
40			66254416172			66254416166
50			66254416173			66254416167
60			66254416174			66254416168
80			66254416175			66254416169
120			66254416176			66254416170
MIN./STD. PKG.			25/50			25/50

AVAILABILITY

TIER:
TRADENAME:
ABRASIVE:
ATTACHMENT:

		BETTER				
		NORTON BLUEFIRE R821P				
		Zirconia Alumina				
		PSA				
WIDTH		10	12	16	18	20
24			66261138318			
36			66261138319		66261138337	66261138343
40	66261138314		66261138320			66261138344
50			66261138321	66261138333		
60	66261138316		66261138322	66261138334		66261138346
80	66261138317		66261138323	66261109128		
MIN./STD. PKG.		25/50	25/50	25/50	25/50	25/50

AVAILABILITY

TIER:
TRADENAME:
ABRASIVE:
ATTACHMENT:

		GOOD						
		NORTON METALITE R228						
		Aluminum Oxide						
		PSA						
WIDTH		10	12	15	16	18	20	24
36		66261136606	66261136635	66261136666	66261136700	66261136720	66261136710	66261136718
40		66261136604	66261136630	66261136665	66261136685		66261136709	66261136717
50		66261136607	66261136625	66261136714	66261136684		66261136711	66261136725
60		66261136602	66261136620	66261136663	66261136683	66261136696	66261136712	66261136726
80		66261136601	66261136615	66261136662	66261136701	66261136723	66261136706	66261136727
100		66261136600	66261136614					
120			66261136613					
MIN./STD. PKG.		25/50	25/50	25/50	25/50	25/50	25/50	10/10

QUICK-CHANGE DISCS



NORTON
SAINT-GOBAIN
BLAZE

NORTON
SAINT-GOBAIN
BLUEfire

NORTON
SAINT-GOBAIN
NEON

MERIT



CATEGORY DEFINITION

Tool-free, twist-on and -off fastening systems make fast work of disc changes to maximize productivity by minimizing downtime.

- APPLICATIONS:** Mini flap, fiber, and trimmable hard plastic discs: welding grinding and blending; heavy metal removal; light deburring and finishing
Cloth discs: light- to medium-pressure grinding; blending, leveling and finishing applications; for use on contours or flat surfaces
- SIZE RANGE:** 9/16" – 4" diameter
- GRIT RANGE:** 24 – 320
- ABRASIVE GRAIN:** Ceramic Alumina, Zirconia Alumina, Aluminum Oxide, Silicon Carbide
- BACKING:** Fiber or cloth
- CLOTH FLEX:** 3-ply (more aggressive), 2-ply (standard), or fx (more flexible) lamination
- ATTACHMENT:** Type TS (II), Type TR (III), and Type TP (I)
- BACK-UP PADS:** Rubber with hardness variations for different applications

COATED ABRASIVE QUICK-CHANGE DISC AVAILABILITY



Fiber

- The most heavy-duty discs with resin over resin construction on heavy-duty vulcanized fiber backing. Premium grain for applications from heavy stock removal to surface blending



NorKut

- Unique polymer backing resists cracking and breakage and can be cut down up to the 1" core. Use the cores to grind "pinch" welds and other hard-to-reach areas.



Mini Flap

- Layered flaps wear away evenly, producing an aggressive cutting action while also providing blending capabilities



Cloth 3-Ply

- These heavy-duty, 3-ply polyester laminate construction discs are the most aggressive and durable cloth discs on the market



Cloth 2-Ply

- Our standard 2-ply laminate construction creates an aggressive and durable cloth disc for flat surfaces



Cloth Flexible (fx)

- Offer a flexible, 2-ply cotton laminate construction for added conformability on contoured surfaces or any application where added flexibility is needed

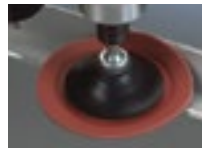

Cloth FlexEdge

- Manufactured with an abrasive cloth where the outer 3/8" is more flexible than the rest of the disc; designed to avoid gouging on contoured surfaces or soft materials

QUICK-CHANGE ATTACHMENT SYSTEMS AND CROSS REFERENCE GUIDE

Type TS (Type II)

- Features a turn-on/turn-off style fastener
- Fastener is made of metal
- Equivalent to Standard Abrasives' SocAtt® locking system



Type TR (Type III)

- Features a roll-on/roll-off style fastener
- Fastener is made of plastic
- Equivalent to 3M™ Roloc™ fastening system

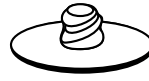

Type TP (Type I)

- Snap-on/snap-off system which enables you to change discs quickly and safely, reducing downtime and operating expenses
- Fastener is made of nylon



MERIT

Type II

Type III

Type I

NORTON

TS

TR

TP

3M	Roloc TS/TSM	Roloc TR	Roloc TP
Standard	TS (SocAtt)	TR (Lockit)	TP (ClickOn)
Superior	Type S	Type R	-
Arc	Type S	Type R	Type P
Pferd	Type CD	Type CDR	-
Sait	SAIT-LOK	SAIT-LOK-R	-
Camel	Turn On	Roll On	-
Klingspor	QMC	QRC	-
Garryson	Type S	Type R	-



MATERIAL/APPLICATION-TO-PRODUCT RECOMMENDATION GUIDE

	BEST Highest Productivity – Lowest Total Cost	BETTER Excellent Blend of Performance & Price	GOOD Consistent Performance – Low Initial Price
Stainless Steel / Titanium / Super Alloys	Norton Blaze R980P	Merit Zirc Plus	Norton Neon
Mild Carbon Steel / Welds	Merit Ceramic Plus	Norton BlueFire R884P	Merit ALO
Ferrous Metals / Cast Iron	Merit Ceramic Plus	Norton BlueFire R884P	Merit ALO
Brass / Bronze / Aluminum	–	Norton BlueFire R884P	Merit ALO
Paint / Glue / Adhesive	–	–	Merit ALO
Concrete / Stone / Fiberglass	–	–	Merit Silicon Carbide

APPLICATION/GRIT RECOMMENDATION GUIDE

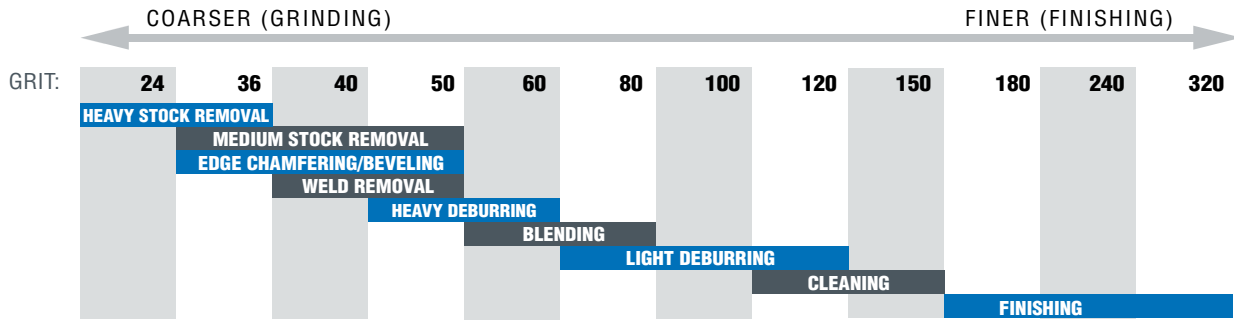

CROSS REFERENCE GUIDE



	BEST		BETTER				GOOD		
	Ceramic Alumina Full Ratio	Ceramic Alumina Full Ratio	Zirconia Alumina	Zirconia Alumina	Zirconia Alumina	Zirconia Alumina	Aluminum Oxide	Aluminum Oxide	Silicon Carbide
Abrasive	Fiber	Cloth	Fiber	Flap	Cloth	Cloth	Cloth	Cloth	Cloth
MERIT	Ceramic Plus	Ceramic Plus	Zirconia	Zirc	Zirc Plus	Zirc	ALO Plus	ALO	Silicon Carbide
NORTON	Blaze F980	Blaze R980P	–	–	–	BlueFire R884P	Neon R766	Metalite R228	–
3M	983C, 988C	963G, 977F, 785C, 777F	501C	–	–	–	–	361F	461F
Standard	–	Ceramic Pro, Ceramic	–	–	Zirconia Pro	Zirconia	A/O Extra, A/O Pro	A/O	Silicon Carbide
Superior	–	Ceramic G.A.	Zirc	–	Zirc w/ Grinding Aid	Premium Zirc	A/O w/ Grinding Aid	Premium A/O, Rigid Kut A/O	–
Arc	–	–	–	–	Zirconia/ Y Plus	Zirconia/ Y Standard	A/O/X Plus Coolant	A/O/Y Premium	–
Pferd	Ceramic Oxide CO	Ceramic Oxide CO	–	Zirconia Alumina Z	–	ZA Z	Aluminum Oxide A-Plus, Aluminum Oxide A-INOX-FORTE	Aluminum Oxide A, A/O A-FORTE	Silicon Carbide SiC
Sait	–	–	–	–	3Z, Z-H	Z	3A	2A-H, 2A	–
Camel	–	–	–	–	Zirconia AO w/ Grinding Aid	Zirconia AO	–	Aluminum Oxide	–
Klingspor	–	Ceramic	–	–	Alumina Zirconia-Lubricated	Alumina Zirconia	–	Aluminum Oxide	–
Garryson	–	Ceramic	–	–	Zirconia AO w/ Grinding Aid	–	–	Aluminum Oxide	–



Norton Blaze F980 Ceramic Fiber Discs

- Norton SG ceramic grain with self-lubricating, supersize treatment provides coolest cut; significantly faster cut rates
- Heaviest fiber backing, greater durability, longest life, and edge-fray resistance on tough applications and stainless steel



Merit Ceramic Plus Fiber Discs

- Ceramic alumina grain with self-lubricating supersize treatment, resin fiber discs resist heat build-up, cut aggressively, and are perfect for those applications that require a firm aggressive disc
- Heaviest fiber backing, greater durability, longest life, and edge-fray resistance on tough applications and stainless steel



Merit Zirconia Fiber Discs

- New, improved zirconia alumina provides a constant supply of sharp cutting edges for a fast, aggressive cutting action
- Heaviest fiber backing, greater durability, longer life, and edge fray resistance on tough applications and stainless steel



Norton NorKut Discs

- NorZon grain is resin bonded to a unique polymer backing which resists cracking and breaking and can be trimmed to the 1" core
- Use the cores to grind "pinch" welds and other hard-to-reach areas
- Used with a quick change mandrel: 7/16"-20 threaded for hand-held pneumatic grinders or 1/4" mandrel for automotive drills

AVAILABILITY

TIER:	BEST
BRAND:	Norton
ABRASIVE:	Ceramic Alumina
BACKING:	Fiber – Heavy Duty
OTHER:	Supersized
ATTACHMENT:	TR (Type III)



SIZE (D)	GRIT	STD. PKG.	PART NO.
2	36	25	66261058704
	50	25	66261058705
	60	25	66261058706
	80	25	66261058707
3	36	25	66261058708
	50	25	66261058709
	60	25	66261058711
	80	25	66261058712

AVAILABILITY

TIER:	BEST	BEST
BRAND:	Merit	Merit
ABRASIVE:	Ceramic Alumina	Ceramic Alumina
BACKING:	Fiber – Heavy Duty	Fiber – Heavy Duty
OTHER:	Supersized	Supersized
ATTACHMENT:	TS (Type II)	TR (Type III)



SIZE (D)	GRIT	STD. PKG.	PART NO.	PART NO.
2	36	100	08834165611	08834166041
	50		08834165613	08834166043
	60		08834166226	08834166044
	80		08834166227	08834166045
	120		08834165616	08834166046
3	36	50	08834166035	08834166219
	50		08834166037	08834166220
	60		08834166038	08834166221
	80		08834166039	08834166222
	120		08834166040	08834166223

AVAILABILITY

TIER:	BETTER	BETTER
BRAND:	Merit	Merit
ABRASIVE:	Zirconia Alumina	Zirconia Alumina
BACKING:	Fiber – Heavy Duty	Fiber – Heavy Duty
OTHER:	Supersized	Supersized
ATTACHMENT:	TS (Type II)	TR (Type III)



SIZE (D)	GRIT	STD. PKG.	PART NO.	PART NO.
2	50	100	08834167802	08834167812
	60		08834167803	
3	50	50	08834167807	
	80		08834167809	

AVAILABILITY

TIER:	BETTER
BRAND:	Norton
ABRASIVE:	Zirconia Alumina
BACKING:	Extra HD Polymer
ATTACHMENT:	Threaded Hole

SIZE (D)	GRIT	STD. PKG.	PART NO.
3	24	20	63642503656
	36		63642503657
	50		63642503658
7/16"-20 Mandrel	-	5	63642503659
1/4" Mandrel	-	5	63642503660



Merit Mini Zirconia Flap Discs

- High performance zirconia alumina abrasive provides maximum cut rate and life
- Layered flaps wear away evenly, producing a high-quality and consistent finish

AVAILABILITY

TIER:	BEST	BEST
BRAND:	Merit	Merit
ABRASIVE:	Zirconia Alumina	Zirconia Alumina
FLAP:	Cotton	Cotton
BACKING MATERIAL:	X-Heavy Duty Plastic	X-Heavy Duty Plastic
ATTACHMENT:	TS (Type II)	TR (Type III)

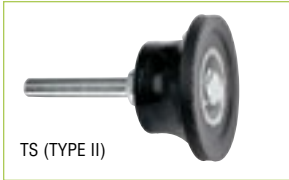

SIZE (D)	GRIT	STD. PKG.	PART NO.	PART NO.
2	36	10	08834195020	08834194550
	40		08834195021	08834194551
	60		08834195022	08834194552
	80		08834195023	08834194553
	120		08834195024	08834194554
3	36	10	08834195035	08834194563
	40		08834195036	08834194564
	60		08834195037	08834194565
	80		08834195038	08834194566
	120		08834195039	08834194567

DESCRIPTION	STD. PKG.	PART NO.
Mini Flap Disc 2" & 3" TS (Type II) Back-up Pad	1	08834168539
Mini Flap Disc 2" & 3" TR (Type III) Back-up Pad	1	08834160172



Norton Blaze R980P Cloth Discs

- Next-generation, Norton SG ceramic alumina grain with self-lubricating, supersize treatment provides coolest cut; significantly faster cut rates
- 3-ply heavy-duty laminate discs (Y-wt. polyester yellow backing) are more aggressive; for greatest durability, longest life, and edge-fray resistance on tough applications and stainless steel
- 2-ply laminate discs (red backing) provide durability and long life, but are more conformable and flexible

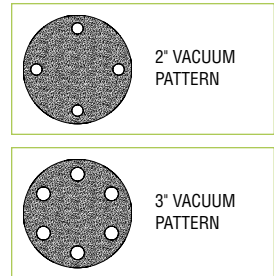

AVAILABILITY

TIER:	BEST	BEST	BEST	BEST	BEST
BRAND:	Norton	Norton	Norton	Norton	Norton
ABRASIVE:	Ceramic Alumina	Ceramic Alumina	Ceramic Alumina	Ceramic Alumina	Ceramic Alumina
BACKING:	Polyester Heavy Duty	Polyester Conformable	Polyester Heavy Duty	Polyester Heavy Duty Vacuum	Polyester Conformable
OTHER:	Supersized	Supersized	Supersized	Supersized	Supersized
ATTACHMENT:	TS (Type II)	TS (Type II)	TR (Type III)	TR (Type III)	TR (Type III)



SIZE (D)	GRIT	STD. PKG.	PART NO.	PART NO.	PART NO.	PART NO.	PART NO.
1-1/2	36	100	66261162307	63642595401	66261162308		63642595465
	50		66261162309	63642595446	66261162310		63642595467
	60		66261162311	63642595447	66261162312		63642595468
	80		66261162313	63642595450	66261162314		63642595469
	120		66261043379	66261043416	66261043380		66261043417
2	36	25	66261162317	63642595452	66261162318		63642595470
	50		66261162319	63642595456	66261162320		63642595472
	60		66261162321	63642595458	66261162322	66254481589	63642595476
	80		66261162323	63642595459	66261162324	66254481590	63642595478
	100		66261043382	66261043418	66261043383		66261043419
120	66261043384	66261043420	66261043386	66254481591	66261043421		
3	36	25	66261162327	63642595460	66261162328		63642595479
	50		66261162329	63642595462	66261162330		63642595480
	60		66261162331	63642595463	66261162332	66254481705	63642595481
	80		66261162333	63642595464	66261162334	66254481707	63642595493
	100		66261043389	66261043422	66261043390		66261043423
120	66261043391	66261043424	66261043392	66254481708	66261043425		



Merit Ceramic Plus Cloth Discs

- Ceramic alumina grain provides exceptional life and value, especially on hard-to-grind alloys
- The supersize grinding aid produces longer life and cooler cut
- Strong, Y-wt. 2-ply polyester backing provides excellent durability and grain adhesion

AVAILABILITY

TIER:	BEST	BEST	BEST
BRAND:	Merit	Merit	Merit
ABRASIVE:	Ceramic Alumina	Ceramic Alumina	Ceramic Alumina
BACKING:	Polyester Standard	Polyester Standard	Polyester Standard
OTHER:	Supersized	Supersized	Supersized
ATTACHMENT:	TS (Type II)	TR (Type III)	TP (Type I)





SIZE (D)	GRIT	STD. PKG.	PART NO.	PART NO.	PART NO.
9/16	36	100	08834163315		08834163000
	40		08834163316		
	50		08834163317		
	60		08834163318		08834163005
	80		08834163319		08834163014
	100		08834163434		08834163433
	120		08834163320		08834163017
3/4	36	100	08834163321	08834163392	08834163020
	40			08834163393	08834163021
	50		08834163324	08834163394	08834163022
	60		08834162239	08834163395	08834163023
	80		08834163339	08834163396	08834163024
	100		66254410755	08834163438	
	120		08834163362	08834163397	08834163027
1	36	100	08834163374	08834163398	08834163028
	40		08834163375	08834163400	08834163030
	50		08834163376	08834163401	
	60		08834162240	08834163402	08834163042
	80		08834163378	08834163403	08834163043
	100		08834163440	08834163441	08834163439
	120		08834163379	08834163404	08834163112
1-1/2	36	100	08834163421	08834163405	08834163113
	40			08834163406	08834163114
	50		08834163252	08834162620	08834163115
	60		08834160463	08834163407	08834163116
	80		08834163273	08834163408	08834163117
	100		08834163443	08834163444	08834163442
	120		08834168653	08834163409	08834168650
2	36	100	08834163118	08834160449	08834163119
	40				08834163120
	50		08834163259	08834163411	08834163121
	60		08834163551	08834163412	08834163231
	80		08834163381	08834165615	08834163219
	100			08834163447	
	120		08834163382	08834168657	08834168651
3	36	50	08834163383	08834160458	08834163238
	40			08834163413	08834163245
	50	100	08834163385	08834163414	08834168275
	60		08834163386	08834163415	08834163266
	80		08834163387	08834168178	08834169701
	100				08834163448
	120		08834168655	08834168658	08834168652
4	36	50	08834162742	08834163416	08834163280
	40		08834163388	08834163417	
	50		08834162743	08834163418	
	60		08834163389	08834162992	08834163301
	80		08834163390	08834163419	
	100		08834163452	08834163453	08834163451
	120		08834163391	08834163420	08834163314



Merit Zirconia Plus Cloth Discs

AVAILABILITY

TIER:	BETTER	BETTER	BETTER
BRAND:	Merit	Merit	Merit
ABRASIVE:	Zirconia Alumina	Zirconia Alumina	Zirconia Alumina
BACKING:	Polyester Standard	Polyester Standard	Polyester Standard
OTHER:	Supersized	Supersized	Supersized
ATTACHMENT:	TS (Type II) 	TR (Type III) 	TP (Type I) 

- Ideal product for demanding grinding applications
- Grinding aid results in cooler cut on stainless steel, titanium and other exotic alloys
- Strong, Y-wt., 2-ply polyester backing provides excellent durability and grain adhesion
- Lubricated supersize coat runs cooler



SIZE (D)	GRIT	STD. PKG.	PART NO.	PART NO.	PART NO.
1	36	100		08834167093	08834167009
	40		08834167052	08834167094	08834167010
	50		08834167053	08834167095	08834167011
	60		08834167054	08834167096	08834167012
	80		08834167055	08834167097	08834167013
	120		08834167057	08834167099	08834167015
1-1/2	36	100	08834167058	08834167100	08834167016
	40		08834167059	08834167101	08834167017
	50		08834167060	08834167102	08834167018
	60		08834167061	08834167103	08834167019
	80		08834167062	08834167104	08834167020
	120		08834167064	08834167106	
2	36	100	08834167065	08834167107	08834167023
	40		08834167066	08834167108	
	50		08834165583	08834167109	08834167025
	60		08834167068	08834167110	08834167026
	80		08834167069	08834167111	08834167027
	120		08834167071	08834167113	08834167029
3	36	50	08834167072	08834167114	08834167030
	40		08834167073	08834167115	
	50		08834167074	08834167116	
	60		08834167075	08834167117	08834167033
	80		08834167076	08834167118	08834167034
	120		08834167078	08834167120	08834167036
4	36	50	08834167079		
	40		08834167080		
	50		08834167081		08834167040
	60		08834167082		
	80		08834167083		
	120		08834167085		08834167043



Norton BlueFire R884P Cloth Discs

- Premium, versatile, self-sharpening zirconia alumina plus grain provides aggressive cut and up to 30% longer life than competitive zirconia alumina products
- Upgraded resin bond improves base adhesion and reduces grain shedding
- New grain coating results in longer life and faster cut rate
- Semi-open coat retards loading on soft metals (aluminum, brass, and bronze) and wood, as well as stainless steel and carbon steel
- Durable, Y-wt., 2-ply polyester backing stands up to demanding applications: high-pressure and hard-to-grind exotic alloys

AVAILABILITY

TIER:	BETTER	BETTER
BRAND:	Norton	Norton
ABRASIVE:	Zirconia Alumina	Zirconia Alumina
BACKING:	Polyester Standard	Polyester Standard
ATTACHMENT:	TS (Type II) 	TR (Type III) 

SIZE (D)	GRIT	STD. PKG.	PART NO.	PART NO.
1	50	100	66261138609	
	60		66261138608	
	80		66261138607	
1-1/2	24	100	66261138625	
	36		66261138624	66261121041
	50		66261138622	
	60		66261138621	66261121043
	80		66261138620	66261121044
2	24	25	66261138638	66261138672
	36		66261138637	66261138671
	50		66261138635	66261138670
	60		66261138634	66261121048
	80		66261138633	66261121049
3	24	25	66261138665	66261138675
	36		66261138664	66261138674
	50		66261138662	66261138673
	60		66261138661	66261121053
	80		66261138660	66261121054
4	36	25	66261138683	
	50		66261138681	
	60		66261137343	
	80		66261138679	

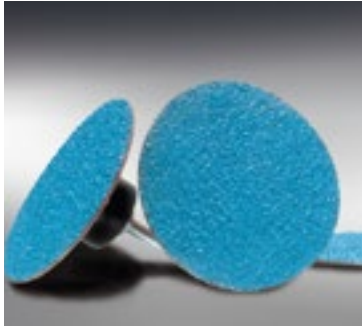

- Self-sharpening, zirconia alumina abrasive provides cooler cut, longer life
- Strong, Y-wt., 2-ply cotton backing construction for extended durability and reduced edge-wear

Merit Zirconia Cloth Discs

AVAILABILITY

<i>TIER:</i>	BETTER	BETTER	BETTER
<i>BRAND:</i>	Merit	Merit	Merit
<i>ABRASIVE:</i>	Zirconia Alumina	Zirconia Alumina	Zirconia Alumina
<i>BACKING:</i>	Cotton Standard	Cotton Standard	Cotton Standard
<i>ATTACHMENT:</i>	TS (Type II)	TR (Type III)	TP (Type I)



SIZE (D)	GRIT	STD. PKG.	PART NO.	PART NO.	PART NO.
1	40	100	08834165327	08834164591	
	60		08834165329	08834164597	
	80		08834165330	08834164304	08834166132
1-1/2	36	100	08834165341	08834166263	08834161366
	40		08834165342	08834164598	
	50		08834165343		
	60		08834165344	08834164599	
	80		08834165345	08834161688	
2	36	100	08834165356	08834164208	08834166134
	40		08834165357	08834164600	
	50		08834165358	08834161534	
	60		08834165359	08834161116	08834166137
	80		08834165360	08834166198	08834166138
3	36	50	08834165371	08834166264	
	40		08834165372		08834166141
	50		08834165373	08834161535	08834166142
	60		08834165374	08834166259	08834166143
	80		08834165375	08834166269	08834166144



- Premium abrasive and aluminum oxide blend for aggressive cut and longer life than competitive aluminum oxide discs
- Durable Y-wt. 2-ply polyester backing and new grain coating for longer life and faster cut rate on moderately-demanding applications
- Great for difficult-to-grind materials (aluminum, brass, bronze, stainless, carbon steel, and titanium) and applications requiring an economical option

Norton Neon R766 Aluminum Oxide Cloth Discs

AVAILABILITY

<i>TIER:</i>	GOOD	GOOD	GOOD
<i>BRAND:</i>	Norton	Norton	Norton
<i>ABRASIVE:</i>	Aluminum Oxide	Aluminum Oxide	Aluminum Oxide
<i>BACKING:</i>	Polyester Standard	Polyester Standard	Polyester Standard
<i>ATTACHMENT:</i>	TS (Type II)	TR (Type III)	TP (Type I)





SIZE (D)	GRIT	STD. PKG.	PART NO.	PART NO.	PART NO.
3/4	36	100	66623318938	66623318944	66623318933
	40		66623318939	66623318945	66623318934
	50		66623318941	66623318946	66623318935
	60		66623318942	66623318947	66623318936
	80		66623318943	66623318949	66623318937
1	36	100	66623318957	66623318962	66623318950
	40		66623318958	66623318963	66623318951
	50		66623318959	66623318964	66623318952
	60		66623318960	66623318965	66623318953
	80		66623318961	66623318966	66623318956
1-1/2	36	100	66623318972	66623318977	66623318967
	40		66623318973	66623318978	66623318968
	50		66623318974	66623318979	66623318969
	60		66623318975	66623318980	66623318970
	80		66623318976	66623318981	66623318971
2	24	100	66623319011	66623319013	66623319010
	36		66623318999	66623319005	66623318993
	40		66623319000	66623319006	66623318994
	50		66623319001	66623319007	66623318995
	60		66623319003	66623319008	66623318996
3	24	50	66623319004	66623319009	66623318997
	36		66623319020	66623319026	66623319014
	40		66623319021	66623319027	66623319015
	50		66623319022	66623319028	66623319016
	60		66623319023	66623319029	66623319017
4	24	50	66623319024	66623319030	66623319018
	36		66623319025	66623319031	66623319019
	40		66623319034	66623319036	66623319032
	50		66623319035	66623319037	66623319033



- Aluminum Oxide Plus discs feature a grinding aid
- They run cooler and more efficiently for grinding exotic alloys
- Strong, Y-wt., 2-ply polyester backing construction for extended durability and reduced edge-wear

Merit Aluminum Oxide Plus Cloth Discs

AVAILABILITY

TIER:	GOOD	GOOD	GOOD
BRAND:	Merit	Merit	Merit
ABRASIVE:	Aluminum Oxide	Aluminum Oxide	Aluminum Oxide
BACKING:	Polyester Standard	Polyester Standard	Polyester Standard
OTHER:	Supersized	Supersized	Supersized
ATTACHMENT:	TS (Type II) 	TR (Type III) 	TP (Type I) 



SIZE (D)	GRIT	STD. PKG.	PART NO.	PART NO.	PART NO.
3/4	36	100	08834167462	08834164467	08834164345
	50		08834167464	08834164469	
	60		08834167465	08834164470	08834164349
	80		08834167466	08834164471	08834164350
	120		08834167468	08834164473	08834164361
1	36	100	08834167477	08834164475	08834164363
	40			08834164364	
	50		08834167479	08834164477	08834164365
	60		08834167480	08834164478	08834164366
	80		08834167481	08834164479	08834164368
1-1/2	36	100	08834167483	08834164481	08834164370
	40		08834166881	08834164483	08834164392
	50		08834166882	08834164484	08834164393
	60		08834166883		08834164394
	80		08834166884	08834164486	08834164395
2	36	100	08834166885	08834164487	08834164396
	40		08834166887	08834164489	08834164398
	50		08834166896	08834164491	08834164400
	60		08834166897	08834164492	08834164401
	80		08834166898	08834164493	08834164402
3	36	50	08834166899	08834164494	08834164403
	40		08834166900	08834164495	08834164404
	50		08834166902	08834164496	08834164428
	60		08834166911	08834164498	08834164430
	80		08834166912	08834164499	08834164431
4	36	50	08834166913	08834164500	08834164432
	40		08834166914	08834164501	08834164433
	50		08834166915	08834164502	08834164434
	60		08834166917	08834164509	08834164436
	80		08834163959	08834164511	08834164459
	36	50	08834163960	08834164525	08834164460
	40		08834163961		
	50		08834163962	08834164527	08834164462
	60		08834163963	08834164536	
	80		08834163965		



Merit Metal Aluminum Oxide Cloth Discs

- Versatile aluminum oxide abrasive is tough and durable with aggressive cutting action
- Heavyweight, but smooth, cotton backing for roughing and blending
- Available in coarse grits for light to medium grinding, medium grits for blending, and fine finishing grits
- Competitive initial price point makes this product the best starting specification for end-users unable to measure performance

AVAILABILITY

TIER:	GOOD	GOOD
BRAND:	Merit	Merit
ABRASIVE:	Aluminum Oxide	Aluminum Oxide
BACKING:	Cotton Standard	Cotton Standard
ATTACHMENT:	TS (Type II) 	TR (Type III) 

SIZE (D)	GRIT	STD. PKG.	PART NO.	PART NO.
2	36	100	66254468890	66254469256
	40		66254468891	66254469257
	50		66254469251	66254469258
	60		66254469252	66254469259
	80		66254469253	66254469260
	100		66254469254	66254469261
3	36	50	66254469255	66254469262
	40		66254469263	66254469270
	50		66254469264	66254469271
	60		66254469265	66254469272
	80		66254469266	66254469273
	100		66254469267	66254469274
	120		66254469268	66254469275
			66254469269	66254469276



Norton Metalite R228 Aluminum Oxide Cloth Discs

- Premium aluminum oxide abrasive provides long life
- Strong, X-wt., 2-ply cotton backing construction for extended durability and reduced edge-wear
- Ideal for aggressive stock removal applications
- Resistant to heat

TIER:	GOOD
BRAND:	Norton
ABRASIVE:	Aluminum Oxide
BACKING:	Cotton Standard
OTHER:	Vacuum
ATTACHMENT:	TR (Type III)



AVAILABILITY

SIZE (D)	GRIT	STD. PKG.	PART NO.
2	60	100	66254481586
	80		66254481587
	120		66254481588
3	60	50	66254481702
	80		66254481703
	120		66254481704



Merit Silicon Carbide Cloth Discs

- Sharp, silicon carbide abrasive on X-wt. backing provides high initial cut and penetration for nonferrous materials

TIER:	GOOD	GOOD	GOOD
BRAND:	Merit	Merit	Merit
ABRASIVE:	Silicon Carbide	Silicon Carbide	Silicon Carbide
BACKING:	Cotton Standard	Cotton Standard	Cotton Standard
ATTACHMENT:	TS (Type II)	TR (Type III)	TP (Type I)



AVAILABILITY

SIZE (D)	GRIT	STD. PKG.	PART NO.	PART NO.	PART NO.
2	40	100	08834165252	08834164275	08834162166
	60		08834165254	08834164163	08834162168
	80		08834165255	08834166155	08834162169
	120		08834165257	08834164837	08834162171
	180		08834165259	08834167313	08834162173
3	40	50	08834165267	08834164277	
	60		08834165269	08834164850	
	80		08834165270	08834166159	08834162188
	120		08834165272	08834166160	08834162190
	180		08834165274	08834168177	08834164971





Merit Quick-Change Test Kit "D"

- Part No. 08834165001
- Includes 150 discs, assorted grits, in 1", 2", and 3" diameters and 3" back-up pads
- Primarily aluminum oxide cloth quick-change discs
- Several zirconia alumina and FlexEdge discs are included



Merit Aluminum Oxide Cloth Discs

AVAILABILITY

TIER:	GOOD	GOOD	GOOD
BRAND:	Merit	Merit	Merit
ABRASIVE:	Aluminum Oxide	Aluminum Oxide	Aluminum Oxide
BACKING:	Polyester Standard	Polyester Standard	Polyester Standard
ATTACHMENT:	TS (Type II) 	TR (Type III) 	TP (Type I) 

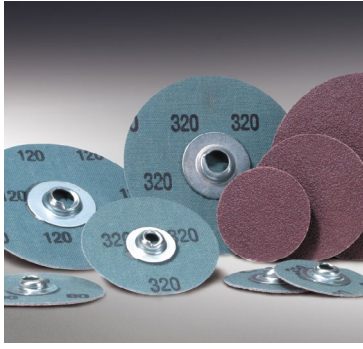

- Premium abrasive and aluminum oxide blend for aggressive cut and longer life than competitive aluminum oxide discs
- Durable Y-wt. 2-ply polyester backing and new grain coating for longer life and faster cut rate on moderately-demanding applications
- Great for difficult-to-grind materials (aluminum, brass, bronze, stainless, carbon steel, and titanium) and applications requiring an economical option

SIZE (D)	GRIT	STD. PKG.	PART NO.	PART NO.	PART NO.
3/4	24	100	69957399601	69957399669	69957399737
	36		69957399602	69957399670	69957399738
	40		69957399603	69957399671	69957399739
	50		69957399604	69957399672	69957399740
	60		69957399605	69957399673	69957399741
	80		69957399606	69957399674	69957399742
	100		69957399607	69957399675	69957399743
	120		69957399608	69957399676	69957399744
	150		69957399609	69957399677	69957399745
	180		69957399610	69957399678	69957399746
	240		69957399611	69957399679	69957399747
	320		69957399612	69957399680	69957399748
1	24	100	69957399613	69957399681	69957399749
	36		69957399614	69957399682	69957399750
	40		69957399615	69957399683	69957399751
	50		69957399616	69957399684	69957399752
	60		69957399617	69957399685	69957399753
	80		69957399618	69957399686	69957399754
	100		69957399619	69957399687	69957399755
	120		69957399620	69957399688	69957399756
	150		69957399621	69957399689	69957399757
	180		69957399622	69957399690	69957399758
	240		69957399623	69957399691	69957399759
	320		69957399624	69957399692	69957399760
1-1/2	24	100	69957399625	69957399693	69957399761
	36		69957399626	69957399694	69957399762
	40		69957399627	69957399695	69957399763
	50		69957399628	69957399696	69957399764
	60		69957399629	69957399697	69957399765
	80		69957399630	69957399698	69957399766
	100		69957399631	69957399699	69957399767
	120		69957399632	69957399700	69957399768
	150		69957399633	69957399701	69957399769
	180		69957399634	69957399702	69957399770
	240		69957399635	69957399703	69957399771
	320		69957399636	69957399704	69957399772
2	24	100	69957399637	69957399705	69957399773
	36		69957399638	69957399706	69957399774
	40		69957399639	69957399707	69957399775
	50		69957399640	69957399708	69957399776
	60		69957399641	69957399709	69957399777
	80		69957399642	69957399710	69957399778
	100		69957399643	69957399711	69957399779
	120		69957399644	69957399712	69957399780
	150		69957399645	69957399713	69957399781
	180		69957399646	69957399714	69957399782
	240		69957399647	69957399715	69957399783
	320		69957399648	69957399716	69957399784
3	24	50	69957399649	69957399717	69957399785
	36		69957399650	69957399718	69957399786
	40		69957399651	69957399719	69957399787
	50		69957399652	69957399720	69957399788
	60		69957399653	69957399721	69957399789
	80		69957399654	69957399722	69957399790
	100		69957399655	69957399723	69957399791
	120		69957399656	69957399724	69957399792
	150		69957399657	69957399725	69957399793
	180		69957399658	69957399726	69957399794
	240		69957399659	69957399727	69957399795
	320		69957399660	69957399728	69957399796
4	36	50	69957399661	69957399729	69957399797
	40		69957399662	69957399730	69957399798
	50		69957399663	69957399731	69957399799
	60		69957399664	69957399732	69957399800
	80		69957399665	69957399733	69957399801
	100		69957399666	69957399734	69957399802
	120		69957399667	69957399735	69957399803
180	69957399668	69957399736	69957399804		



Merit Aluminum Oxide *fx* and FlexEdge Cloth Discs

AVAILABILITY

TIER:	GOOD	GOOD	GOOD
BRAND:	Merit	Merit	Merit
ABRASIVE:	Aluminum Oxide	Aluminum Oxide	Aluminum Oxide
BACKING:	Cotton Flexible (<i>fx</i>)	Cotton FlexEdge	Cotton FlexEdge
ATTACHMENT:	TS (Type II) 	TS (Type II) 	TP (Type I) 

SIZE (D)	GRIT	STD. PKG.	PART NO.	PART NO.	PART NO.
1	24	100	08834168881		
	36		08834168479		
	40		08834168480		
	50		08834168481		08834164309
	60		08834168431	08834160394	08834164296
	80		08834168432	08834160395	
	100		08834168482	08834160396	08834164215
	120		08834168434	08834160397	
	150		08834168483		
	180		08834168484		
	240		08834168485		
	320		08834168486		
	1-1/2		24	100	08834168882
36		08834168487			
40		08834168488			
50		08834168489	08834163713		08834166375
60		08834168435	08834167333		
80		08834168436	08834160399		
100		08834168490	08834163714		
120		08834168437	08834160401		
150		08834168491			
180		08834168492	08834160402		08834164320
240		08834168493			
320		08834168494			
2		24	100		08834168883
	36	08834168495			
	40	08834168496			
	50	08834168497		08834163721	08834164333
	60	08834168438		08834160403	08834164334
	80	08834168439		08834160404	08834164335
	100	08834168498		08834166959	
	120	08834168440		08834167363	08834164337
	150	08834168499			
	180	08834168500		08834160405	08834164339
	240	08834168501			
	320	08834168502			
	3	24		50	08834168884
36		08834168503			
40		08834168504			
50		08834168505	08834163728		08834164352
60		08834168441	08834160406		08834164353
80		08834168442	08834161282		08834164354
100		08834168506	08834166974		08834164355
120		08834168443	08834163729		08834164356
150		08834168507			
180		08834168508	08834160407		08834164358
240		08834168509			
320		08834168510			
Back-up Pad for 3" FlexEdge Discs Max. RPM 30,000			1		08834168539

fx (conformable)

- These (flexible) aluminum oxide discs are designed for general purpose deburring and blending on contoured surfaces

FlexEdge

- Manufactured with special flexible aluminum oxide abrasive cloth where the outer 3/8" is more flexible than the rest of the disc
- Designed for softer metals where standard (*fx*) discs can gouge and for contour grinding of structural pieces
- Used in aircraft and aerospace manufacturing for structural hand polishing
- When using back-up pads for FlexEdge discs, order (use) one size smaller than the disc

TECHtip

Avoid gouging on contours by using a smaller size back-up pad than the diameter of the discs, such as 1-1/2" back-up pad for 2" discs. For 3" discs and larger, order the special FlexEdge back-up pad that is 2" in diameter but contains the cam lock fastener for 3" and larger discs.



Quick-Change Back-up Pads

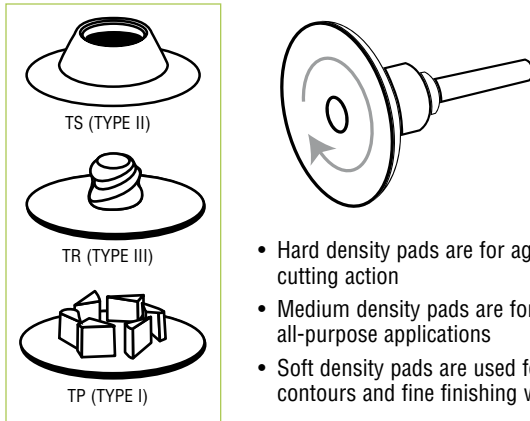

- Hard density pads are for aggressive cutting action
- Medium density pads are for all-purpose applications
- Soft density pads are used for contours and fine finishing work

DIAMETER/RPM	DENSITY	TS (TYPE II)	TR (TYPE III)	TP (TYPE I)
Quick-Change Back-up Pads				
9/16 40,000 RPM		66261054014		66261054013
3/4 40,000 RPM	Medium	08834164206	08834164038	08834164001
1 40,000 RPM	Medium	08834164651	08834164037	08834164002
1-1/2 30,000 RPM	Hard	08834164622	08834164640	08834163996
	Medium	08834164146	08834161174	08834164003
2 30,000 RPM	Hard	08834164624	08834164643	08834163997
	Medium	08834164198	08834164922	08834164004
	Soft	08834161625	08834164641	08834163949
3 20,000 RPM	Hard	08834161626	08834164036	08834163998
	Medium	08834164113	08834164949	08834164005
	Soft	08834164626	08834164644	08834163948
4 15,000 RPM	Medium	08834164135	08834164655	08834164006

ALL QUICK-CHANGE BACK-UP PADS HAVE A 1/4" SOLID STEEL SHANK. STD. PKG. = 1

Replacement Medium Density Rubber Pads for Quick-Change Back-up Pads

DIAMETER	MODEL NO.	TP (TYPE I)
Quick-Change Replacement Rubber Back-up Pads		
3/4	RR75	08834164008
1	RR10	08834164009
2	RR20	08834164011
3	RR30	08834164012
4	RR40	08834164013

WHEN THE RUBBER PAD HAS WORN AWAY, BUT THE STEEL COMPONENTS OF YOUR QUICK-CHANGE BACK-UP ARE STILL SERVICEABLE, ORDER THESE REPLACEMENT RUBBER PADS. STD. PKG. = 1

Replacement Assemblies and Shanks for Quick-Change Back-up Pad

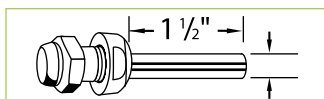

DESCRIPTION	STD. PKG.	PART NO.
Replacement Mandrels and Nut Assembly		
TP (Type I) Assembly RMN1 for 3/4 - 2	1	08834164015
TP (Type I) Assembly RMN3 for 3 - 4	1	08834164016
TS (Type II) & TR (Type III) Replacement 1/4" Shank	1	08834164303

ASSEMBLIES REPLACE ALL THE STEEL COMPONENTS OF A QUICK-CHANGE BACK-UP PAD. THIS SHANK REPLACES THE SCREW-IN 1/4" SOLID STEEL SHANK ONLY.

Extension Mandrels and Assembly

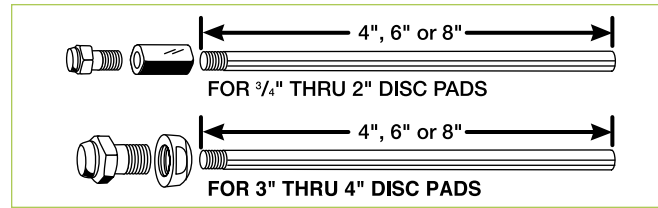

DIAMETER	MODEL NO.	LENGTH	STD. PKG.	PART NO.
Extension Mandrels and Assembly – TP (Type I)				
3/4 - 2	EMN-14	4"	1	08834164017
3/4 - 2	EMN-16	6"	1	08834164018
3/4 - 2	EMN-18	8"	1	08834164019
3 - 4	EMN-34	4"	1	08834164020
3 - 4	EMN-36	6"	1	08834164026
3 - 4	EMN-38	8"	1	08834164021

MNA-1 Pad Adapters

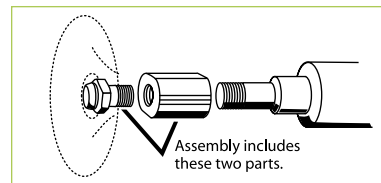

DISC DIAMETER	MODEL NO.	STD. PKG.	PART NO.
MNA-1 Pad Adapters – TP (Type I)			
3/4 - 2	MNA 1/4-20 THD.	1	08834161176
3/4 - 2	MNA 3/8-24	1	08834164055
3/4 - 2	MNA 5/8-11	1	08834163001
3 - 4	MNA 1/4-20	1	08834163002
3 - 4	MNA 3/8-24	1	08834164041
3 - 4	MNA 5/8-11	1	08834164028

CONVERT A TP (TYPE I) BACK-UP PAD 1/4" DIAMETER SOLID SHANK TO A THREADED SHANK

MNA-23 Pad Adapters

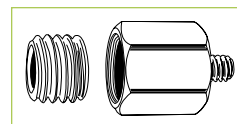

DISC DIAMETER	MODEL NO.	STD. PKG.	PART NO.
MNA-23 Pad Adapters – TS (Type II) and TR (type III)			
3/4 - 4	MNA-23 3/8-24 5/8"-11 THD.	1	08834162764

FOR USE ON A RIGHT ANGLE GRINDER: CONVERT TS (TYPE II) AND TR (TYPE III) BACK-UP PAD 1/4" DIAMETER SOLID SHANKS TO THREADED SHANKS. THE LARGER 5/8-11 ADAPTER (FOR 4-1/2" DISCS) IS USED ALONE TO CONVERT TO A 5/8-11 THREAD. THE 3/8-24 INSERT (FOR 4" DISCS) IS SCREWED INTO THE 5/8-11 ADAPTER TO CREATE A 3/8-24 THREAD ADAPTER.

1/4" Diameter Extension Mandrel

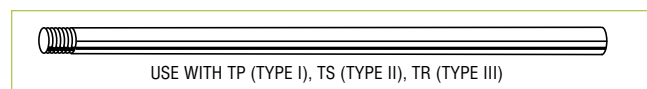

MODEL NO.	LENGTH	STD. PKG.	PART NO.
1/4" Diameter Extension Mandrel 1/4-20 Thread			
EM-144	4	1	08834154185
EM-146	6	1	08834154186
EM-148	8	1	08834154187



CATEGORY DEFINITION

Paper sheets and rolls are engineered for optimum performance when sanding metal, wood, composites and painted surfaces. The sheets are packed in protective packaging to eliminate waste and permit easy, neat storage.

Categories:	Stearated (non-loading) Ceramic Alumina, Aluminum Oxide and Silicon Carbide Waterproof Aluminum Oxide and Silicon Carbide All Purpose Aluminum Oxide and Garnet Heavyweight Zirconia Alumina
Applications:	Light-duty metal sanding, primer sanding, defect removal from painted surfaces, filler sanding, sanding and finishing of composites and fiberglass, bare wood sanding, sanding between sealer coats
Size Range:	Full Sheets, Cut Sheets, File Strips and Rolls
Grit Range:	36 – 2500
Abrasive Grain:	Ceramic Alumina, Zirconia Alumina, Aluminum Oxide, Silicon Carbide, and Garnet

MATERIAL-TO-PRODUCT RECOMMENDATION GUIDE

	BEST Highest Productivity – Lowest Total Cost	BETTER Excellent Blend of Performance & Price	GOOD Consistent Performance – Low Initial Price
Unfinished Metal	A275	–	PB273
Primed / Painted Surfaces / Between Coats	A275	A475	PB273
Fiberglass / Composites	A275	A475	PB273
Bare Wood	A275	–	A511, A513, A514
Clear Coat Sanding	T214, T401	–	T461
Sealer Sanding	A275	A475	PB273
Lacquer Sanding	T214, T401	T414	T461
Wet Sanding	T214, T401	T414	T461
Paint Stripping	A259 (3X)	A475	A290
All Purpose Dry Sanding	A259 (3X)	–	A212, A213, A211

APPLICATION/GRIT RECOMMENDATION GUIDE

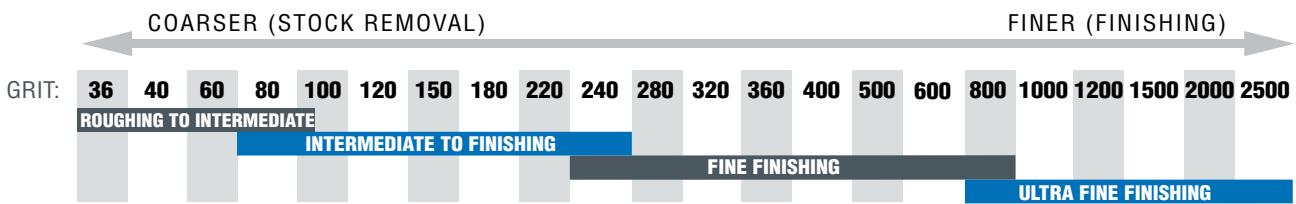

RECOMMENDED BACKING WEIGHT

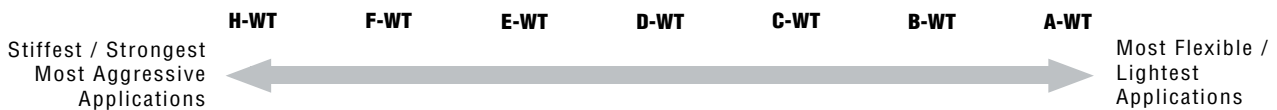



CROSS REFERENCE GUIDE

NORTON	3M	Hermes	Klingspor	Mirka	SIA	VSM
Stearted (Non-Loading)						
A975	734U, 735U, 765L, 334U	-	-	-	1950 siaspeed	-
A275 / A259 (3X)	216U, 334U	HC133	PS33	Royal, Royal Micro	1950 siaspeed	-
A475	405N, 414N, 415N/U	PSF-LL, SA168	PL35	Carat Flex, FineFlex	1701 sialac 1748 siarexx fine	CP131A
A290	236U	HCAB-LL	PS33, PL36	Bulldog Gold	1960 siarexx cut	KP911
PB273	Red, NX	-	PL36	GoldFlex	-	-
Waterproof						
T214	213Q	WAFlex28B	PS12	-	1913 siawat	-
T401	401Q	WSFlex16	PS11, PS14	Waterproof (A)	-	CP918A
T414	413Q	WSFlex16	PS11, PS14	Waterproof (A)	-	CP918A
T461	438Q, 431Q	WSFlex18C	PS11, PS14	-	1727 siawat	CP918C
All Purpose/Wood						
A211	230U, 240N, 346U	-	-	-	-	KP31C
A212	210N	HFB	PL31	-	-	-
A213	230N	HFB	PL31	-	-	KP31B
A511	110N	-	-	-	1400 sianor	-
A513	130N	GCAB	-	-	-	-
A514	140N	GCAB	-	-	-	-
Heavyweight Paper						
H875P	750U, 751U, 740I, 745I	-	-	Royal Coarse Cut	-	KP510E, KP709

Aluminum Oxide All-Purpose Sanding and Garnet Wood Sanding 9 x 11 Paper Sheets

AVAILABILITY
9 X 11
PAPER SHEETS

SIZE	GRIT	MIN./ STD. PKG.	JOBPACK							
			PART NO.	PART NO.	PART NO.	PART NO.	PART NO.	PART NO.	PART NO.	
9 x 11	36	25/125	66261100335			07660700361*				
	40		66261100330							
	50	50/250	66261100325			07660700360*				
	60		66261100320			07660701624*	66261101560			
	80		66261100315				66261101555	66261101505		07660701584*
	100	100/500		66261100295		07660700358*	66261101535	66261101500		07660701583*
	120			66261100290		07660700357*	66261101530	66261101495		07660701582*
	150			66261100285		07660700356*	66261101525	66261101490		07660701581*
	180				66261100245	07660700355*		66261101489		07660701580*
	220				07660700156	07660700354*		66261101488		07660701579*
	240									
	280									
	Asst•					07660700365*				

* PACKAGING STANDARDS: JOB PACKS: 25 SHEETS PER PACK / 10 PACKS PER STANDARD PACKAGE FOR A TOTAL OF 250 SHEETS

• ASSORTED CONTAINS 6 EACH OF 60, 100, 150 GRIT AND 7 EACH OF 220 GRIT



Stearated (Non-Loading) Aluminum Oxide and Silicon Carbide 9 x 11 Sheets

FEATURED PRODUCTS



NO-FIL NORTON ADALOX A275

THE BEST CHOICE FOR SANDING PAINTED SURFACES, COMPOSITES, PLASTICS OR ANY MATERIAL THAT TENDS TO LOAD

FEATURES

- Premium P-graded, heat-treated aluminum oxide abrasive
- Unique fiber-reinforced, B-wt latex-saturated backing
- Water-based stearate, non-pigmented, No-Fil coating
- Full resin adhesive bond

BENEFITS

- Superior life, fast cut rate, consistent finish
- 50-60% improvement in tear strength
- Exceptional flexibility, can be folded without cracking
- Provides maximum load resistance and extended life: no color transfer to work
- Provides exceptional resistance to abrasive grain shedding especially when folding to sand into corners; long life



NO-FIL NORTON DURITE A475

THE BETTER CHOICE FOR GEL COATS, HARD COMPOSITE SUBSTRATES, ABRASION-RESISTANT COATINGS, AND WOODWORKING APPLICATIONS

FEATURES

- P-graded, silicon carbide abrasive
- Water-based stearate, non-pigmented, No-Fil coating
- Fiber-reinforced, latex paper backing

BENEFITS

- Easy penetration of the hardest surfaces
- Resists loading for longest usable product life, no color transfer to work
- Provides flexibility and resistance to tearing

AVAILABILITY 9 X 11 PAPER SHEETS



TIER:	BEST	BEST	BETTER	GOOD
BRAND:	Norton	Norton	Norton	Merit
TRADENAME:	A275 NO-FIL	A259 (3X) NO-FIL	A475 NO-FIL	PB273 NO-FIL
ABRASIVE:	Aluminum Oxide	Aluminum Oxide	Silicon Carbide	Aluminum Oxide
BACKING WEIGHT:	B-Weight	B-Weight	B-Weight	B-Weight
OTHER:	P-Graded	P-Graded	P-Graded	P-Graded

SIZE	GRIT	MIN. / STD. PKG.	PART NO.	PART NO.	PART NO.	PART NO.
9 x 11	60	50/250		07660702642*		
	80		66261131634	07660702641*	66254487393	66623311878
	100	100/500	66261131633	07660702640*	66254487394	66623311877
	120		66261131632	07660702639*	66254487395	66623311876
	150		66261131631	07660702638*	66254487396	66623311875
	180		66261131630	07660702637*	66254487397	66623311874
	220		66261131629	07660702636*	66254487398	66623311873
	240		66261131628		66254487399	66623311879
	280		66261131627			
	320		66261131626	07660702633*	66254487400	66623311871
	400		66261131624	07660702632*		66623311870
	500		66261131623			
	600		66261131622			
	800		66261131621			
	1000	100/500	66261131620			
1200		66261131619				
1500		66261131618				

* PACKAGING STANDARDS: A259 (3X) JOB PACKS: 20 SHEETS PER PACK / 10 PACKS PER STANDARD PACKAGE FOR A TOTAL OF 200 SHEETS



Waterproof Aluminum Oxide and Silicon Carbide 9 x 11 Sheets

FEATURED PRODUCTS

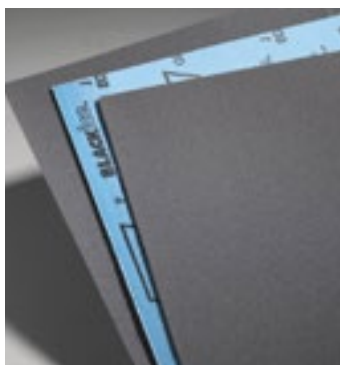

NORTON BLACK ICE T214 AND T401 WATERPROOF BEST CHOICE FOR ALL WET APPLICATIONS

FEATURES	BENEFITS
■ T214: Premium, P-graded, heat-treated aluminum oxide abrasive	■ Ultimate cut and life in wet applications
■ T401: Premium, ultra fine (1000 – 2500 JIS graded) silicon carbide abrasive	■ Ultimate finish in wet applications
■ Improved resin bond system	■ Long life in wet applications
■ High-strength B-wt, high-latex, waterproof paper backing	■ Ultimate flexibility, with wet-curl resistance
	■ Environmentally stable, resists humidity-caused curling

AVAILABILITY
9 X 11
PAPER SHEETS



TIER:	BEST	BEST	BETTER	GOOD
BRAND:	Norton	Norton	Norton	Norton
TRADENAME:	T214	T401	T414	T461
ABRASIVE:	Aluminum Oxide	Silicon Carbide	Silicon Carbide	Silicon Carbide
BACKING WEIGHT:	B-Weight	B-Weight	B-Weight	C-Weight
OTHER:	P-Graded	JIS Graded	CAMI Graded	CAMI Graded

SIZE	GRIT	MIN./STD. PKG.	PART NO.	PART NO.	PART NO.	PART NO.
9 x 11	60	50/250				66261101175
	80					66261101170
	100					66261101165
	120					66261101160
	150					66261101155
	180					66261101150
	220		66261139389		66261139367	
	240		66261139388		66261139366	66261130331
	280				66261139365	
	320		66261139386		66261139364	66261130332
	360				66261139363	
	400		66261139385		66261139362	66261130333
	500		66261139384		66261139361	
	600		66261139383		66261139360	66261130334
800	66261139382					
1000	50/250		66261139381			
1200			66261139380			
1500			66261139379			
2000			66261139378			
2500			66261139377			



Waterproof Sanding Blocks – with “grabbing” power

Dual Density Wet Sanding Block

- No adhesive required: simply wrap a 5-1/2" x 9" (9" x 11" cut in half) sheet around the block
- The dense side is for more aggressive blocking, while the soft side is for color sanding
- Equalizes sanding pressure for fine grit applications

Holey Block

- No adhesive required: simply wrap a 5-1/2" x 9" (9" x 11" cut in half) sheet around the block
- A rugged, semi-rigid, multi-purpose sanding block engineered for flat to medium curved surfaces
- A tactical hole pattern side provides numerous cutting edges to create a 30% faster cut rate
- The plain side provides firmness and a comfortable, easy-to-hold surface



DESCRIPTION	STD. PKG.	PART NO.
Wet Sanding Block	12	63642503728
Holey Block	8	63642503729



File Strips / Hand Sanding Cut Sheets / Rolls

FEATURED PRODUCTS

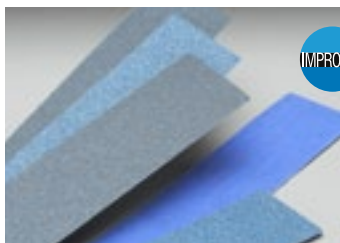

NORTON BLUEFIRE H875P
EXCELLENT FOR SOFT MATERIAL APPLICATIONS

FEATURES

- Patented zirconia abrasive
- Strong E-weight paper, latex impregnated
- Open coat design

BENEFITS

- Extended life over original NorZon products
- Increased durability and chip resistance, flexible
- Reduced loading; ideal for body filler, fiberglass and composite sanding

AVAILABILITY
PAPER FILE
STRIPS

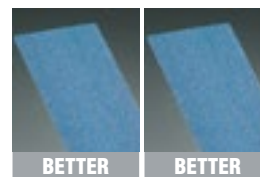
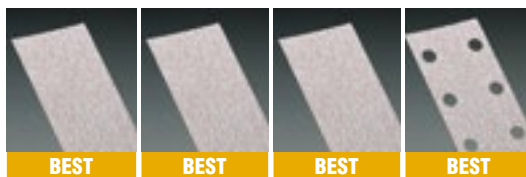

TIER:	BEST	BEST	BEST	BEST	BETTER	BETTER	BETTER
BRAND:	Norton	Norton	Norton	Norton	Norton	Norton	Norton
TRADENAME:	A275 NO-FIL	A275 NO-FIL	A275 NO-FIL	A275 NO-FIL	H875P	H875P	H875P
ABRASIVE:	A/O	A/O	A/O	A/O	Z/A	Z/A	Z/A
BACKING WEIGHT:	B-Weight	B-Weight	B-Weight	B-Weight	E-Weight	E-Weight	E-Weight
BACKING ATTACHMENT:	Non-PSA	PSA	Hook/Loop	Hook/Loop Vac	Non-PSA	PSA	Hook/Loop
OTHER:	P-Graded	P-Graded	P-Graded	P-Graded			

SIZE	GRIT	MIN/STD PKG	PART NO.	PART NO.	PART NO.	PART NO.	MIN/STD PKG	PART NO.	PART NO.	MIN/STD PKG	PART NO.
2-3/4 x 16	100	50/500				66261131657					
	120					66261131656					
	180					66261131654					
2-3/4 x 16-1/2	36	50/500					50/250		66261123610	25/125	66261123616
	40							66261123609	66261123615		
	80			66261131640	66261131646			66261123608	66261123614		
	100			66261131639	66261131645						
	120				66261131644						
	150			66261131637	66261131643						
	180			66261131636	66261131642						
220			66261131641								
2-3/4 x 17-1/2	36	50/500					50/250	66261123622			
	40							66261123621			
	80			66261131652				66261123620			
	100			66261131651				66261126512			
	120			66261131650							
	150			66261131649							
	180			66261131648							
220		66261131647				66261126511					



VACUUM HOLE PATTERN FOR
2-3/4 X 16 FILE STRIPS

Sanding Boards

PSA/Non-PSA Sanding Board

- This sanding board has a cushioned surface
- Spring clips mounted at each end securely hold 2-3/4" x 16-1/2" PSA file strips and 2-3/4" x 17-1/2" non-PSA file strips

Hook and Loop and Non-PSA Sanding Board

- Lightweight, rugged design for easy sanding of plastic fillers
- Spring clips mounted at each end securely hold 2-3/4" x 16-1/2" hook and loop file strips and 2-3/4" x 17-1/2" non-PSA file strips
- Air file shoe eliminates the need for clips. The quick-change backing positively locks and unlocks for fast use.

DESCRIPTION	STD. PKG.	PART NO.
Hook & Loop/Non-PSA File Strip Sanding Board	5	63642552836
Hook & Loop Air File Shoe	5	63642552835
PSA/Non-PSA File Strip Sanding Board	6	63642542724





AVAILABILITY
PAPER CUT SHEETS



TIER:	GOOD	GOOD	GOOD
BRAND:	Norton	Norton	Norton
TRADENAME:	A290 NO-FIL	A211	A213
ABRASIVE:	Aluminum Oxide	Aluminum Oxide	Aluminum Oxide
BACKING WEIGHT:	C-Weight	D-Weight	C-Weight
OTHER:	P-Graded	P-Graded	P-Graded

SIZE	GRIT	MIN./STD. PKG.	PART NO.	PART NO.	PART NO.
3-2/3 x 9	60	100/1000		66261102925	
	80		66261101119	66261102920	
	100				66261102900
	120				66261102895
	180		66261101124		
	220		66261101123		



Rubber Hand Sanding Blocks

- Resilient rubber blocks that conform well to mild contours and flat surfaces

DESCRIPTION	STD. PKG.	PART NO.
2-3/4 x 5	5	07660701889

AVAILABILITY
PSA/
HOOK & LOOP
PAPER ROLLS



TIER:	BEST	BEST	BEST	BETTER	BETTER	BETTER	BETTER
BRAND:	Norton	Norton	Norton	Norton	Norton	Norton	Norton
TRADENAME:	A975 NO-FIL	A975 NO-FIL	A975 NO-FIL	A275 NO-FIL	A275 NO-FIL	A275 NO-FIL	A275 NO-FIL
ABRASIVE:	C/A	C/A	C/A	A/O	A/O	A/O	A/O
BACKING WEIGHT:	C-Wt.	C-Wt.	B-Wt.	B-Wt.	B-Wt.	B-Wt.	B-Wt.
BACKING ATTACHMENT:	PSA	PSA	PSA	PSA	PSA	PSA	PSA
OTHER:	P-Graded	P-Graded	P-Graded	P-Graded	P-Graded	P-Graded	P-Graded
SIZE:	2-3/4" x 25yd	2-3/4" x 30yd	2-3/4" x 45yd	2-3/4" x 25yd	2-3/4" x 30yd	2-3/4" x 45yd	4-1/2" x 10 yd

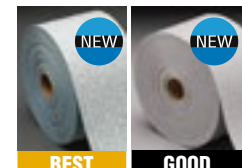

TIER:	BEST	GOOD
BRAND:	Norton	Merit
TRADENAME:	A975 NO-FIL	PB273 NO-LOAD
ABRASIVE:	C/A	A/O
BACKING WEIGHT:	B-Wt.	B-Wt.
BACKING ATTACHMENT:	Hook & Loop*	Hook & Loop•
OTHER:	P-Graded	P-Graded
SIZE:	2-3/4" x 13 yd	3" x 12 yd

GRIT	MIN./STD. PKG.	PART NO.	PART NO.	PART NO.	PART NO.	PART NO.	PART NO.	PART NO.	MIN/STD PKG	PART NO.	PART NO.
80	1/5	66261149566			66261131691			66261131697	1/4	63642506261	66623345609
100							66261131690	66261131696			
120			66261149564				66261131689	66261131695		63642506259	66623334493
150				66261149563				66261131688		63642506258	66623334494
180				66261149562				66261131687		63642506257	66623334495
220				66261149561				66261131686		63642506256	66623345611
240								66261131685			
320				66261149558				66261131683		63642506255	66623335601
400				66261149557				66261131681		66623329518	66623345612
500										66623329547	
600								66261131679		66623329548	

* THE 2-3/4" WIDE HOOK AND LOOP PAPER ROLL IS PERFORATED AT 2-3/4" WHICH ALLOWS USE ON ALL STANDARD LENGTHS OF HAND BLOCKS AND FILE BOARDS.
 • THE 3" WIDE HOOK AND LOOP PAPER ROLL IS PERFORATED AT 4-1/4" TO ALLOW FOR USE ON DYNABRADE'S "DYNABUG II®" TOOL.

PSA Roll Accessories



- PSA Roll Dispenser**
- Heavy-duty wire dispenser has a vinyl coating to protect the work surface
 - Accommodates two 2-3/4" PSA rolls; stackable for multi-grit operations. Attach to wall or mount on cabinet

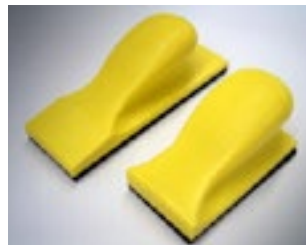

- PSA/Hook & Loop Sanding Blocks**
- Ergonomically-shaped flexible foam blocks used with 2-3/4" rolls, fit comfortably in your hand
 - Firm block produces a true flat surface
 - The soft block is designed for flat surfaces and contours

DESCRIPTION	STD. PKG.	PART NO.
PSA Roll Dispenser	1	63642542773

SIZE	DESCRIPTION	STD. PKG.	BACKING ATTACHMENT:	
			PSA	HOOK & LOOP
			PART NO.	PART NO.
2-3/4 x 5	Soft	5	63642542090	63642542092
2-3/4 x 5	Firm	5	63642542091	63642542093
2-3/4 x 7-3/4	Soft	5		63642542095
2-3/4 x 7-3/4	Firm	5	63642542094	



Rotolo Foam Sanding Pads

APPLICATION/GRIT RECOMMENDATION GUIDE

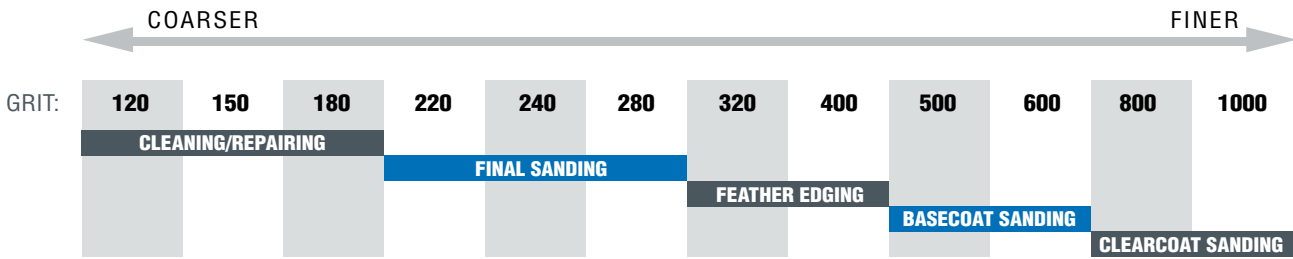

FEATURED PRODUCTS



NO-FIL NORTON ADALOX A275ROTOLO FOAM ROLLS

THE BETTER CHOICE FOR FINE SANDING FLAT AND CURVED SURFACES

FEATURES

- A275 (premium P-graded, aluminum oxide grain with No-Fil coating) on Rotolo foam backing
- 4-1/2" wide x 82' long roll perforated every 5-1/2"
- Convenient dispensing box

BENEFITS

- Perfect for hand sanding without leaving finger marks
- Provides outstanding finish on wood, metal, and composites, and primers, sealers and top coats
- Fast cut and long life without loading
- Compatible with all coatings
- 50% – 60% improvement in tear strength
- Standard 1/4 sheet size for hand or machine sanding; 178 sheets per roll
- Protects A275 Rotolo foam from damage

AVAILABILITY

TIER:	BETTER
BRAND:	Norton
TRADENAME:	ROTOLO
ABRASIVE:	Aluminum Oxide

SIZE (W x L)	GRIT SIZE	STD. PKG.	PART NO.
4-1/2" x 82'	P120	2	63642535316
	P150	2	63642557584
	P180	2	63642557599
	P220	2	63642557600
	P240	2	63642557602
	P280	2	63642557604
	P320	2	63642557606
	P400	2	63642557608
	P500	2	63642557611
	P600	2	63642557612
	P800	2	63642557613
	P1000	2	63642557616





CATEGORY DEFINITION

Engineered for flexibility and fast cutting, cloth sheets and rolls have a longer life than paper. They tear cleanly and straight without shedding and are packed in a protective dispenser to eliminate waste and damage.

- CATEGORIES:** All Purpose Aluminum Oxide Cloth Sheets and Rolls (Metalite), Emery Cloth Sheets, Silicon Carbide Screen Sheets and Rolls
- APPLICATIONS:** Scouring and light deburring, scale and rust removal, blending and fine sanding, polishing lathe turnings, rolls and cylinders, and blending machine tool marks
- SIZE RANGE:** Sheets: 9" x 11"
Rolls: 1" x 10 yds., 1-1/2" – 2" x 25 yds., 1" – 4" x 50 yds.
- GRIT RANGE:** 40 – 600, extra coarse, coarse, medium, fine
- ABRASIVE GRAIN:** Aluminum Oxide, Silicon Carbide, Emery

CROSS REFERENCE GUIDE

NORTON	GOOD			
	Metalite K224/K225	Metalite K227	Emery K622	Screen-Bak Q421
3M	311T Three-M-lte BG 211K Electrocut	211K Three-M-lte 311K Three-M-lte	011k Crystal Bay	481Q
Hermes	RB317LX	RB232J	–	–
Klingspor	CS310X	KL361	KL371	–
Sait	DA-F	EA-F	–	Saitscreen
SIA	–	2947J	C680J	–
VSM	KK504X	KK504J, KK504X	–	–

APPLICATION/STARTING RECOMMENDATION GUIDE

Durability/Stock Removal	Conformability	Slower Cut	Waterproof
Fast Cut	Excellent Finish	Fine Finish	Load Resistant
Metalite K224/K225	Metalite K227	Emery K622	Screen-Bak Durite Q421

AVAILABILITY CLOTH SHEETS

SIZE	GRIT	MIN./STD. PKG.	GOOD			MIN./STD. PKG.	PART NO.		
			TIER:	BRAND:	TRADENAME:				
9 x 11	40	25/125	GOOD	Norton	METALITE K224/K225	25/125	66261058713		
	50	25/125	GOOD	Norton	METALITE K227				
	60	25/125	GOOD	Norton	EMERY K622				
	80	25/125	GOOD	Norton	SCREEN-BAK Q421				
	100	50/250			Silicon Carbide			66261100960	
	120	50/250			P-Graded			66261100955	
	150	50/250			P-Graded/Waterproof			66261100950	
	180	50/250						66261100945	
	220	50/250						66261100940	
	240	50/250						66261100935	
	280	50/250							
	320	50/250							
	400	50/250						25/125	66261100920
	500	50/250						25/125	66261100915
	600	50/250							
	Extra Coarse	25/125						66261101255	
	Coarse	25/125						07660701307	
	Medium	50/250						07660701309	
	Fine	50/250						07660701308	



**AVAILABILITY
CLOTH ROLLS**

GRIT	MIN./STD. PKG.	PART NO.	PART NO.	PART NO.	PART NO.	PART NO.
40	1/5		66261058716	66261058715	66261058714	
50			66261127728	66261127730	66261127732	
60			66261127729	66261127731	66261127733	
80		66261134298	66261126276	66261126288	66261126299	
100		66261134299	66261126275	66261126287	66261126298	
120		66261134300	66261126274	66261126286	66261126297	66261127285
150		66261134301	66261126273	66261126285	66261126296	
180		66261134302	66261126272	66261126284	66261126295	
220			66261126271	66261126283	66261126294	
240		66261134303	66261126270	66261126282	66261126293	
280			66261126269	66261126281	66261126292	
320		66261134304	66261126268	66261126280	66261126291	
400			66261126267	66261126279	66261126290	
600			66261126266	66261126278	66261126289	

TIER: **GOOD**

BRAND: Norton

TRADENAME: **K224/K225**

ABRASIVE: Aluminum Oxide

SIZE: 1" x 10 yds

OTHER: P-Graded

**AVAILABILITY
CLOTH ROLLS**

GRIT	MIN./STD. PKG.	PART NO.	PART NO.	PART NO.	PART NO.	PART NO.
80	1/5	66261109180	66261109255	66261109335	66261107275*	
100		66261058721	66261058719	66261109330		
120		66261109170	66261109245	66261109325	66261107270*	66261149811*
150		66261058720	66261058717	66261109320		
180		66261109160	66261109235	66261109315	66261107265*	
280		66261109150	66261109225	66261109305		
320		66261109140	66261109215	66261109295		

TIER: **GOOD**

BRAND: Norton

TRADENAME: **K227**

ABRASIVE: Aluminum Oxide

SIZE: 1" x 50 yds

OTHER: P-Graded

TIER: **GOOD**

BRAND: Norton

TRADENAME: **Q421**

ABRASIVE: Silicon Carbide

SIZE: 1-1/2" x 25 yds

OTHER: P-Graded Waterproof

* PACKAGING STANDARDS: MIN. /STD. PKG.: (Q421) 1/10

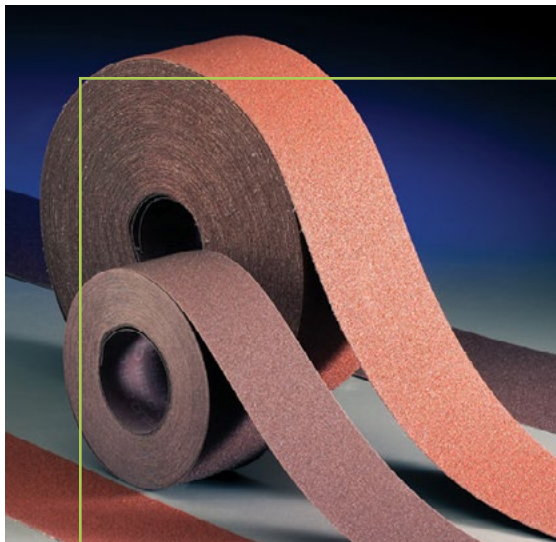

FastTrack Service – Cloth Rolls

FastTrack delivery is available on made-to-order aluminum oxide R228 and K225 50-yard rolls with 5-day lead-time. Contact your local distributor for details and prices.

Availability

- Width: 2" – 12"
- Length: 50 yards

FastTrack Roll Quantity Availability

WIDTH	MINIMUM QTY.	MAXIMUM QTY.
2" to 9"	5 Rolls	10
9" to 11"	4 Rolls	8
11" to 12"	3 Rolls	6

LENGTH = 50 YARDS FOR ALL FASTTRACK ROLLS

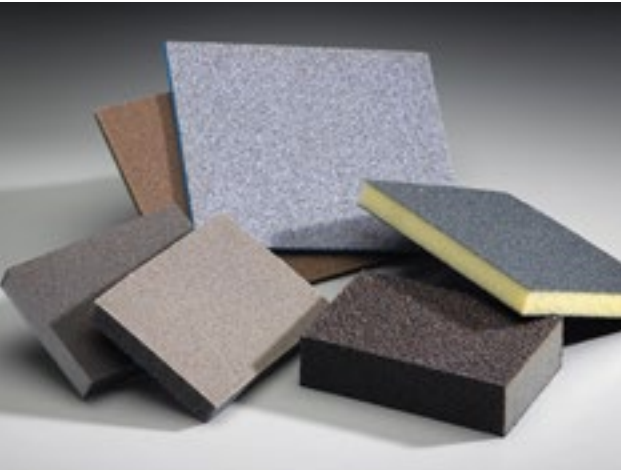

CATEGORY DEFINITION

Flexible, abrasive sanding sponges for a wide variety of curved, contoured or flat surface applications on wood, metal, paint, plastic, ceramics and drywall.

APPLICATIONS: Light stock removal, sanding sealer and wash-coats, touch-up or repair of primer, sanding contours and intricate shapes, and finishing

- BENEFITS:**
- Can be used wet or dry
 - Clog resistant, washable, reusable
 - Easy to use, can be folded without cracking
 - Conformable
 - Generate a consistent surface finish

WHY CHOOSE ABRASIVE SPONGES VERSUS CONVENTIONAL SHEETS?



Eliminate Clogging

- The combination of flexible foam backing material and abrasive grit adhesion continually releases sanded material
- Any clogging can be washed out

Pressure Control

- Foam backing allows optimum pressure distribution to prevent sanding through surfaces
- Pressure spots are eliminated providing even surface pattern

Adapt to Contours

- Flexible foam allows adaptability to contours, shapes or areas of limited access
- No folding or buckling results in an even pattern without scratching

SURFACE FINISHING CHART – CONTOUR SPONGES VERSUS SHEETS

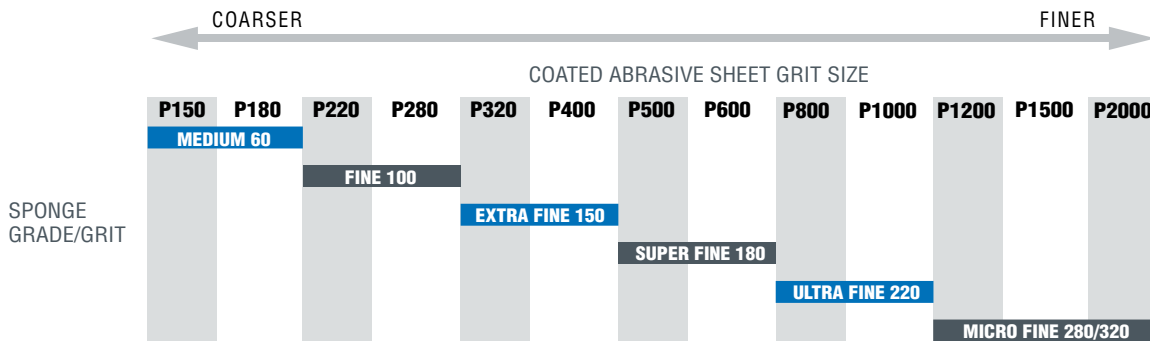

SURFACE FINISHING CHART – SPONGE PADS VERSUS SHEETS

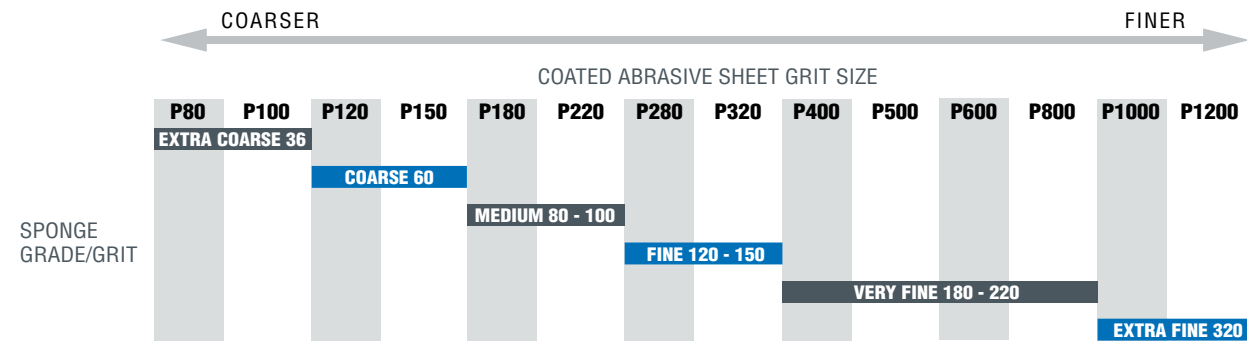

CROSS REFERENCE GUIDE

	BETTER	GOOD	GOOD	GOOD	GOOD	GOOD
	Soft Touch	Contour	Small Area	Profile	Sealer Sanding	Flexible
NORTON	Softback	Contour	Full Size	High Flexibility	Woodworking	Pro Pads
3M	Single Side	–	Four Sided	–	Two Sided	–
Hermes	–	–	–	–	Foam Sanding Pad	–
Klingspor	–	–	–	–	Standard Pad	–
SIA	Flat Pad	–	Standard Block	–	–	–



FEATURED PRODUCTS AND AVAILABILITY

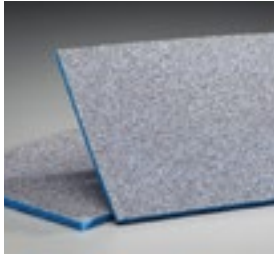

BETTER SOFTTOUCH CONTOUR SPONGES – COATED 1 SIDE

- Superior flexibility; for hand-sanding or finishing flat, curved, contoured and hard-to-reach areas on wood, metal, composites, paint and solid surfaces
- Premium foam substrate provides for an extremely smooth and uniform sanded surface

SIZE (W x L x T)	GRIT	STD. PKG.	PART NO.
4-1/2 x 5-1/2 x 3/16	60 Medium	80	07660703074
	100 Fine	80	07660703075
	180 Super Fine	80	07660703076
	220 Ultra Fine	80	07660703077
	280 Micro Fine	80	07660703078



GOOD CONTOUR SPONGES – COATED 1 SIDE

- Thin, flexible; good for sanding small diameters and contours such as ceramics, spindles, turnings and railings

SIZE (W x L x T)	GRIT	STD. PKG.	PART NO.
4-1/2 x 5-1/2 x 3/16	100 Fine	100	07660702257
	150 Extra Fine	100	07660702256
	220 Ultra Fine	100	07660702255

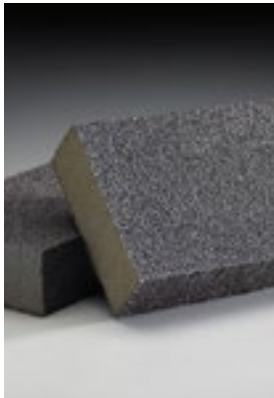

GOOD SMALL AREA GENERAL PURPOSE SPONGES – COATED 4 SIDES

- Good for a wide variety of materials and sanding applications where moderate flexibility is needed
- Medium to firm density open cell polyurethane foam provides uniform support and moderately aggressive cutting action while generating a smooth surface

SIZE (W x L x T)	GRIT	STD. PKG.	PART NO.	STD. PKG.	PART NO.
4 x 2-3/4 x 1	36/80 Ex. Coarse/Med	24	07660749505	250	07660704735
	80/80 Med/Med	24	07660749507	250	07660701875
	80/120 Med/Fine	24	07660749504	250	07660702600
	120/120 Fine/Fine	24	07660749506	–	–



GOOD PROFILE SPONGES – COATED 3 SIDES

- Good for corners and flat surfaces on wood, metal, plastic and paint
- Ideal for cabinet sanding of raised profile doors

SIZE (W x L x T)	GRIT	STD. PKG.	PART NO.
4 x 2-3/4 x 1/2	60 Coarse	500	63642536314
	100 Medium	500	63642536313

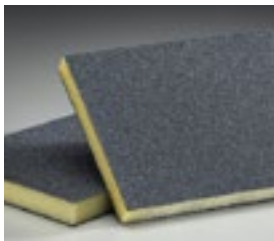

GOOD SEALER SANDING SPONGES – COATED 2 SIDES

- Very flexible; silicon carbide abrasive for sanding primers, sealers and between coats on furniture and cabinets

SIZE (W x L x T)	GRIT	STD. PKG.	PART NO.
4-3/4 x 3-3/4 x 1/2	60 Coarse	250	63642536334
	80 Medium	250	63642502538
	100 Medium	250	63642552870
	150 Fine	250	63642552869
	220 Very Fine	250	63642552868



GOOD FLEXIBLE ABRASIVE SPONGES – COATED 1 SIDE

- Ideal for final sanding of surfaces, primer sanding and between coats sanding
- Best initial price point for abrasive sponges

SIZE (W x L x T)	GRIT	STD. PKG.	PART NO.	STD. PKG.	PART NO.
3 x 4 x 1/2	60 Coarse	48	07660704068	108	07660701110
	80 Medium	48	07660704067	108	07660704070
	100 Medium	48	07660704066	108	07660700950
	150 Fine	48	07660704065	108	07660700949
	220 Very Fine	–	–	108	07660704069





CATEGORY DEFINITION

Portable file belt sanders have replaced tedious hand filing and sanding. First introduced in pneumatic, they are now available in electric. Increasingly, tool manufacturers are introducing additional fixtures for an increasing number of applications. The belts listed are popular stock sizes, but additional sizes, specifications, backing materials, and edge scallops are available made-to-order.

- APPLICATIONS:** Light weld removal and blending, shape and contour sanding, surface preparation prior to coating and plating, removing cutting tool marks from molds and dies, general clean-up and finishing
- SIZE RANGE:** 1/8" to 1" wide, 12" to 30" long
- GRIT RANGE:** 40 – 120
- ABRASIVE GRAIN:** Ceramic Alumina, Zirconia Alumina, Aluminum Oxide

CROSS REFERENCE GUIDE

	BEST Blaze R980P	BEST Norton SG R981	BETTER BlueFire R887P/R823P	GOOD Metalite R283
NORTON				
3M	977F	963G, 967F	577F, 777F	241E
Hermes	CR456	–	RB486 44 Z	RB317J, RB316EJ RB303 Flex
Klingspor	CS610YY	–	CS411YX, CS 409Y	CS310XF
SIA	–	–	–	933A, 936A
VSM	SK840X, SK750X	–	KK715X	KK711T, KK511J

MATERIAL-TO-PRODUCT RECOMMENDATION GUIDE

	HEAVY-DUTY		GENERAL-DUTY
	BEST Highest Productivity – Lowest Total Cost.	BETTER Excellent Blend of Performance & Price	GOOD Consistent Performance – Low Initial Price
Carbon Steel	Norton Blaze R980P	Norton BlueFire R887P/R823P	Norton Metalite R283
Stainless Steel / Alloys	Norton Blaze R980P	Norton BlueFire R887P/R823P	Norton Metalite R283
Cast Iron	Norton Blaze R980P	Norton BlueFire R887P/R823P	Norton Metalite R283
Brass/Bronze	–	Norton BlueFire R887P/R823P	Norton Metalite R283
Aluminum	–	Norton BlueFire R887P/R823P	Norton Metalite R283

FEATURED PRODUCTS



NORTON BLAZE R980P

BEST FOR STAINLESS, COBALT, CHROME, INCONEL, TITANIUM, MILD AND CARBON STEEL

FEATURES

- Next-generation cooler cutting Norton SG ceramic alumina grain
- Y-wt. polyester waterproof cloth backing
- Improved resin bond system
- Advanced “supersize” grinding lubricant

BENEFITS

- Lasts 50% to 200% longer on mild and carbon steel, stainless, cobalt, chrome, Inconel and titanium
- Cuts 20% faster than the current generation of ceramic alumina grinding belts
- Better metal integrity
- Edge-fray resistance
- Improved body-retention during use for more consistent grinding throughout belt life
- Significantly improved belt life due to exceptional grain adhesion
- Cooler cutting during the life of the belt
- Improved part finish and integrity



FEATURED PRODUCTS



NORTON BLUEFIRE R887P/R823P
THE BETTER CHOICE FOR STAINLESS AND CARBON STEEL

FEATURES

- New high performance, self-sharpening zirconia alumina
- New high performance resin bond
- Strong Y-wt. polyester backing - R887P
- Flexible X-wt. polyester backing - R823P

BENEFITS

- 15% improvement in cut rate and life
- Strong grain adhesion, longer life
- For heavy-duty stock removal applications
- For moderate- to light-pressure applications

AVAILABILITY



TIER:	BEST	BEST	BETTER	GOOD	GOOD
BRAND:	Norton	Norton	Norton	Norton	Norton
TRADENAME:	BLAZE R980P	SG R981	BLUEFIRE R887P/R823P	METALITE R283	NEON R766
ABRASIVE:	Ceramic Alumina	Ceramic Alumina	Zirconia Alumina	Aluminum Oxide	Premium A/O Blend
BACKING:	Y-wt. Polyester	Y-wt. Polyester	Y-wt./X-wt. Polyester	X-wt. Rayon	Y-wt. Polyester
OTHER:	Supersize				

SIZE (W x L)	GRIT	STD. PKG.	PART NO.	PART NO.	PART NO.	PART NO.	PART NO.
12" Belts							
1/8 x 12	40	50	66254491518	66254491521	66254492520	66254491536	66623390000
	60	50	66254405345	66254491522	66261093029		66623390001
	80	50	66261089479	66254491523	66261093030	66254491537	66623390002
	120	50	66254491519	66254491524	66254491533	66254491538	
1/4 x 12	40	50	66254491520	66254491525	66254492521	66254491539	66623390003
	60	50	66261196480	78072760823	78072758896		66623390004
	80	50	66261063617	66254491526	78072782621	78072766143	66623390005
	120	50	66261063632	66254491527	78072782622	78172763175	
1/2 x 12	40	50	69957398018	66254491528	66254492522	78072727557	66623390006
	50	50	66261043759	78072718700	66254492523	66254491540	66623390007
	60	50	69957398019	78072718701	78072728745	78072727555	66623390008
	80	50	69957398020	78072718702	78072728744	78072727554	66623390009
	100	50	66261081180	66254491529	66254491534	78072727553	
	120	50	66261042909	78072700518	78072728742	78072727552	
1 x 12	60	50	66261063641	78072761985	78072753073	78072773813	66623390010
13" Belts							
3/8 x 13	60	50	69957345359	78072745459	78072740295	78072732112	66623390011
	80	50	69957392150	78072774916	78072736062	78072771323	66623390012
18" Belts							
1/8 x 18	40	50	66254475211	66254491530	66254492524	66254491541	66623390013
	60	50	66261080010	78072781570	66254491535		66623390014
	80	50	66261089120	78072789083	78072760595	63642594761	66623390015
	120	50	66254475215	78072789084	63642595221	66254491542	
1/4 x 18	40	50	66261027923	66261198953	66254492525	66254491543	66623390016
	60	50	69957347249	78072774684	78072743583	78072771000	66623390017
	80	50	69957346155	78072703284	78072753075	78072773921	66623390018
	120	50	66261085071	78072785655	78072773764		
1/2 x 18	40	50	69957398021	78072766018	66254444193	78072727561	66623390019
	60	50	69957398022	78072718704	78072728569	78072727560	66623390020
	80	50	69957398023	78072718705	78072728568	78072727559	66623390021
	120	50	66261041384	78072718706	78072728567	78072727558	
3/4 x 18	40	50	69957398027	78072762476	66254492526	78072781797	66623390022
	60	50	69957398028	78072745691	78072709590	78072739966	66623390023
	80	50	69957398029	78072756309	78072758953	78072732289	66623390024
20-1/2" Belts							
3/4 x 20-1/2	40	50	69957398030	78072714398	66254457869	78072727573	66623390025
	50	50	69957344982	78072718714	66254492527	66254491544	66623390026
	60	50	69957398031	78072718715	78072728560	78072727571	66623390027
	80	50	69957398032	78072718716	78072728559	78072727570	66623390028
	100	50	66261055516	78072771151	66261038911	78072727569	
	120	50	66261044755	78072727380	78072728557	78072727575	



AVAILABILITY



TIER:	BEST	BEST	BETTER	GOOD	GOOD
BRAND:	Norton	Norton	Norton	Norton	Norton
TRADENAME:	BLAZE R980P	SG R981	BLUEFIRE R887P/R823P	METALITE R283	NEON R766
ABRASIVE:	Ceramic Alumina	Ceramic Alumina	Zirconia Alumina	Aluminum Oxide	Premium A/O Blend
BACKING:	Y-wt. Polyester	Y-wt. Polyester	Y-wt./X-wt. Polyester	X-wt. Rayon	Y-wt. Polyester
OTHER:	Supersize				

SIZE (W x L)	GRIT	STD. PKG.	PART NO.	PART NO.	PART NO.	PART NO.	PART NO.
24" Belts							
1/4 x 24	40	50	66261198631	78072747823	66254473499	66254401929	66623390029
	60	50	69957345451	78072756534	78072728552	78072727548	66623390030
	80	50	63642596940	78072718340	78072767713	78072791441	66623390031
	120	50	66261080367	78072770718	78072728550	78072722137	
1/2 x 24	40	50	69957398024	78072760092	66254492528	78072727568	66623390032
	50	50	66261043757	78072718707	66254452237	78072727567	66623346910
	60	50	69957398025	78072718708	78072728564	78072727566	66623390033
	80	50	69957398026	78072718709	78072728566	78072727565	66623390034
	100	50	66261042203	78072745021	78072753076	66254491545	
1 x 24	40	50	69957350019	66254491531	66254492529	66254491546	66623390035
	50	50	69957344889	78072710374	66254492530	66254491547	66623390036
	60	50	69957353375	78072737318	78072798720	66254491548	66623390037
	80	50	69957345419	78072772209	78072776498	66261085068	66623334206
	120	50	66261085067	66254491532	78072730029	66261085069	
30" Belts							
1 x 30	40	50	66261053470	78072765229	66254478257	66261189958	66623390038
	60	50	69957345985	66261198336	78072728583	66254491549	66623390039
	80	50	69957346105	78072764439	78072728582	78072727579	66623390040
	120	50	66261193676	78072781197	78072766992	78072727577	

ADDITIONAL SIZES, GRITS AND SCALLOPED EDGE BELTS ARE AVAILABLE MTO (MADE-TO-ORDER). PLEASE CONTACT YOUR LOCAL NORTON DISTRIBUTOR TO CHECK AVAILABILITY.
 40 AND 50 GRIT NORTON BELTS ARE FURNISHED IN NORTON BLUEFIRE R887 (Y-WT POLYESTER)
 JOINTS AND FLEXES – ALL BELTS ARE PG JOINTED; A BUTT JOINT JOINED WITH FLEXIBLE TAPE FOR CONTOUR GRINDING



Rapid Solutions for Surface Conditioning

2X-3X the Life of Competitive Non-Woven Belts

Fully stocked in all industry-standard sizes and colors for use of use and conversion. Norton's proprietary new coating method provides a thick layer of grain throughout the product for extended life without shedding off the top. The new resin system will not load on aluminum or soft metals and resists smearing, even on high nickel content alloys. Now the market's leading product for most consistent cutting and finishing capabilities with a reduction in process and steps. Norton innovation hard at work. See page 162 for availability.



CATEGORY DEFINITION

Portable belts are ideal for all your metal and woodworking applications. Choose 36 – 50 grits for rough/heavy-duty applications, 60 – 100 for intermediate, and 100 – 220 for finishing/polishing applications. Stock is available for wood applications and FastTrack service is used for all other applications.

- APPLICATIONS:** Grinding and finishing all metals, blending welds, sanding and finishing wood, glass seaming, and polishing
- SIZE RANGE:** 3" to 4" wide, 15-1/2" to 24" long
- GRIT RANGE:** 36 – 220
- ABRASIVE GRAIN:** Ceramic Alumina, Zirconia Alumina, Aluminum Oxide

CROSS REFERENCE GUIDE

	BEST SG R981	BETTER BlueFire R831	GOOD Metalite R215/R228
NORTON			
3M	977F, 967F, 963G	777F, 577F	241D, 340D
Hermes	RB346MX	RB484Z	RB316XOP
Klingspor	CS610YY	CS411Y	CS311YX, CS310X, LS309XH
Sait	–	ZH	AOX, IAX
SIA	–	–	2903XO, 2905X, 2920X
VSM	SK855X	ZK713X	KK511X, KK711X, KK504X

MATERIAL-TO-PRODUCT RECOMMENDATION GUIDE

	HEAVY-DUTY		GENERAL-DUTY
	BEST Highest Productivity – Lowest Total Cost	BETTER Excellent Blend of Performance & Price	GOOD Consistent Performance – Low Initial Price
Wood	–	Norton NorZon R831	Norton Metalite R215
Stainless Steel / Carbon Steel	Norton SG R981	Norton NorZon R831	Norton Metalite R228
Brass / Bronze / Aluminum	–	Norton NorZon R831	Norton Metalite R215

FEATURED PRODUCTS



NORTON SG R981

EXCEPTIONAL PERFORMANCE, ESPECIALLY ON HARD-TO-GRIND ALLOYS

FEATURES

- Norton SG ceramic abrasive
- Grinding-aid enhanced
- Strong Y-wt polyester, waterproof cloth backing

BENEFITS

- Exceptional life and value, especially on hard-to-grind alloys
- Longer life, cooler cut
- Improved grain adhesion, reduced edge-fray and better body retention, result in longer life and product consistency



NORTON BLUEFIRE R831

THE BETTER CHOICE FOR STAINLESS STEEL

FEATURES

- Premium, self-sharpening zirconia alumina
- Reversible butt splice
- Open-coat design, strong Y-wt. cotton backing

BENEFITS

- Aggressive abrasive, rapid cut rate, long life
- Use in either direction for longer life
- Reduced loading, extended life



Portable Belts for Belt Sanders

Portable electric belt sanders are used on wood, metal, and other materials, for applications ranging from stock removal to finishing. They consist of an electrical motor that turns a pair of drums on which an abrasive belt is mounted.

Belt sanders can be either hand-held, where the sander is moved over the material, or stationary (fixed), where the material is brought to the sanding belt.



AVAILABILITY



TIER:	BETTER	GOOD	GOOD
BRAND:	Norton	Norton	Norton
TRADENAME:	BLUEFIRE R831	METALITE R215	METALITE R228
ABRASIVE:	Zirconia Alumina	Aluminum Oxide	Aluminum Oxide
JOINT:	Plyweld	Plyweld	Plyweld
GRAIN COATING:	Open Coat	Open Coat	Open Coat
OTHER:			UPC Bar Coded

SIZE (W x L)	GRIT	MIN./STD. PKG.	PART NO.	PART NO.	MIN./STD. PKG.	PART NO.
3 x 18	36	5/25			5/5	78072780447
	50		07660749259	07660700964	10/10	78072727994
	80		07660749258	07660700968		78072727993
	120		07660749256	07660700969		78072727992
3 x 21	36	5/25	07660749266	07660701741	10/10	
	40					78072727927
	50		07660749265	07660701740		78072727926
	60					78072727925
	80		07660749264	07660702064		78072727924
	100		07660749263			78072727923
	120		07660749262	07660702062		78072727922
	220			07660705287		
3 x 24	36	5/25	07660749272	07660701743	5/5	78072781847
	40				10/10	78072727937
	50		07660749271	07660701742		78072727936
	60					78072727935
	80		07660749270	07660702067		78072727934
	100		07660749269	07660702066		78072727933
4 x 24	120	5/25	07660749268	07660702065		78072727932
	36		07660749278	07660701745	5/5	78072780438
	40				10/10	78072727947
	50		07660749277	07660701744		78072727946
	60					78072727945
	80		07660749276	07660702069		78072727944
	100		07660749275			78072727943
	120		07660749274	07660702068		78072727942
180		07660705285				

Portable Belts for Pneumatic In-Line Drum Sanders

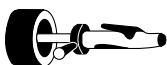

AVAILABILITY



TIER:	BEST	BETTER	GOOD
BRAND:	Norton	Norton	Norton
TRADENAME:	SG R981	BLUEFIRE R823P	METALITE R215 / R228
ABRASIVE:	Ceramic Alumina	Zirconia Alumina	Aluminum Oxide
JOINT:	Plyweld	Plyweld	Plyweld
GRAIN COATING:	Close Coat/Supersize	Close Coat	Open Coat

SIZE (W x L)	GRIT	MIN./STD. PKG.	PART NO.	PART NO.	PART NO.
3-1/2 x 15-1/2	36	10/10	78072700783		78072721997
	60		78072718750		78072722000
	80		78072718751	78072753074	78072721995
	120		78072718753		



CATEGORY DEFINITION

A wide selection of sizes and grits for most dimensioning, intermediate grinding and polishing applications.

APPLICATIONS: Benchstand and Backstand Belts: grinding and deburring of all metals, heavy stock removal, blending, dimensioning and shaping, polishing.

Centerless, Conveyor and Platen Belts: intermediate grinding stainless and carbon, moderate-pressure applications, dimensioning and finishing.

SIZE RANGE: 1" to 10" wide, 36" to 132" long

GRIT RANGE: 36 – 320

ABRASIVE GRAIN: Ceramic Alumina, Zirconia Alumina, Aluminum Oxide

CROSS REFERENCE GUIDE

	BEST Blaze R980P	BEST SG R981	BETTER BlueFire R887P	BETTER BlueFire R821P	BETTER BlueFire R823P	BETTER BlueFire R884P	GOOD Metalite R228
NORTON 3M	987F1, 977F, 777F, 967F, 963G, 963H	987F1, 977F, 777F, 967F, 963G, 963H	577F, 567G, 777F 977F	561D	561F Y, 551E XE 741A, 741E, 761D	561D, 561F, 563F 741A, 741E, 761D 761F	240DZ OPK, 270DZ OPK, 241D, 248D, 251D, 341I Imperial, 351D
Hermes	CR456	CR456	RB486X, RB486Y RB426-23MX	–	RB486 X, RB346-23MX, RB426-23MX, RB484TY RB486XF	RB484TY, RB486Y, RB346-23MX, RB426-23MX, RB480-21MX, CB440Y, RB486XY	RB3160P RB317LX RB346MX
Klingspor	CS612YY, CS610YY	CS612YY, CS610YY	CS409Y	CS411Y	CS411X	CS411Y	CS311X, CS310, CS410
SIA	–	–	–	–	–	2800, 2803, 2929	2903X0, 2905X, 2920X
VSM	SK840X, SK750X	SK840X, SK750X	KK815Y, ZK744X	–	KK715X	KK716Y, ZK713X	KK511X, KK711

MATERIAL-TO-PRODUCT RECOMMENDATION GUIDE

	BEST Highest Productivity. Lowest Total Cost.	BETTER Excellent Blend of Performance & Price.	GOOD Consistent Performance. Low Initial Price.
Aluminum	–	Norton BlueFire R884P/R823P	Norton Metalite R228
Cast Iron	Norton Blaze R980P	Norton BlueFire R884P/R823P	Norton Metalite R228
Brass / Bronze	–	Norton BlueFire R884P/R823P	Norton Metalite R228
Die Castings	Norton Blaze R980P	Norton BlueFire R884P/R823P	Norton Metalite R228
Carbon Steel	Norton Blaze R980P	Norton BlueFire R884P/R823P	Norton Metalite R228
Glass / Ceramics	Norton Blaze R980P	Norton BlueFire R821P	Norton Durite R480
Stainless Steel and Alloys	Norton Blaze R980P	Norton BlueFire R884P/R823P Norton BlueFire R887P	Norton Metalite R228
Wood	–	Norton BlueFire R831	Norton Metalite R215

GRIT SELECTION RECOMMENDATION GUIDE

STOCK REMOVAL	INTERMEDIATE	FINISHING
36 – 50 grit	60 – 100 grit	120 – 320 grit



FEATURED PRODUCTS



NORTON BLAZE R980P

BEST FOR MILD AND CARBON STEEL, STAINLESS, COBALT, CHROME, INCONEL, TITANIUM

FEATURES

- Next-generation cooler cutting SG ceramic abrasive grain
- Y-wt polyester waterproof cloth backing
- Improved resin bond system
- Advanced “supersize” grinding lubricant

BENEFITS

- Lasts 50% to 200% longer on mild and carbon steel, stainless, cobalt, chrome, Inconel and titanium
- Cuts 20% faster than the current generation of grinding belts
- Longer belt life
- Better metal integrity
- Greater productivity; lowest total grinding costs
- Edge-fray resistance
- Improved body retention during use for more consistent grinding throughout belt life
- Significantly improved belt life due to better grain adhesion
- Cooler cutting during the life of the belt
- Improved part finish and integrity



NORTON SG R981

EXCEPTIONAL PERFORMANCE, ESPECIALLY ON HARD-TO-GRIND ALLOYS

FEATURES

- Norton SG ceramic abrasive
- Grinding-aid enhanced
- Strong Y-wt polyester, waterproof cloth backing

BENEFITS

- Exceptional life and value, especially on hard-to-grind alloys
- Longer life, cooler cut
- Improved grain adhesion, reduced edge-fray and better body retention, result in longer life and product consistency



IMPROVED

NORTON BLUEFIRE R884P/R823P

BETTER CHOICE FOR HEAVIEST-PRESSURE APPLICATIONS

FEATURES

- Premium self-sharpening zirconia alumina abrasive
- R884P – Durable Y-wt polyester, waterproof cloth backing
- R823P – Strong X-wt polyester backing; waterproof

BENEFITS

- Aggressive, rapid cut rate
- Excellent grain adhesion, reduced edge-fray and better body retention, result in longer life and product consistency
- More flexible than R884P
- Available in finer grit sizes



NORTON NEON R766

THE BETTER CHOICE FOR DIFFICULT-TO-GRIND MATERIALS (ALUMINUM, BRASS, BRONZE, STAINLESS, CARBON STEEL, TITANIUM, ETC.)

FEATURES

- Premium abrasive and aluminum oxide blend
- New resin bond system
- Y-wt. waterproof cotton backing

BENEFITS

- Ideal when purchasing criteria is a good-performing, economically priced, general purpose belt
- Improved edge retention and 30% + improvement in life vs. key competitors
- Withstands light- to moderately-demanding applications
- Extended life on dry grinding applications

TECHtip

TROUBLESHOOTING GUIDE

PROBLEM

- Loading**
- Shedding**

CORRECTION

- Decrease infeed pressure or belt speed
- Reduce applied pressure
- Use a less aggressive contact wheel
- Dress contact wheel if worn or damaged
- Use entire surface of belt
- Reduce belt tension
- Use less aggressive contact wheel
- Check tracking mechanism for belts tracking erratically



1" to 6" wide, 36" to 72" long

AVAILABILITY



TIER:
BRAND:
TRADENAME:
ABRASIVE:
BACKING:

BEST	BETTER	BETTER	GOOD	GOOD
Norton	Norton	Norton	Norton	Norton
BLAZE R980P	BLUEFIRE R821P	BLUEFIRE R823P	NEON R766	METALITE R228
Ceramic Alumina	Zirconia Alumina	Zirconia Alumina	Premium A/O Blend	Aluminum Oxide
Y-wt. Polyester	Y-wt. Cotton	X-wt. Polyester	Y-wt. Polyester	X-wt. Cotton





SIZE (W x L)	GRIT	MIN./STD. PKG.	PART NO.	PART NO.	PART NO.	PART NO.	PART NO.
1 x 42	36	50/200	66254476825				78072791710
	40		69957345887	78072726905		66623390041	78072720910
	50		66254476826	78072726904		66623390042	78072720905
	60		69957345486	78072726903	78072728596	66623334502	78072720900
	80		66261041539	78072726902	78072728594	66623390043	78072720895
	100		66261043462		78072728592		78072720890
	120		66261038660		78072728590		78072720885
	150				78072728588		78072720880
	180				78072728586		78072720875
	220						78072720871
	240						78072720870
	320						78072720865
	1-1/2 x 60		36	10/50	69957345578		
40		63642595003					
50		69957345664	78072726991			66623390044	78072787807
60		69957345631	78072726990			66623390045	
80		69957345579			78072726988	66623390046	78072721040
100					78072765077		69957351736
120		66261056493			78072726984		
180							
220					78072708871		78072756615
2 x 48		24	10/50				
	36	63642592057		78072727103		66623390047	78072721255
	40	69957345193		78072727102		66623390048	78072721250
	50	69957346716		78072727101		66623390049	78072721245
	60	69957344423		78072727100	78072728621	66623390050	78072721240
	80	69957345100		78072727099	78072728619	66623390051	78072721235
	100	66261052522			78072728617		78072721230
	120	66261052520			78072728615		78072721225
	150				78072728613		78072723246
	180				78072728611		78072721223
	220				78072728609		78072763677
	320						78072746387
	2 x 60	24		10/50			
36		69957345196				66623390052	78072701170
40		69957394425	78072727124			66623390053	78072721300
50		69957346149				66623390054	78072762537
60		69957344901	78072727122			66623390055	78072721290
80		63642592574	78072727121			66623390056	78072721285
100		66261052222			66261082976		78072721280
120		66261042738			78072761958		78072721275
150							78072744018
180						78072702695	78072720441
220						78072706282	78072744020
240							78072761862
320							78072702825
2 x 72	24	10/50	66254433969				78072721335
	36		69957345460	78072727147		66623390057	78072721332
	40		69957346729	78072727146		66623390058	78072784894
	50		69957344966	78072727145		66623390059	78072721325
	60		69957345157	78072727144	78072728645	66623390060	78072721320
	80		69957344961	78072727142	78072728643	66623334237	78072723235
	100		66261041897				78072721318
	120		66261044095		78072728639		78072761973
	150						78072718488
	180					78072763853	78072765601
	220					78072728633	78072721308
	320						

CONTINUED...



1" to 6" wide, 36" to 72" long CONTINUED

AVAILABILITY

								
			BEST	BETTER	BETTER	GOOD	GOOD	
TIER:			Norton	Norton	Norton	Norton	Norton	
BRAND:			BLAZE R980P	BLUEFIRE R821P	BLUEFIRE R823P	NEON R766	METALITE R228	
TRADENAME:			Ceramic Alumina	Zirconia Alumina	Zirconia Alumina	Premium A/O Blend	Aluminum Oxide	
ABRASIVE:			Y-wt. Polyester	Y-wt. Cotton	X-wt. Polyester	Y-wt. Polyester	X-wt. Cotton	
BACKING:								
SIZE (W x L)	GRIT	MIN./STD. PKG.	PART NO.	PART NO.	PART NO.	PART NO.	PART NO.	
2-1/2 x 48	36	10/50				66623390061	78072721540	
	40				66623390062			
	50			78072727213		66623390063	78072721530	
	60					66623390064	78072721525	
	80					66623390065	78072721520	
2-1/2 x 60	24	10/50					78072708296	
	36		69957344963	78072727235		66623390066	78072721610	
	40		69957346523	78072727234		66623390067	78072721605	
	50		69957345300	78072727233		66623390068	78072721600	
	60		69957345002	78072727232	78072728692	66623390069	78072721595	
	80		69957346095	78072727231	78072728690	66623390070	78072721590	
	100		66261041380				78072721585	
	120		66261041379		78072728686		78072721580	
	150						78072710118	
	180				78072728682		78072721570	
	220				78072778217		78072721565	
4 x 36	36	10/50				66623390071	78072722110	
	40					66623390072	78072722105	
	50			78072727475		66623390073	78072722100	
	60			78072727474	78072728827	66623390074	78072722095	
	80			78072727473	78072728825	66623390075	78072722090	
	100				78072728823		78072722085	
	120				78072728821		78072722080	
	150						78072722079	
	180						78072722075	
	240						78072722926	
	320						78072722071	
4 x 54	36	10/50	69957346358			66623390076	78072722185	
	40		63642594113			66623390077	78072722180	
	50		66254469595			66623390078	78072722175	
	60		66261063419	78072727518	78072725116	66623390079	78072722170	
	80		69957345139		78072782996	66623390080	78072722165	
	100						78072722160	
	120		66261088705		78072728847		78072722155	
	150				78072789676		78072728381	
	180				66254475370		78072759243	
	220				78072762311		78072762536	
	4 x 60		24	10/50	66254461488			
36		69957345298					78072705189	
40		69957391732					78072744693	
50		69957346715				78072774790	78072761630	
60		63642594485				78072765086	78072762861	
80		69957345099					78072784685	
100							78072763161	
120		66254416188			78072766229		78072787840	
150					66254482609		78072704878	
180					78072709820		78072728393	
220					78072702594		78072790168	
6 x 48	36	10/20	69957345143	78072727698		66623390081	78072722590	
	40			78072727697		66623390082	78072722585	
	50			78072727696		66623390083	78072722580	
	60		20/20	69957344422	78072727695	78072728937	66623390084	
	80				78072727694	78072728935	66623390085	78072722570*
	100				78072728933	78072722565*		
	120				78072728931	78072722560*		
	150				78072770042	78072722555*		
	180					78072722550*		
	220					78072722546*		
	240					78072722545*		
320					78072722543*			

* MIN./STD. PKG. IS 10/50

CONTINUED...



1" to 6" wide, 36" to 72" long CONTINUED

AVAILABILITY

							
			BEST	BETTER	BETTER	GOOD	GOOD
<i>TIER:</i>							
<i>BRAND:</i>			Norton	Norton	Norton	Norton	Norton
<i>TRADENAME:</i>			BLAZE R980P	BLUEFIRE R821P	BLUEFIRE R823P	NEON R766	METALITE R228
<i>ABRASIVE:</i>			Ceramic Alumina	Zirconia Alumina	Zirconia Alumina	Premium A/O Blend	Aluminum Oxide
<i>BACKING:</i>			Y-wt. Polyester	Y-wt. Cotton	X-wt. Polyester	Y-wt. Polyester	X-wt. Cotton
SIZE (W x L)	GRIT	MIN./STD. PKG.	PART NO.	PART NO.	PART NO.	PART NO.	PART NO.
6 x 60	36	10/20				66623343751	78072722680
	40			78072727762		66623390086	78072722679
	60	20/20	69957345149	78072728957		66623390087	78072722665
	80				78072728955	66623390088	78072722660
	100		66254477452				
	120						78072763882

Belt Cleaning Stick

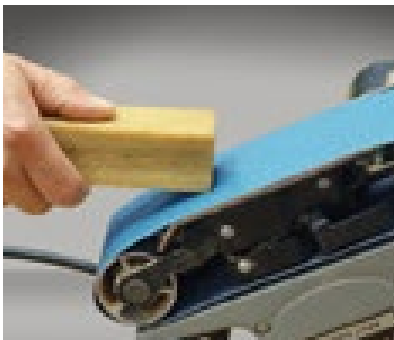

- This solid, rubber cleaning stick is designed to remove wood and other non-metallic materials that build up on belt surface during use.
- Apply it to the face of the belt, while running, to remove unwanted materials and prolong the overall life of the belt up to 10 times.

DESCRIPTION	STD. PKG.	PART NO.
1-3/8 x 1-3/8 x 6	10	07660701717

TECH*tip*

A light bodied grease applied to a benchstand belt surface will reduce loading and greatly enhance the belt life and performance when grinding soft, malleable nonferrous materials such as aluminum, brass, bronze and copper.



2" to 10" wide, over 72" Long

AVAILABILITY



TIER:	BEST	BEST	BETTER	BETTER	GOOD	GOOD
BRAND:	Norton	Norton	Norton	Norton	Norton	Norton
TRADENAME:	BLAZE R980P	SG R981	BLUEFIRE R884P	BLUEFIRE R823P	NEON R766	METALITE R228
ABRASIVE:	Ceramic Alumina	Ceramic Alumina	Zirconia Alumina	Zirconia Alumina	Premium A/O Blend	Aluminum Oxide
BACKING:	Y-wt. Polyester	Y-wt. Polyester	Y-wt. Polyester	X-wt. Polyester	Y-wt. Polyester	X-wt. Cotton

SIZE (W x L)	GRIT	MIN./STD. PKG.	PART NO.	PART NO.	PART NO.	PART NO.	PART NO.	PART NO.
2 x 132	36	10/50		78072753086	78072750016	78072728662	66623347337	
	40			78072750015	66623390089			
	50			78072740771	66623390090			
	60			78072750011	66623390091		78072721445	
	80			78072750008	66623390092		78072721440	
	120							
3 x 132	24	25/50	69957344962	78072750140*	78072728794 78072728792 78072728790 78072728789 78072728785	66623390093	78072721900	
	36		69957344710	78072750138* RR		66623390094	78072721890	
	36			78072750139* L		66623390095	78072721885	
	40		69957344964	78072750135*		66623390097	78072721880	
	50		69957344763				78072721875	
	60		69957344958				78072721870	
	80		69957344764				78072721865	
	100						78072721860	
	120						78072721855	
	150							
	180							
	220							
4 x 132	24	10/50	69957343852	78072750289		66623326093	78072722385 78072722375	
	36			78072739662		66623390098		
	40					66623335394		
	60					66623343488		
	80							
	120							
8 x 107	36	10/20				66623390099	78072722795	
	50					66623390100	78072749887	
	60					66623347341	78072722780	
	80	20/20				66623329182	78072722775	
	80							
	100							
10 x 70-1/2	36	5/10				66623347342	78072722840	
	40					66623347343	78072722835	
	50					66623347344	78072722830	
	60	10/10				66623347345	78072722825	
	60							
	80					66623347346	78072722820	

* MIN./STD. PKG. IS 10/50

FastTrack Belt Service

For non-stock belts, FastTrack Service Centers offer all the benefits of an ISO 9001 quality manufacturer and the advantages of a coated abrasives express belt service. As the industry's leading producer of abrasive material and backings, our FastTrack service offers an extensive range of Norton made-to-order belts including Norton SG ceramic alumina, NorZon zirconia alumina, and versatile aluminum oxide and silicon carbide belts.

Also available in FastTrack are a full line of Merit brand belts. Merit belts have been developed with one simple goal in mind: to provide you economically-priced ceramic alumina, zirconia alumina, and aluminum oxide belts to meet a wide range of applications.

Manufacturing lead-time is two days for narrow belts (1/2" - 12") and three days for wide belts =>14". Please see the FastTrack belt section for complete availability and lead-times.

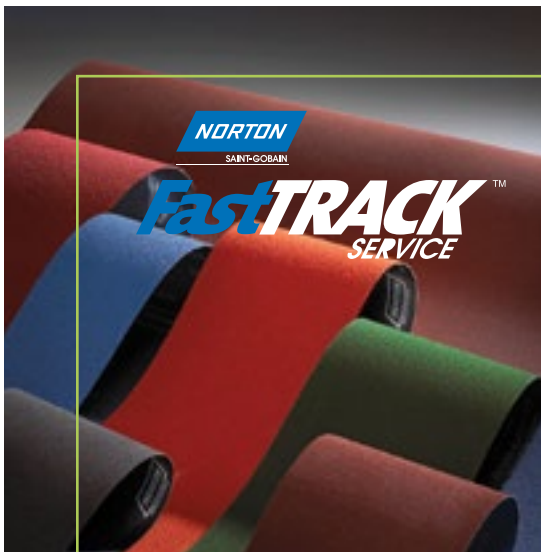

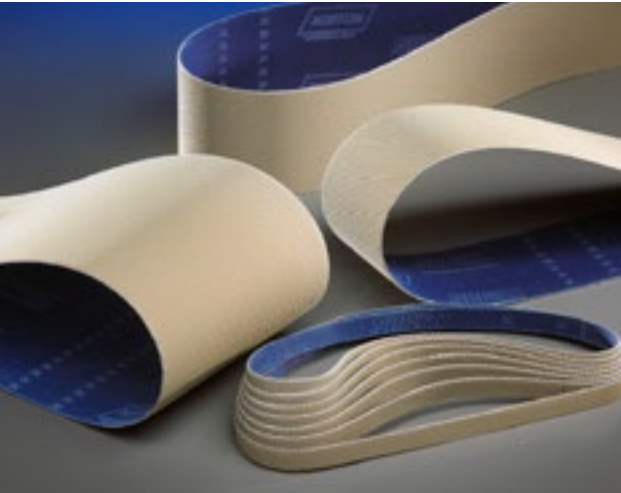

CATEGORY DEFINITION

NORaX belts outlast conventional abrasive belts with 2 - 5 times longer life. Longer life, higher quality finishes, faster cut rates, and the ability to skip finishing steps all help drive down the costs of your finishing processes.

- APPLICATIONS:** Polishing and finishing
- SIZE RANGE:** Stock: 1/8" to 1" wide, 12" to 30" long
- GRIT RANGE:** Stock: X200 and X100
- ABRASIVE GRAIN:** Stock: Ceramic Alumina

FEATURED PRODUCTS



NORaX U936 BELTS

BEST FOR HIGH-PRESSURE PRECISION APPLICATIONS

FEATURES

- Unique, engineered quad surface pattern
- 100% high-performance, micron-graded, cool-cutting Norton SG ceramic alumina abrasive grain
- Improved resin bond system
- Premium, Y-weight polyester waterproof backing
- Fray-resistant backing

BENEFITS

- More abrasive contact area
- Higher cut rates while maintaining more consistent finishes
- Up to more than 2X the life vs. competitive engineered ceramic belts
- Lower specific grinding energy
- Increased durability
- Durable; stands up to high-pressure, coolant applications
- Shred-free

AVAILABILITY

<i>TIER:</i>	BEST	BEST
<i>BRAND:</i>	Norton	Norton
<i>TRADENAME:</i>	NORaX U936	NORaX U936
<i>ABRASIVE:</i>	Ceramic Alumina	Ceramic Alumina
<i>BACKING:</i>	Y-wt. Polyester W/P	Y-wt. Polyester W/P
<i>JOINT/FLEX:</i>	Plyweld, TF	Plyweld, TF
<i>GRIT SIZE:</i>	X200 (80)	X100 (150)

SIZE (W x L)	MIN./ STD. PKG.	PART NO.	PART NO.
1/4 x 12	50	66623300249	66623300261
1/2 x 12	50	66623300245	66623300258
1 x 12	50	66623300240	66623300255
1/4 x 18	50	66623300250	66623300262
1/2 x 18	50	66623300247	66623300259
3/4 x 18	50	66623300253	66623300264
3/4 x 20-1/2	50	66623300254	66623300265
1/4 x 24	50	66623300252	66623300263
1/2 x 24	50	66623300248	66623300260
1 x 24	50	66623300243	66623300256
1 x 30	50	66623300244	66623300257

Call your local Norton distributor or sales representative for information on additional NORaX belt sizes and specifications.

NORaX VERSUS FEPA GRADING

NORaX engineered abrasives perform over a wider range of traditional grit sequences.

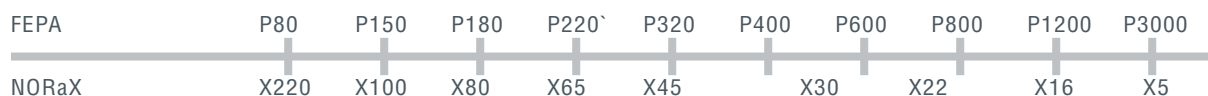



CATEGORY DEFINITION

For many non-stock belts, FastTrack Service Centers offer all the benefits of an ISO 9001 quality manufacturer and the advantages of a coated abrasives express belt service. As the industry leader of abrasive belts, our FastTrack Service offers an extensive range of Norton made-to-order belts including Norton SG ceramic alumina, NorZon zirconia alumina, versatile aluminum oxide, and silicon carbide belts.

Also available in FastTrack are a full line of Merit brand belts. Merit belts have been developed with one simple goal in mind: to provide you economically-priced ceramic alumina, zirconia alumina, and aluminum oxide belts to meet a wide range of applications.

Manufacturing lead-time is two days for narrow belts (1/2" – 12" wide) and three days for wide belts (14 – 52" wide). Please see the FastTrack chart below for complete details on availability and lead-times.

FASTTRACK AVAILABILITY AND LEADTIME INFORMATION

WIDTH*	GRIT SIZE	MINIMUM ORDER QUANTITY	CASE QUANTITY	MAXIMUM ORDER QUANTITY (EQUALS 2 CASES)	CONVERSION LEAD-TIMES
Narrow Belts					
1/2" through 1"	All	50	200	400	2
Over 1" through 5"	All	10	50	100	2
Over 5" through 9"	All	10	20	40	2
Over 9" through 14"	All	10	10	2	2
Wide Belts					
Over 14" through 20"	All	5	10	20	3
Over 20" through 52"	36 & coarser	2	2	4	3
Over 20" through 52"	40-80	3	3	6	3
Over 20" through 52"	100 & finer	5	5	10	3

* FASTTRACK BELT SERVICE APPLIES TO BELTS 25" AND GREATER IN LENGTH

HOW TO PLACE A FASTTRACK BELT ORDER

- Check the FastTrack product availability
- Include a full description of belt: quantity, size, Norton CAP code, and grit size
- Send order electronically, fax, or phone to customer service
- When ordering a belt that does not have an existing part number, please call Customer Service to expedite part number creation





BELT SPECIFICATIONS AND AVAILABILITY

TIER	PRODUCT CAP CODE	SHAPE AVAILABILITY	GRIT SIZE	ABRASIVE GRAIN	BACKING	APPLICATIONS
Metalworking						
Norton						
Best	R980P	Narrow, Wide	24-120	Norton Blaze Ceramic Alumina	Y-wt. Polyester	Latest-generation Norton SG grain, supersized and designed for high-performance grinding on stainless and other alloys
Best	R984	Narrow, Wide	36-120	Norton SG Ceramic Alumina	Y-wt. Polyester	Norton SG grain for medium-pressure grinding and finishing heat-sensitive alloys
Better	R884P	Narrow, Wide	24, 36-80	Norton BlueFire Zirconia Alumina	Y-wt. Polyester	New, significantly improved-performance zirconia alumina grain designed for medium- to high-pressure grinding
Better	R887P	Narrow, Wide	24, 36-120	Norton BlueFire Zirconia Alumina	Y-wt. Polyester	New, significantly improved-performance zirconia alumina grain, supersized and designed for medium- to high-pressure grinding of heat-sensitive alloys
Better	R823P	Narrow, Wide	60-220	Norton BlueFire Zirconia Alumina	X-wt. Polyester	New, significantly improved-performance zirconia alumina grain on lighter backing designed for light to medium grinding
Good	R766	Narrow	P24-80	Aluminum Oxide Blend	J-wt. Cotton	Premium aluminum oxide blend product designed for a variety of applications including soft metals to hard-to-grind stainless and carbon steel
Good	R245	Narrow	P80-P240, P320, P400	Aluminum Oxide	J-wt. Polyester	Aluminum oxide on flexible, lightweight polyester backing for moderate- to light- pressure applications on mild steel
Good	R445	Narrow	60-220	Silicon Carbide	X-wt. Polyester	Sharp, silicon carbide grain on medium polyester backing for grinding very hard materials – glass, stone, solid surface
Good	U243	Narrow, Wide to 12"	X80, X65, X45, X30, X22, X16	Aluminum Oxide	J-wt. Cotton	High-performance, multi-layered NORaX grain on very flexible backing for dry polishing applications
Merit						
Best	SY965	Narrow, Wide	36-120	Ceramic Alumina	Y-wt. Polyester	Ceramic alumina grain supersized for medium-pressure grinding and finishing heat-sensitive alloys
Better	SY603	Narrow, Wide	36-120	Zirconia Alumina	Y-wt. Polyester	New, significantly improved-performance zirconia alumina abrasive with a Y-wt. polyester backing and a grinding aid for weld removal and finishing of hard-to-grind materials
Better	SY695	Narrow, Wide	24-80	Zirconia Alumina	Y-wt. Polyester	New, significantly improved-performance zirconia alumina grain designed for medium- to high-pressure grinding
Better	SX695	Narrow, Wide	60-220	Zirconia Alumina	X-wt. Polyester	New, significantly improved-performance zirconia alumina grain on lighter backing designed for light to medium grinding
Good	SY395	Narrow, Wide	24-120	Ceramic-coated Aluminum Oxide	Y-wt. Polyester	Ceramic-coated aluminum oxide grain provides higher performance than standard aluminum oxide
Good	SX395	Narrow, Wide	P60-P240, P320, P400	Aluminum Oxide	X-wt. Polyester	Higher-performance P-graded aluminum oxide grain and strong polyester backing for mild steel
Good	MX240	Narrow, Wide	P60-P150	Aluminum Oxide	X-wt. Poly/Cotton	P-graded heat-treated aluminum oxide X-wt. cloth with strong, but flexible, cotton/ polyester backing making it an ideal multi-purpose product
Good	KX375	Narrow, Wide	36-240, 320	Aluminum Oxide	X-wt. Cotton	Initial starting specification for all metalworking applications
Good	KF376	Narrow	P80-P320 P400, P600	Aluminum Oxide	J-wt. Cotton	P-graded, heat-treated aluminum oxide with ceramic coating on a very flexible backing for use wherever flexibility and conformability are needed

TIER	PRODUCT CAP CODE	SHAPE AVAILABILITY	GRIT SIZE	ABRASIVE GRAIN	BACKING	APPLICATIONS
Woodworking						
Norton						
Best	R963	Narrow, Wide	24-60, P80 100-150	Norton SG Ceramic Alumina	Y-wt. Polyester	Norton SG ceramic alumina grain with anti-static coating for forest product applications (MDF, particleboard, plywood)
Best	R955	Narrow	P36-P120	Norton SG Red Heat R955	Y-wt. Cotton	100% ceramic alumina abrasive with Y-wt. cloth backing for dimensioning, intermediate sanding of wood
Best	H968	Narrow, Wide	P80-P220	Norton SG Ceramic Alumina	F-wt. Paper	Norton SG ceramic alumina belt for high-performance woodworking applications
Better	R831	Narrow, Wide	24, 36-120	Norton BlueFire Zirconia Alumina	Y-wt. Cotton	BlueFire open-coat product recommended for dry low-pressure applications or where loading is a problem
Good	R215	Narrow, Wide	50-180	Aluminum Oxide	X-wt. Cotton	Initial starting specification for all woodworking applications where loading is a problem
Good	R422	Narrow	50-120	Silicon Carbide	X-wt. Cotton	Initial starting specification for all woodworking applications where loading is not an issue
Good	R490	Narrow, Wide	P36-P150	Silicon Carbide	Y-wt. Polyester	Anti-static product for forest product applications (MDF, particle board, plywood) where loading is an issue
Better	H275	Narrow, Wide	P100-P220	Aluminum Oxide	F-wt. Paper	Anti-static wood sanding product where loading is a problem
Good	H448	Narrow, Wide	P80-P220 P280, P320, P400	Silicon Carbide	F-wt. Paper	Anti-static wood sanding product where loading is a problem



CATEGORY DEFINITION

Flap wheels are an ideal choice for a wide variety of blending, deburring and finishing applications common in the metal fabrication, welding and polishing industries. Flap wheels are conformable to intricate shapes and contours. Designed to deliver a consistent finish with a uniform rate of cut, flap wheels wear away, continually exposing fresh abrasives.

- APPLICATIONS:** Used for a wide range of metal fabrication and welding applications including stock removal, blending, deburring, cleaning, finishing, and polishing
- SIZE RANGE:** Flap Wheels with mounted steel shanks: 3/8" - 3" diameter
Flap Wheels with mounted 1/4-20 thread: 1" - 3" diameter
Flap Wheels with arbor holes: 3" - 16" diameter
- GRIT RANGE:** 40 - 320
- ABRASIVE GRAIN:** Ceramic Alumina/Aluminum Oxide, Aluminum Oxide



SHAPE RECOMMENDATION GUIDE

SHAPE

DESCRIPTION/APPLICATION

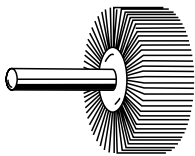

Flap Wheels with Mounted Steel Shanks

Wheels are designed with a 1/8" or 1/4" steel shank as an integral part of each wheel. These shanks run through the wheel creating better balance, a reduction of chatter, and reduced operator fatigue. They also permit quick changes on air tools when using other abrasive products.



Flap Wheels with Mounted 1/4-20 Thread

Wheels are designed with a 1/4"-20 thread and flange as an integral part of the wheel. These threads facilitate the quickest changes on air tools using flap wheels exclusively, as there are no special tools needed to change the flap wheel. Also allow extended reach with accessory mandrels.



Flap Wheels with Arbor Holes

For use on larger portable and fixed-base tools where the wheel must fit on an existing arbor.

APPLICATION/GRIT RECOMMENDATION GUIDE

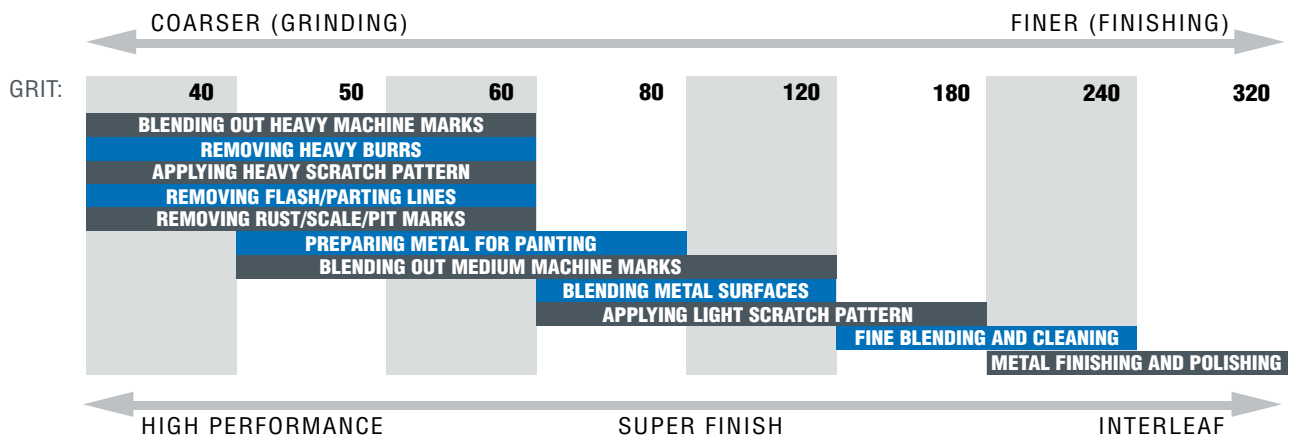

SEE NON-WOVEN FLAP WHEEL SECTION FOR INTERLEAF FLAP WHEELS

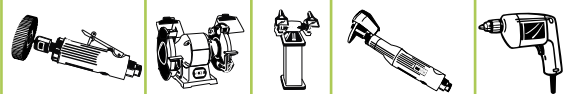

FEATURED PRODUCTS



NEW

NORTON NEON R369 ALUMINUM OXIDE

IDEAL WHEN PURCHASING CRITERIA IS A GOOD-PERFORMING, ECONOMICALLY PRICED, GENERAL PURPOSE FLAP WHEEL

FEATURES

- Premium abrasive and aluminum oxide blend
- New resin system and heavy cotton backing

BENEFITS

- Good choice for hard-to-grind materials (aluminum, brass, bronze, stainless, carbon steel, and titanium) and applications requiring an economical option
- Durable; extended life and reduced edge wear
- Stand up on light- to moderately-demanding applications



MERIT HIGH PERFORMANCE

GOOD CHOICE FOR MORE DURABLE FLAP WHEEL APPLICATIONS WHERE AGGRESSIVE CUT AND SUPERIOR LIFE ARE REQUIRED

FEATURES

- Long-lasting ceramic alumina/aluminum oxide abrasive grain blend
- Heavy cotton backing

BENEFITS

- Aggressive cut and 2 to 3 times longer life
- Extended durability for added life and reduced edge wear



MERIT METAL

GOOD CHOICE WHEN INITIAL PRICE IS THE MAIN CONSIDERATION

FEATURES

- Quality aluminum oxide abrasive
- Engineered, low-cost cotton backing
- Competitive initial price point

BENEFITS

- Good cut rate and life
- Longer life and wear resistance
- Best starting specification for end-user unable to measure total performance





Micro-Mini Flap Wheels with 1/8" Mounted Steel Shanks

- The smallest flap wheels, ranging from 3/8" to 1-3/16" diameter, mounted on a 1/8" diameter steel shank
- Provide fast polishing and light deburring of internal workpieces with holes or grooves as small as 1/2"

AVAILABILITY

TIER:	GOOD	GOOD NEW
BRAND:	Merit	Norton
TRADENAME:	MICRO-MINI	NEON R369
ABRASIVE:	Aluminum Oxide	Aluminum Oxide

TIER:	GOOD	GOOD NEW
BRAND:	Merit	Norton
TRADENAME:	MICRO-MINI	NEON R369
ABRASIVE:	Aluminum Oxide	Aluminum Oxide

D X W X SK.	MAX. RPM	GRIT	STD. PKG.	PART NO.	PART NO.
3/8 x 3/8 x 1/8	40,000	60	10	08834137470	66623399223
		80		08834137471	66623399224
		120		08834137472	66623399225
		180		08834137473	66623399226
		240		08834137474	66623399227
		320		08834137475	66623399228
5/8 x 5/8 x 1/8	37,000	60	10	08834137480	66623399229
		80		08834137481	66623399230
		120		08834137482	66623399231
		180		08834137483	
		240		08834137484	
		320		08834137485	
5/8 x 3/4 x 1/8	37,000	80	10	08834137541	66623399232
		120		08834137542	66623399233
		180		08834137543	
		240		08834137544	
		320		08834137545	
		3/4 x 3/16 x 1/8	35,000	60	10
80				08834137551	
120				08834137552	
180				08834137553	
240				08834137554	
320				08834137555	
3/4 x 3/8 x 1/8	35,000	60	10	08834137560	66623399234
		80		08834137561	66623399235
		120		08834137562	66623399236
		180		08834137563	
		240		08834137564	
		320		08834137565	
3/4 x 1/2 x 1/8	35,000	60	10	08834137570	
		80		08834137571	
		120		08834137572	
		180		08834137573	
		240		08834137574	
		320		08834137575	

D X W X SK.	MAX. RPM	GRIT	STD. PKG.	PART NO.	PART NO.		
3/4 x 5/8 x 1/8	35,000	60	10	08834137580	66623399237		
		80		08834137581	66623399238		
		120		08834137582	66623399239		
		180		08834137583			
		240		08834137584			
		320		08834137585			
3/4 x 3/4 x 1/8	35,000	60	10	08834137590	66623399240		
		80		08834137591	66623399241		
		120		08834137592	66623399242		
		180		08834137593			
		240		08834137594			
		320		08834137595			
3/4 x 3/4 x 1/4	35,000	60	10		66623399243		
		80			66623399244		
		120			66623399245		
		180			66623399246		
		1-3/16 x 1/8 x 1/8	30,000	80	10	08834137491	
				120		08834137492	
180				08834137493			
240				08834137494			
320				08834137495			
1-3/16 x 3/16 x 1/8	30,000			60	10	08834137508	
		80		08834137501			
		120		08834137502			
		180		08834137503			
		240		08834137504			
		320		08834137505			
1-3/16 x 3/8 x 1/8	30,000	80	10	08834137511			
		120		08834137512			
		180		08834137513			
		240		08834137514			
		320		08834137515			



Flap Wheel Test Kits

Micro-Mini Test Kit "MMC"

- Part No. 08834131493
- Includes five wheels, 3/8" to 1-3/16" diameter in various grits, mounted on a 1/8" diameter hardened steel shank
- The "MMC" kit is ideal for fast polishing and light deburring of internal holes or grooves as small as 1/2"



Shank-Mounted Mini Test Kit "CMM"

- Part No. 08834138004
- Includes ten wheels, 1" to 3" diameter in various grits mounted on a 1/4" diameter hardened steel shank



Mini Flap Wheels with 1/4" Mounted Steel Shanks

AVAILABILITY

TIER:

BRAND:

TRADENAME:

ABRASIVE:



D X W X SK.	MAX. RPM	GRIT	STD. PKG.	PART NO.	PART NO.	PART NO.	PART NO.
1 x 1/2 x 1/4	30,000	60	10				08834149800
		80				08834149801	
		120				08834149802	
1 x 5/8 x 1/4	30,000	40	10		08834137105		
		60		66623399074	08834137100	63642502576	
		80		66623399075	08834137101	63642502577	
		120		66623399076	08834137102	63642502578	
		180			08834131536		
		240			08834137104		
		320			08834137357		
1 x 1 x 1/4	30,000	40	10	66623399077	08834131259		08834149803
		50			08834137309		
		60		69957394176	08834137310	63642502580	08834149804
		80		69957394181	08834137311	63642502581	08834149805
		120		69957394182	08834137312	63642502582	08834149806
		180		66623399078	08834137313	63642502583	08834149807
		240		66623399079	08834137114		08834149808
		320		66623399080	08834137315		08834149809
1-3/8 x 5/8 x 1/4	30,000	60	10	66623399247	08834137320	63642502584	
		80		66623399248	08834137321	63642502585	
		120			08834137322		
		180			08834137323		
		240			08834137324		
1-1/2 x 1/2 x 1/4	25,000	60	10				08834149810
		80					08834149811
		120					08834149812
1-1/2 x 1 x 1/4	25,000	40	10	66623399087	08834135140		
		60		66623399088	08834137340	63642502592	08834149816
		80		66623399089	08834137141	63642502593	08834149817
		120		66623399090	08834137142	63642502594	08834149818
		180		66623399249	08834137343		08834149819
		240		66623399250	08834132101		
		320			08834137145		
1-1/2 x 1-1/2 x 1/4	25,000	40	10	66623399251	08834130642		
		60		66623399252	08834130643		
		80		66623399253	08834130644		
		120		66623399254	08834130641		
		180			08834130695		
2 x 1/2 x 1/4	25,000	40	10				08834149820
		60		66623399255		63642502596	08834149821
		80		66623399256		63642502597	08834149822
		120		66623399257			08834149823
		180		66623399258			



Mini Flap Wheels with 1/4" Mounted Steel Shanks CONTINUED

AVAILABILITY



TIER:	GOOD	GOOD	GOOD	GOOD
BRAND:	Norton	Merit	Norton	Merit
TRADENAME:	NEON R369	HIGH PERFORMANCE	METALITE R265	METAL
ABRASIVE:	Aluminum Oxide	Ceramic Alumina/ALO	Aluminum Oxide	Aluminum Oxide

D X W X SK.	MAX. RPM	GRIT	STD. PKG.	PART NO.	PART NO.	PART NO.	PART NO.
2 x 3/4 x 1/4	25,000	40	10		08834137158		
		60		08834137160			
		80		08834137161			
		120		08834137162			
		180		08834137163			
2 x 1 x 1/4	25,000	40	10	66623399094	08834137377		08834149824
		50			08834137169		
		60		69957394183	08834137370	63642502600	08834149825
		80		69957394184	08834137371	63642502601	08834149826
		120		69957394185	08834137372	63642502602	08834149827
		180		66623399095	08834137373	63642502603	08834149828
		240		66623399096	08834137374		
		320		66623399097	08834137375		
2 x 1-1/2 x 1/4	25,000	40	10		08834137183		
		60		66623399098	08834137380		
		80		66623399099	08834137381		
		120		66623399100	08834137382		
		180			08834137383		
		240			08834137384		
2-1/2 x 1/2 x 1/4	20,000	60	10	66623399259		63642502604	
		80		66623399260		63642502605	
		120		66623399261		63642502606	
2-1/2 x 1 x 1/4	20,000	40	10		08834137408		
		60		66623399262	08834137410	63642502608	
		80		66623399263	08834137411	63642502609	
		120		66623399264	08834137412	63642502610	
		180			08834137413		
		240			08834137633		
2-1/2 x 1-1/2 x 1/4	20,000	60	10		08834137420		
		80			08834137421		
		120			08834137422		
3 x 1/2 x 1/4	20,000	40	10				08834149833
		60		66623399265		63642502612	08834149834
		80		66623399266		63642502613	08834149835
		120		66623399267		63642502614	
		180		66623399268			
3 x 3/4 x 1/4	20,000	60	10		08834137440		
		80			08834137441		
3 x 1 x 1/4	20,000	40	10	66623399104	08834137456		08834149836
		60		69957394186	08834137450	63642502620	08834149837
		80		69957394187	08834137451	63642502621	08834149838
		120		69957394188	08834137252	63642502622	08834149839
		180		66623399105	08834137253	63642502623	08834149840
		240		66623399106	08834135339		
3 x 2 x 1/4	12,000	40	10		08834137460		
		60		66623399108	08834137260		
		80		66623399109	08834137261		
		120		66623399110	08834137262		
		180			08834137263		
3 x 2 x 3/8	12,000	60	10		08834135050		
		80			08834135051		
		120			08834135052		



Mini Flap Wheels with 1/4"-20 Thread



AVAILABILITY

TIER:	GOOD	GOOD	GOOD
BRAND:	Norton	Merit	Norton
TRADENAME:	NEON R369	HIGH PERFORMANCE	METALITE R265
ABRASIVE:	Aluminum Oxide	Ceramic Alumina/ALO	Aluminum Oxide

D X W X THD.	MAX. RPM	GRIT	STD. PKG.	PART NO.	PART NO.	PART NO.
1 x 5/8 x 1/4-20	30,000	60	10	66623399111	08834131001	63642502624
		80		66623399112	08834131002	63642502625
		120		66623399113	08834131003	63642502626
1 x 1 x 1/4-20	30,000	40	10		08834131027	
		60		69957394189	08834131008	63642502628
		80		69957394190	08834131009	63642502629
		120		69957394191	08834131010	63642502630
		180		66623399269	08834131011	63642502631
		240			08834131012	
		320			08834131013	
1-3/8 x 5/8 x 1/4-20	30,000	60	10	66623399270	08834132001	63642502632
		80		66623399271	08834132002	63642502633
		120		66623399272	08834132003	63642502634
1-1/2 x 1 x 1/4-20	25,000	60	10	66623399273		
		80		66623399274		
		120		66623399275		
1-5/8 x 1 x 1/4-20	25,000	40	10		08834132051	
		60		08834132015		63642502638
		80		08834132016		63642502639
		120		08834132017		63642502640
		180		08834132018		
		320		08834132020		
2 x 1/2 x 1/4-20	25,000	60	10	66623399276		63642502642
		80		66623399277		63642502643
		120		66623399278		63642502644
		180		66623399279		
2 x 3/4 x 1/4-20	25,000	60	10		08834133008	
		80		08834133009		
		120		08834133010		
		180		08834133011		
2 x 1 x 1/4-20	25,000	40	10		08834133044	
		60		69957394192	08834133015	63642502646
		80		69957394193	08834133016	63642502647
		120		69957394194	08834133017	63642502648
		180		66623399280	08834133018	63642502649
		240			08834133019	
320		08834133020				
2 x 1-1/2 x 1/4-20	25,000	60	10		08834135201	
		80		08834135202		
		120		08834135203		
		180		08834135204		
2-1/2 x 1/2 x 1/4-20	20,000	60	10			63642502604
		80				63642502605
		120				63642502606
2-1/2 x 1 x 1/4-20	20,000	40	10		08834134061	
		60		08834134022		63642502654
		80		08834134023		63642502655
		120		08834134024		63642502656
		180		08834134025		

FOR ADAPTERS FOR FLAP WHEELS WITH 1/4"-20 THREAD, SEE THE END OF THIS SECTION



Mini Flap Wheels with 1/4"-20 Thread CONTINUED

AVAILABILITY



TIER:	GOOD	GOOD	GOOD
BRAND:	Norton	Merit	Norton
TRADENAME:	NEON R369	HIGH PERFORMANCE	METALITE R265
ABRASIVE:	Aluminum Oxide	Ceramic Alumina/ALO	Aluminum Oxide

D X W X THD.	MAX. RPM	GRIT	STD. PKG.	PART NO.	PART NO.	PART NO.
3 x 1/2 x 1/4-20	20,000	60	10			63642502659 63642502660
		80				
		120				
		180				
3 x 3/4 x 1/4-20	20,000	60	10		08834135008 08834135009 08834135010	
		80				
		120				
3 x 1 x 1/4-20	20,000	40	10	69957394195 69957394196 69957394197 66623399281	08834135230 08834135015 08834135016 08834135017 08834135018 08834135019	63642502664 63642502665 63642502666
		60				
		80				
		120				
		180				
		240				
		320				

FOR ADAPTERS FOR FLAP WHEELS WITH 1/4"-20 THREAD, SEE THE END OF THIS SECTION



Cup-Type Mini Flap Wheels with 1/4" Mounted Steel Shanks

- Primarily used for bottom or side-wall type sanding where conventional tools do not reach
- Cup-type mini flap wheels will not mar your workpiece while reaching flush into areas where other wheels cannot

AVAILABILITY

TIER:	GOOD
BRAND:	Merit
ABRASIVE:	Aluminum Oxide

D X W X SK.	MAX. RPM	GRIT	STD. PKG.	PART NO.
2-1/2 x 1-1/2 x 1/4	20,000	60	10	08834144463



Flap Wheel Test Kits

Merit Mini 1/4"-20 Thread Test Kit "CQ"

- Part No. 08834138001
- Includes ten, 1" to 3" diameter, 1/4"-20 thread mini flap wheels
- Each kit includes a 1/4"-20 QC-4 quick-change adapter

Merit Mini Grind-O-Flex Test Kit "CMM"

- Part No. 08834138004
- Includes ten wheels, 1" to 3" diameter in various grits
- Each wheel comes with a 1/4" steel mandrel permanently mounted

Merit Micro Mini GOF Test Kit "MMC"

- Part No. 08834131493
- Includes 5 wheels, 3/8" to 1-3/16" in diameter
- The flap wheels are mounted on a 1/8" diameter hardened steel shank
- Ideal for fast polishing and light deburring of holes or grooves



3-1/2" – 8" Flap Wheels with Arbor Holes

AVAILABILITY



TIER:	GOOD	GOOD	GOOD
BRAND:	Norton	Merit	Norton
TRADENAME:	NEON R369	HIGH PERFORMANCE	METALITE R265
ABRASIVE:	Aluminum Oxide	Ceramic Alumina/ALO	Aluminum Oxide

D X W X H	MAX. RPM	GRIT	STD. PKG.	PART NO.	PART NO.	PART NO.
3-1/2 x 1 x 5/8	12,000	40	10		08834122001	63642502668 63642502669
		50			08834122002	
		60			08834122003	
		80			08834122004	
		120			08834122006	
		180			08834122007	
		240			08834122008	
3-1/2 x 1-1/2 x 5/8	12,000	40	10		08834122009	
		50			08834122011	
		60			08834122012	
		80			08834122013	
		120			08834122014	
		150			08834122016	
		180			08834122017	
3-1/2 x 2 x 5/8	12,000	40	10		08834122018	
		60			08834122020	
		80			08834122022	
		120			08834122024	
		180			08834122025	
4 x 1 x 5/8	12,000	40	10		08834122027	63642502673 63642502674 63642502675
		60			08834122028	
		80			08834122032	
		120			08834122033	
		180			08834122034	
		240			08834122035	
		320			08834122037	
4 x 1-1/2 x 5/8	12,000	40	10		08834122038	
		50			08834122039	
		60			08834122040	
		80			08834122042	
		120			08834122043	
		240			08834122044	
4 x 2 x 5/8	12,000	40	10		08834122045	63642502677
		50			08834122047	
		60			08834122049	
		80			08834122050	
		120			08834122053	
		180			08834122054	
		320			08834122055	
5 x 1 x 5/8	6,200	40	5	66623399282 66623399283 66623399284 66623399285	08834122056	63642502678
		60			08834122058	
		80			08834122059	
		120			08834122060	
5 x 1-1/2 x 5/8	12,000	40	10		08834122061	
		50			08834122063	
		60			08834122064	
		80			08834122065	
		120			08834122066	
		180			08834122068	
		320			08834122070	
6 x 1/2 x 1	6,000	40	10		08834122071	
		60			08834122072	
		80			08834123001	
		120			08834123003	
		150			08834123004	
		180			08834123005	
		320			08834123006	

FOR FLAP WHEEL WITH ARBOR HOLE ADAPTERS AND BUSHINGS, SEE THE END OF THIS SECTION



3-1/2" – 8" Flap Wheels with Arbor Holes CONTINUED

AVAILABILITY



TIER:	GOOD	GOOD	GOOD	GOOD
BRAND:	Norton	Merit	Norton	Merit
TRADENAME:	NEON R369	HIGH PERFORMANCE	METALITE R265	METAL
ABRASIVE:	Aluminum Oxide	Ceramic Alumina/ALO	Aluminum Oxide	Aluminum Oxide

D x W x H	MAX. RPM	GRIT	STD. PKG.	PART NO.	PART NO.	PART NO.	PART NO.			
6 x 1 x 1	6,000	40	5		08834123009		08834120167			
		50		08834123010		08834120168				
		60		69957394198	08834123011	63642502680	08834120169			
		80		69957394199	08834123012	63642502681	08834120170			
		100					08834120171			
		120		69957394200	08834123014	63642502682	08834120172			
		150			08834123015					
		180			08834123016		08834120174			
		240			08834123017		08834120176			
		320			08834123018		08834120177			
		6 x 1-1/2 x 1		6,000	40	5	66623399286	08834123020		
					50		08834123021			
60	66623399287		08834123022		63642502686					
80	66623399288		08834123023		63642502687					
120	66623399289		08834123025							
150			08834123026							
180			08834123027							
240			08834123028							
320			08834123029							
6 x 2 x 1	6,000		40		5		66623399290	08834123031	63642502689	08834120189
			50				08834123032			
			60				66623399291	08834123033	63642502691	08834120191
		80	66623399292	08834123034		63642502692	08834120192			
		100					08834120198			
		120	66623399293	08834123036		63642502694	08834120194			
		180	66623399294	08834123038			08834120197			
		240		08834123039			08834120199			
		320		08834123040			08834120493			
		6 x 3 x 1	6,000	40		3		08834123053		
				50			08834123054			
				60			08834123055			
80	08834123056			63642502696						
120	08834123058									
150	08834122544									
180	08834123060									
240	08834123061									
320	08834122329									
8 x 1 x 1	4,500			40	3			08834123070		
				50			08834123071			
				60			66623399295	08834123072		
		80	66623399296	08834123073		63642502698				
		120	66623399297	08834123075						
		180		08834123077						
		320		08834123079						
8 x 2 x 1	4,500	40	3		08834123092					
		50		08834123093						
		60		08834123094	63642502700					
		80		08834123095	63642502701					
		120			08834123097					
		180			08834123099					
		240			08834123100					
		320			08834123101					

FOR FLAP WHEEL WITH ARBOR HOLE ADAPTERS AND BUSHINGS, SEE THE END OF THIS SECTION

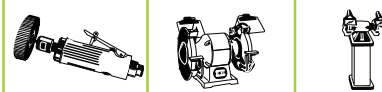

Adapter and Bushings for Flap Wheels with Arbor Holes

WHEEL DIAMETER	ADAPTERS	PART NO.
Shank Adapters		
3-1/2	1/4 Shank	08834125001
3-1/2	3/8 Shank	08834125007
4-8	1/4 Shank	08834125003
Threaded Mounting Adapters		
4-8	5/8-11 Thread	08834125027
Reducing Bushings		
6-8	1 to 3/8	08834125016
	1 to 1/2	08834125017
	1 to 5/8	08834125018
	1 to 3/4	08834125019
	1 to 7/8	08834125020
10-16	1 to 5/8	08834122069

STANDARD PACKAGES = 1 ADAPTER, 1 PAIR OF BUSHINGS



Adapters for 1/4"-20 Thread Mini and Arbor Hole Flap Wheels

MODEL	DESCRIPTION	PART NO.
Adapters		
ADAPT C	Fits 3 x 2 x 3/8 arbor flap wheel	08834137009
MA-100	Fits A.H. Mini Wheel	08834137007
QC-8	1/8 x 5/8	08834137002
QC-4	1/4 SK. Dia. x 5/8 SK. L.	08834137001
QC-44	1/4 x 4	08834137003
QC-46	1/4 x 6	08834137004
QC-48	1/4 x 8	08834137005
QC-T	1/4-20 Thread	08834137012
QC-T	3/8-24 Thread	08834137010

STANDARD PACKAGE = 1 ADAPTER
OTHER THREAD SIZES AVAILABLE FOR QUOTATION

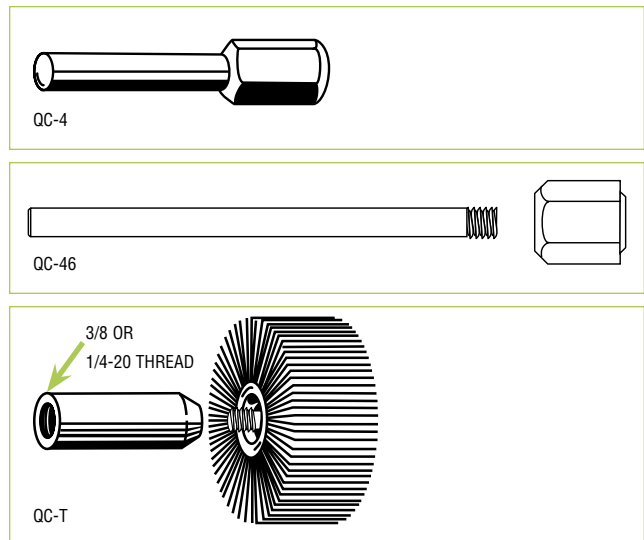



Sand-O-Flex Wheels

With their firm cushioning brushes, Sand-O-Flex's abrasive strips are forced into, around and over corners, hollow and fluted surfaces, and small openings. Pressure is distributed evenly over the surface to prevent loss of detail and the flattening of rounded areas; for sanding metals, woods, plastics, rubber and ceramic.

Sand-O-Flex wheels are designed to fit most standard equipment. They load quickly and easily by turning the index knob as needed, allowing you to change grit size in minutes. Sand-O-Flex refills are available both scored (for finer, less aggressive work) and unscored. And, with the use of Merit adapters, Sand-O-Flex wheels will fit most electric bench grinders.



Sand-O-Flex Wheels – Model 350-RP

- Diameter: 6-1/2" overall, 4" diameter high-impact plastic body
- 1" wide abrasive strips backed by 8 cushioning brushes
- 1/4" diameter steel shank
- Weight: 9-1/2 oz.
- Maximum operating speed: 2,400 RPM
- Special adapter required for bench grinder use
- Some assembly required



AVAILABILITY

TIER:	GOOD
BRAND:	Merit
TRADENAME:	SAND-O-FLEX
ABRASIVE:	Aluminum Oxide

MODEL NO.	GRIT	PART NO.	
Sand-O-Flex Wheel			
350-RP		08834111051	
Comes assembled with 80 grit A/O Resin Bond Scored refill and brushes			
Sand-O-Flex Accessories			
Bench Grinder Adapter 350-RP 1/4 Shank to 1/2 Shank		08834111055	
Replacement Brushes for 350-RP; 8 per set		08834113003	
Resin Bond Refills			
350-RP SCORED 10/box	60	08834111052	
	80	08834111053	
	100	08834112114	
	120	08834111054	
	180	08834111057	
350-RP UNSCORED 10/box	60	08834112031	
	80	08834111059	
	100	08834112021	
	120	08834112032	
	180	08834112033	
Glue Bond Refills			
350-RP SCORED 10/box	60	08834112053	
	80	08834112054	
	100	08834112055	
	120	08834112056	
	150	08834112057	
	180	08834112058	
	240	08834112059	
	320	08834112060	
	350-RP UNSCORED 10/box	60	08834112043
		80	08834112044
100		08834112045	
120		08834112046	
150		08834112047	
180		08834112048	
240	08834112049		
320	08834112050		



CATEGORY DEFINITION

Best product for blending and polishing contours when smooth running is a primary concern. Used for finishing hard-to-reach areas, removing parting lines, imperfections, and burrs on all surfaces.

- BENEFITS:**
- Spiral construction avoids shadow marks and provides smooth, chatter-free cutting action
 - Achieves close tolerances when finishing curved, contoured, and hard-to-reach areas
 - Fast cutting and removes toughest metal
 - Bands are easily removed and replaced
- GRIT RANGE:** 24 - 320
- ABRASIVE GRAIN:** Aluminum Oxide
- OTHER:** Use with rubber expanding drum

APPLICATION/GRIT RECOMMENDATION GUIDE

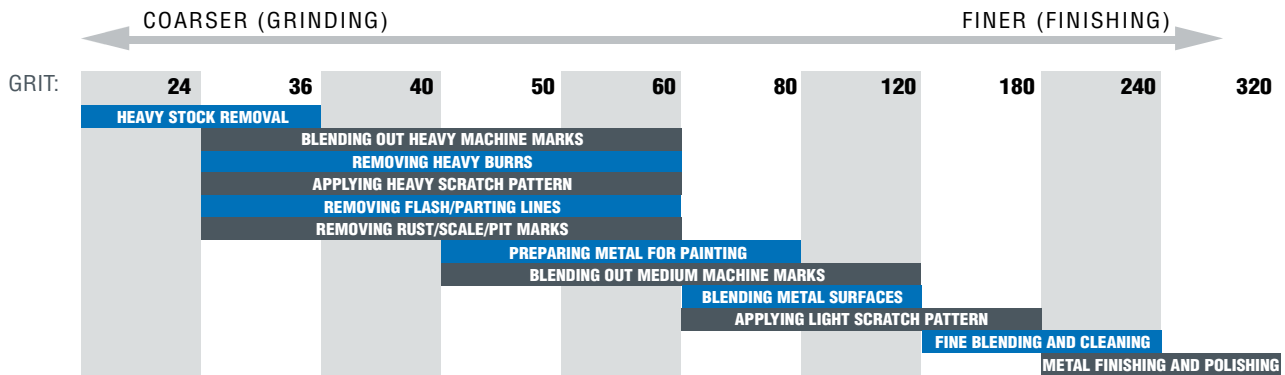



AVAILABILITY

GRIT	GOOD							
	1/4 x 1/2	1/4 x 1	3/8 x 1/2	3/8 x 1	1/2 x 1/2	1/2 x 1	1/2 x 1-1/2	1/2 x 2
24	-	-	-	-	-	08834196712	-	-
36	-	-	-	08834197674	08834196619	08834196591	08834196237	08834196758
40	08834196614	-	-	-	08834196234	08834196174	-	08834196825
50	08834196292	08834196785	08834196386	-	08834196228	08834196214	08834197111	08834196548
60	08834196342	08834196886	08834196829	08834196999	08834196068	08834196212	08834196053	08834196549
80	08834196269	08834196733	08834196512	08834196645	08834196179	08834196215	08834196646	08834196669
100	08834196511	08834196734	08834196513	-	08834196189	08834196534	08834196540	08834196735
120	08834196217	08834197004	08834196747	08834196218	08834196069	08834196210	08834196324	08834196736
150	08834196327	-	-	-	08834196211	08834196772	-	-
180	08834196490	-	08834196504	-	08834196209	08834196713	-	-
240	-	-	08834196481	-	08834196564	08834196814	-	-
320	08834196865	-	08834196830	-	08834196505	08834196487	-	-
PKG. QTY. STOCK	100/box	100/box	100/box	100/box	100/box	100/box	100/box	100/box
MOQ NON-STOCK	400	400	300	300	300	300	300	200
Expanding Rubber Drums								
	1/8 Shank 30,000 RPM 08834196030	1/8" shank 30,000 8834196008	1/8 Shank 30,000 RPM 08834196944	1/8 Shank 18,000 RPM 08834196011	1/4 Shank 30,000 RPM 08834196904	1/4 Shank 15,000 RPM 08834196906	1/4 Shank 12,000 RPM 08834196907	1/4 Shank 10,000 RPM 08834196908



AVAILABILITY

GOOD								
GRIT	3/4 x 1/2	3/4 x 3/4	3/4 x 1	3/4 x 1-1/2	3/4 x 2	1 x 1/2	1 x 1	1 x 1-1/2
24	-	08834196613	08834196776	08834196596	-	-	08834196563	08834196708
36	08834196769	08834196609	08834196261	08834196238	08834196953	08834196058	08834196072	08834196525
40	08834196605	08834196236	08834196517	08834196227	08834196826	-	08834196073	08834196546
50	08834196608	08834196183	08834196515	08834196500	08834196757	-	08834196184	08834196078
60	08834196578	08834196168	08834196070	08834196554	08834196745	08834196580	08834196075	08834196060
80	08834196255	08834196161	08834196071	08834196249	08834196756	08834196647	08834196074	08834196162
100	08834196567	08834196230	08834196502	08834196501	08834196766	08834196157	08834196167	08834196257
120	08834196579	08834196226	08834196219	08834196057	08834196746	08834197592	08834196177	08834196677
150	08834196631	08834196231	08834196822	-	08834197283	-	08834196686	08834197639
180	08834197116	08834196056	08834196565	08834196851	-	-	08834196059	08834196790
240	08834196603	08834196859	08834196668	-	66254410751	08834197287	08834196178	08834196526
320	08834196806	-	08834196624	08834199664	-	-	08834196789	08834197700
PKG. QTY. STOCK	100/box	100/box	100/box	100/box	100/box	100/box	100/box	100/box
MOQ NON-STOCK	300	300	300	300	200	200	300	200
Expanding Rubber Drums								
	1/4 Shank 27,000 RPM 08834196909	1/4 Shank 24,000 RPM 08834196910	1/4 Shank 17,000 RPM 08834196911	1/4 Shank 10,000 RPM 08834196912	1/4 Shank 10,000 RPM 08834196913	1/4 Shank 20,000 RPM 08834196914	1/4 Shank 18,000 RPM 08834196916	1/4 Shank 10,000 RPM 08834196917

GOOD								
GRIT	1 x 2	1 x 3	1-1/2 x 1	1-1/2 x 1-1/2	1-1/2 x 2	1-1/2 x 3	2 x 1	2 x 1-1/2
24	08834196709	08834197806	08834196684	08834196220	08834196539	-	08834196841	08834196700
36	08834196267	08834196665	08834196222	08834196164	08834196657	08834197063	08834196233	08834196509
40	08834196689	-	08834196223	08834196171	08834196598	-	08834196109	08834196514
50	08834196588	08834197688	08834196185	08834196176	08834196252	-	08834196186	08834196527
60	08834196506	08834196676	08834196503	08834196091	08834196067	08834196703	08834196232	08834196978
80	08834196268	08834196195	08834196254	08834196165	08834196533	08834196809	08834196166	08834196259
100	08834196750	08834196445	08834196216	08834196182	08834196543	08834196522	08834196508	08834196521
120	08834196507	08834196197	08834196707	08834196066	08834196079	08834196343	08834196595	08834196586
150	08834197664	-	08834196989	08834197750	08834197376	-	-	-
180	08834196987	08834196356	-	08834196535	-	08834197869	08834196661	08834196536
240	-	-	08834196491	08834196260	08834197709	-	08834197983	-
320	-	-	08834196063	08834197647	-	-	-	-
PKG. QTY. STOCK	100/box	100/box	100/box	100/box	100/box	100/box	100/box	100/box
MOQ NON-STOCK	200	100	300	200	200	100	200	200
Expanding Rubber Drums								
	1/4 Shank 8,000 RPM 08834196918	NA	1/4 Shank 12,000 RPM 08834196921	1/4 Shank 10,000 RPM 08834196922	1/4 Shank 8,000 RPM 08834196923	NA	1/4 Shank 11,000 RPM 08834196926	1/4 Shank 8,000 RPM 08834196927

GOOD							
GRIT	2 x 2	2 x 3	2-1/4 x 3	3 x 1	3 x 1-1/2	3 x 2	3 x 3
24	08834196516	08834197903	-	08834196795	08834197056	08834196263	08834196256
36	08834196110	08834196827	08834197140	08834196717	08834196802	08834196545	08834196262
40	08834196172	08834196151	08834197158	08834196755	-	08834196090	08834196555
50	08834196187	08834196152	08834196620	-	-	08834196264	08834196253
60	08834196173	08834196175	-	08834196150	08834196719	08834196530	08834196188
80	08834196181	08834196198	08834196270	08834196524	08834196633	08834196265	08834196159
100	08834196193	08834196199	-	08834196831	-	-	08834196250
120	08834196585	08834196200	08834196729	08834196089	-	08834196531	08834196572
150	08834196629	-	08834195857	-	-	-	08834196452
180	08834196306	-	-	-	-	-	08834196131
240	08834196375	-	-	-	-	-	08834196574
320	08834196628	-	08834195825	-	-	-	08834197968
PKG. QTY. STOCK	100/box	100/box	100/box	100/box	100/box	100/box	100/box
MOQ NON-STOCK	200	100	100	200	200	100	100
Expanding Rubber Drums							
	1/4 Shank 6,000 RPM 08834196928	1/4" shank 6,000 RPM 8834196010	NA	3/8 Shank 3,000 RPM 08834196929	NA	3/8 Shank 3,000 RPM 08834196930	3/8 Shank 3,000 RPM 08834196931



CATEGORY DEFINITION

Cartridge, spiral rolls and cone points are strips of abrasive cloth rolled and glued to form a solid shape that is designed to break down during use and reveal the next layer of abrasive.

APPLICATIONS: Used on inside surfaces and inside corners where other forms of abrasive cannot reach. Typically these are used on high speed air grinders and are always mounted on a mandrel. Ideal for flash removal, polishing, or removing machine tool marks, and edge breaking.

SHAPES: Cartridge Rolls, Spiral Rolls (Full Taper, Half Taper, and Sidewall Taper), Tapered Cone Points

GRIT RANGE: 36 - 320

ABRASIVE GRAIN: Ceramic Alumina, Aluminum Oxide, Silicon Carbide

BACKING: Cotton Cloth

MAXIMUM RPM: 1/8" to 1/2" – 23,000
 5/8" to 1" – 18,000
 1" to 1-1/2" – 15,000



APPLICATION/GRIT RECOMMENDATION GUIDE

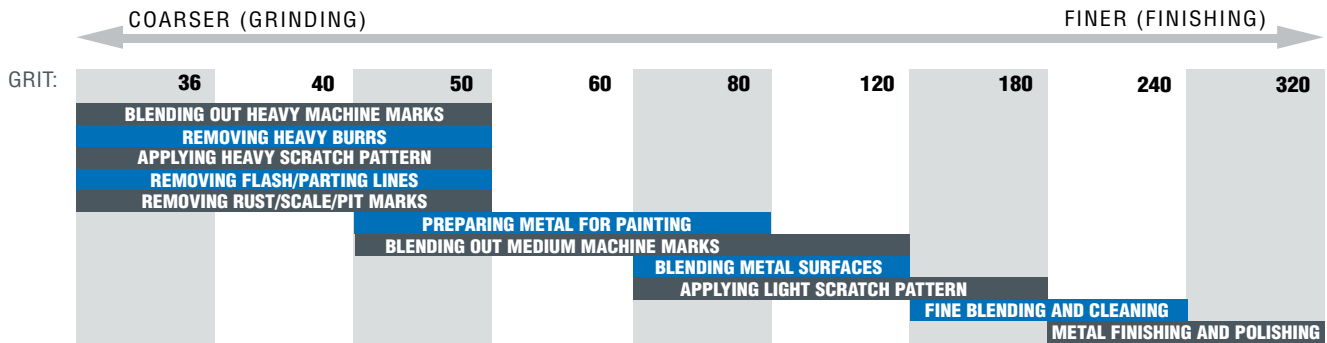

FEATURED PRODUCTS



MERIT BLAZE

FOR HARD-TO-GRIND MATERIALS – STAINLESS STEEL, COBALT, INCONEL, AND TITANIUM

FEATURES

- Next-generation ceramic alumina abrasive grain
- Advanced grinding aid
- Improved resin bond system

BENEFITS

- Significantly faster cut rates
- Resists wear, resulting in 50% – 300% longer life
- Greatest productivity
- Cooler cutting, longer life
- Exceptional grain retention and longer life

Refer to the back of this section for mandrels.



Cartridge Rolls

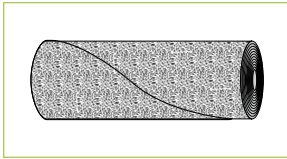

- Effective for flash removal
- Polishing or removing machine tool marks
- Edge breaking
- Valuable abrasive tool for reaching into corners, where larger diameter tools cannot work
- All cartridge roll part numbers shown are resin bond, half-glued
- Quarter and full glue are also available for quotation

FEATURED PRODUCTS



Merit Blaze Cartridge Rolls

- With their exclusive ceramic grain technology, grinding aid, and X-weight cotton backing, Merit Blaze products outperform all competitive ceramic, zirconia, and aluminum oxide specialty products in today's markets
- Merit Blaze specialties cut cooler and last longer on stainless steel, cobalt, Inconel, titanium and other hard-to-grind materials

AVAILABILITY

			TIER: BEST
			ABRASIVE: Ceramic Alumina
			BACKING: Cotton
			OTHER: Supersized
D x L x H	GRIT	STD. PKG.	PART NO.
1/4 x 1-1/2 x 1/8 Use M-9 Mandrel	60	100	66261194384
	80		66261194394
	120		66261194397
3/8 x 1-1/2 x 1/8 Use M-9 Mandrel	60	100	66261194392
	80		66261194395
	120		66261194398
1/2 x 1-1/2 x 1/8 Use M-9 Mandrel	60	100	66261194393
	80		66261194396
	120		66261194399



Merit Silicon Carbide Cartridge Rolls

- Sharp silicon carbide grain penetrates tough, difficult-to-grind materials, as well as soft, loading materials:
 - titanium
 - masonry
 - composites
 - plastic
 - rubber

AVAILABILITY

			TIER: GOOD
			ABRASIVE: Silicon Carbide
			BACKING: Cotton
D x L x H	GRIT	STD. PKG.	PART NO.
1/4 x 1-1/2 x 1/8 Use M-9 Mandrel	60	100	08834183274
	80		08834182359
	120		08834189131
3/8 x 1-1/2 x 1/8 Use M-9 Mandrel	60	100	08834181309
	80		08834180710
	120		66261042229
1/2 x 1-1/2 x 1/8 Use M-9 Mandrel	60	100	08834189233
	80		08834180712
	120		66261086969



Merit Aluminum Oxide Cartridge Rolls

- Most effective starting specification for flash removal, polishing or removing machine tool marks and edge breaking on all types of metal

AVAILABILITY

			TIER: GOOD
			ABRASIVE: Aluminum Oxide
			BACKING: Cotton
D x L x H	GRIT	STD. PKG.	PART NO.
1/4 x 3/4 x 1/8 Use M-3 or M-7 Mandrel	60	100	08834180042
	80		08834180043
	120		08834180045
1/4 x 1 x 1/8 Use M-4 or M-8 Mandrel	50	100	08834180060
	60		08834180061
	80		08834180062
	100		08834180063
	120		08834180064
	150		08834180065
	180		08834180066
	240		08834180068
	320		08834180070
1/4 x 1-1/2 x 1/8 Use M-9 Mandrel	50	100	08834180079
	60		08834180080
	80		08834180081
	100		08834180082
	120		08834180083
	150		08834180084
	180		08834180085
	320		08834180089
	1/4 x 2 x 1/8 Use M-10 Mandrel		80
100		08834180101	
120		08834180102	

AVAILABILITY

			TIER: GOOD
			ABRASIVE: Aluminum Oxide
			BACKING: Cotton Cloth
DIA. x L. x A.H.	GRIT	STD. PKG.	PART NO.
3/16 x 3/4 x 3/32	80	100	08834180005
3/16 x 1 x 3/32 Use M-2E Mandrel	60	100	08834180023
	80		08834180024
	100		08834180025
	120		08834180026
	150		08834180027
	180		08834180028
	240		08834180030
	320		08834180032

Refer to the back of this section for mandrels.

CONTINUED

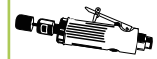

Merit Aluminum Oxide Cartridge Rolls CONTINUED

AVAILABILITY

D x L x H	GRIT	STD. PKG.	TIER: GOOD
			ABRASIVE: Aluminum Oxide BACKING: Cotton
			PART NO.
5/16 x 1 x 1/8 use M-4 or M-8 Mandrel	60	100	08834180137
	80		08834180138
	120		08834180140
5/16 x 1-1/2 x 1/8 use M-9 Mandrel	60	100	08834180156
	80		08834180157
	120		08834180159
3/8 x 3/4 x 1/8 use M-7 Mandrel	60	100	08834180194
	80		08834180195
	120		08834180197
3/8 x 1 x 1/8 use M-8 Mandrel	40	100	08834180211
	50		08834180212
	60		08834180213
	80		08834180214
	100		08834180215
	120		08834180216
	150		08834180217
3/8 x 1-1/2 x 1/8 use M-9 Mandrel	180		08834180218
	240		08834180220
	36	100	08834180228
	40		08834180229
	50		08834180230
	60		08834180231
	80		08834180232
3/8 x 2 x 1/8 use M-10 Mandrel	100		08834180233
	120		08834180234
	150		08834180235
	180		08834180236
	240		08834180238
	320		08834180240
	60	100	08834180250
1/2 x 3/4 x 1/8 use M-7 Mandrel	80	100	08834180251
	100		08834180252
	120		08834180253
	150		08834180270
1/2 x 1 x 1/8 use M-8 Mandrel	40	100	08834180286
	50		08834180287
	60		08834180288
	80		08834180289
	100		08834180290
	120		08834180291
	150		08834180292
	180		08834180293
	240		08834180295
	320		08834180297
	1/2 x 1-1/2 x 1/8 use M-9 Mandrel	36	100
40			08834180305
50			08834180306
60			08834180307
80			08834180308
100			08834180309
120			08834180310
150			08834180311
180			08834180312
240			08834180314
320			08834180316
1/2 x 1-1/2 x 3/16 use M-16 Mandrel	120	100	08834180919
1/2 x 2 x 1/8 use M-10 Mandrel	60	100	08834180326
	80		08834180327
	100		08834180328
	120		08834180329
	180		08834180331
	240		08834180333
	320		08834180335
1/2 x 2 x 3/16 use M-17 Mandrel	60	100	08834180350
	80		08834180653
	120		08834180338

CONTINUED

D x L x H	GRIT	STD. PKG.	TIER: GOOD
			ABRASIVE: Aluminum Oxide BACKING: Cotton
			PART NO.
1/2 x 2 x 1/4 use M-22 Mandrel	40	100	08834183168
	80		08834180351
	120		08834180364
5/8 x 1 x 3/16 use M-15 Mandrel	80	100	08834180364
	36	100	08834180395
	40		08834180392
	50		08834180393
	60		08834180275
5/8 x 1-1/2 x 1/8 use M-9 Mandrel	80		08834180789
	120		08834180394
	50	100	08834180381
	60		08834180382
	80		08834180383
5/8 x 2 x 1/8 use M-10 Mandrel	60	100	08834182505
	80		08834181080
	100		08834180400
5/8 x 2 x 3/16 use M-10 Mandrel	50	100	08834180400
	60		08834180401
	80		08834180402
	100		08834180403
	120		08834180469
3/4 x 1 x 1/8 use M-8 Mandrel	80	100	08834181543
	120		08834180456
	150		08834180459
3/4 x 1 x 3/16 use M-15 Mandrel	40	100	08834180461
	80		08834180069
	120		08834180490
	150		08834180527
	180		08834180487
3/4 x 1-1/2 x 1/8 use M-9 Mandrel	40	100	08834180474
	60		08834180475
	80		08834180476
	100		08834180477
	120		08834180478
	150		08834180479
	180		08834180480
3/4 x 1-1/2 x 3/16 use M-16 Mandrel	36	100	08834180482
	40		08834180907
	50		08834180489
	60		08834180358
	80		08834180523
	100		08834180488
	120		08834182807
3/4 x 2 x 1/8 use M-10 Mandrel	150		08834180791
	40	100	08834180494
	60		08834180496
	80		08834180497
	100		08834180498
3/4 x 2 x 3/16 use M-17 Mandrel	120		08834180499
	150		08834180506
	180		08834181297
	60	100	08834180509
	80		08834180507
1 x 1-1/2 x 1/8 use M-9 Mandrel	100		08834180580
	120		08834180584
	150		08834181195
1 x 1-1/2 x 1/4 use M-21 Mandrel	36	100	08834180587
	60		08834180583
	80		08834180589
1 x 2 x 3/16 use M-17 Mandrel	40	100	08834180589
	60		08834180591
	80		08834180592
1 x 2 x 1/4 use M-22 Mandrel	60	100	08834180603
	80		08834180606
	120		08834180585

Refer to the back of this section for mandrels.



Spiral Rolls

- All spiral roll part numbers shown are full tapered, resin bond, half glued
- Half-tapered and sidewall-tapered are available for quotation
- Quarter and full glue are also available for quotation

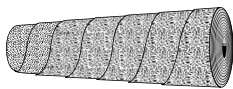

Full Taper

- Especially useful for grinding/polishing of channels, fillets and radii, and deburring small holes
- Full taper used when the area to finished is hard to reach with a full cartridge roll
- The tapered roll conforms to smaller areas
- Fits into irregular concaves, contours, channels

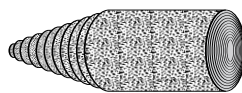

Half Taper

- Used when the area to be finished is not narrow but a beginning point on the roll is needed
- The portion of the roll that is not tapered is then used to finish off the sides



Sidewall Taper

- The portion of the roll that is tapered guides the roll down to the area to be finished
- The sidewall then finishes off the sides

FEATURED PRODUCTS



**Merit Blaze
Spiral Rolls Full Taper**

- With their exclusive ceramic grain technology, grinding aid and X-weight cotton backing, these products outperform all competitive ceramic, zirconia, and aluminum oxide specialty products in today's markets
- Merit Blaze specialties cut cooler and last longer on stainless steel, cobalt, Inconel, titanium, and other hard-to-grind materials

AVAILABILITY

			TIER: BEST
			ABRASIVE: Ceramic Alumina
			BACKING: Cotton
			OTHER: Supersized
D x L x H	GRIT	STD. PKG.	PART NO.
3/8 x 1-1/2 x 1/8 Use M-9 Mandrel	60	100	66261194481
	80		66261194490
	120		66261194491
1/2 x 1-1/2 x 1/8 Use M-9 Mandrel	60	100	66261194484
	80		66261194492
	120		66261194495



**Merit Silicon Carbide
Spiral Rolls Full Taper**

- Sharp silicon carbide grain penetrates tough, difficult-to-grind materials as well as soft, loading materials:
 - titanium
 - masonry
 - composites
 - plastic
 - rubber

AVAILABILITY

			TIER: GOOD
			ABRASIVE: Silicon Carbide
			BACKING: Cotton
D x L x H	GRIT	STD. PKG.	PART NO.
3/8 x 1-1/2 x 1/8 use M-9 Mandrel	60	100	08834189901
	80		08834189904
	120		66261046936
1/2 x 1-1/2 x 1/8 use M-9 Mandrel	60	100	66261185977
	80		08834183460
	120		08834183448

Refer to the back of this section for mandrels.

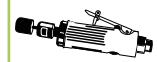

Merit Aluminum Oxide Spiral Rolls Full Taper

- Especially useful for grinding/polishing of channels, fillets and radii, and deburring small holes
- All spiral roll part number shown are full tapered, resin bond, half glued
- Half-tapered and sidewall tapered are available for quotation
- Quarter and full glue are also available for quotation

AVAILABILITY

D x L x H	GRIT	STD. PKG.	TIER:	GOOD
			ABRASIVE:	Aluminum Oxide
			BACKING:	Cotton
D x L x H	GRIT	STD. PKG.	PART NO.	
3/8 x 1 x 1/8 use M-8 Mandrel	60	100	08834181714	
	80		08834181715	
	120		08834181717	
	180		08834181719	
3/8 x 1-1/2 x 1/8 use M-9 Mandrel	50	100	08834181723	
	60		08834181724	
	80		08834181708	
	120		08834181727	
	150		08834181728	
	180		08834181709	
1/2 x 1 x 1/8 use M-8 Mandrel	60	100	08834181734	
	80		08834181735	
	120		08834181737	
	180		08834181739	
1/2 x 1-1/2 x 1/8 use M-9 Mandrel	36	100	08834181230	
	40		08834181742	
	50		08834181743	
	60		08834181744	
	80		08834181745	
	100		08834181746	
	120		08834181747	
	180		08834181749	
240		08834181750		

CONTINUED

D x L x H	GRIT	STD. PKG.	TIER:	GOOD
			ABRASIVE:	Aluminum Oxide
			BACKING:	Cotton
D x L x H	GRIT	STD. PKG.	PART NO.	
1/2 x 2 x 1/8 use M-10 Mandrel	60	100	08834181754	
	80		08834181755	
	120		08834181757	
5/8 x 1-1/2 x 1/8 use M-9 Mandrel	100	100	08834181776	
	120		08834181777	
	240		08834183313	
	320		08834181781	
5/8 x 1-1/2 x 3/16 use M-16 Mandrel	80	100	08834181444	
3/4 x 1-1/2 x 1/8 use M-9 Mandrel	60	100	08834181286	
	80		08834180886	
3/4 x 1-1/2 x 3/16 use M-16 Mandrel	50	100	08834181807	
	60		08834181808	
	80		08834181809	
	120		08834181811	
3/4 x 2 x 3/16 use M-17 Mandrel	60	100	08834181820	
1 x 1-1/2 x 1/8 use M-9 Mandrel	60	100	08834181240	
1 x 2 x 3/16 use M-17 Mandrel	36	100	08834181875	
	60		08834181878	
	80		08834181879	

Merit Aluminum Oxide Tapered Cone Points



- Tapered cone points are similar to cartridge rolls but their shape lends greater accessibility to many difficult-to-reach work areas
- They are used for deburring holes and in close tolerance work areas
- Popular sizes and mandrels are listed, with additional sizes available upon request

FEATURED PRODUCTS



AVAILABILITY

D x L x H	GRIT	STD. PKG.	TIER:	GOOD
			ABRASIVE:	Aluminum Oxide
			BACKING:	Cotton
D x L x H	GRIT	STD. PKG.	PART NO.	
5/16 x 1-1/2 x 5° Use B-20 Mandrel	80	500	08834180873	
	100		08834182043	
	120		08834182717	
	150		08834186890	
	180		08834182535	
	240		08834182044	
3/16 x 1 x 2-1/2° Use K-110 Mandrel	320		08834182537	
	50	500	08834186892	
	60		08834186893	
	80		08834180918	
	100		08834182197	
	120		08834182199	
	150		08834182200	
	180		08834186894	
240		08834186895		



Cartridge and Spiral Roll Mandrels

MODEL NO.	PILOT DIA.	PILOT LENGTH	SHANK DIA.	SHANK LENGTH	OVERALL LENGTH	PART NO.
Cartridge and Spiral Roll Mandrels						
M-2E	3/32	3/4	1/4	1	3	08834183799
M-2	3/32	1	1/8	1	3	08834181202
M-3	1/8	1/2	1/8	1	2-1/2	08834181203
M-4	1/8	3/4	1/8	1	2-1/2	08834181204
M-5	1/8	1	1/8	1	2-3/4	08834181205
M-6	1/8	1-1/2	1/8	1	2-1/2	08834181206
M-7	1/8	1/2	1/4	1-1/4	2-1/4	08834181207
M-8	1/8	3/4	1/4	1-1/4	2-1/2	08834181208
M-9	1/8	1	1/4	1-1/4	2-3/4	08834181209
M-10	1/8	1-1/2	1/4	1-1/4	3-1/4	08834181210
M-11	1/8	2	1/4	1-1/4	4	08834181211
M-12	3/16	1/2	1/8	1-1/4	2-1/4	08834181212
M-13	3/16	3/4	1/8	1-1/4	2-1/2	08834181213
M-14	3/16	1/2	1/4	1-1/4	2-1/2	08834181214
M-15	3/16	3/4	1/4	1-1/4	2-3/4	08834181215
M-16	3/16	1	1/4	1-1/4	3	08834181216
M-17	3/16	1-1/2	1/4	1-1/4	3-1/2	08834181217
M-18	3/16	2	1/4	1-1/4	4	08834181218
M-19	1/4	1/2	1/4	1-1/4	2-1/2	08834181219
M-20	1/4	3/4	1/4	1-1/4	2-3/4	08834181220
M-21	1/4	1	1/4	1-1/4	3	08834181221
M-22	1/4	1-1/2	1/4	1-1/4	3-1/2	08834181222
M-23	1/4	2	1/4	1-1/4	4	08834181223
M-24	5/16	3/4	1/4	1-1/4	2-3/4	08834181224
M-25	5/16	1	1/4	1-1/4	3	08834181225
M-26	5/16	1-1/2	1/4	1-1/4	3-1/2	08834181226
M-27	5/16	2	1/4	1-1/4	4	08834181227

STANDARD PACKAGE = 1

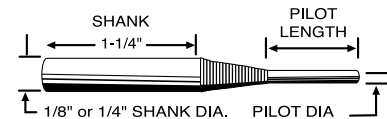

Recommended Pilot Length for Mandrels

3/4 Roll Length	use 1/2 Pilot
1 Roll Length	use 3/4 Pilot
1-1/2 Roll Length	use 1 Pilot
2 Roll Length	use 1-1/2 Pilot

Extra Shank Length Mandrels

MODEL NO.	SHANK LENGTH	OVERALL LENGTH	PART NO.
Extras Shank Length Mandrels			
M-8-4	4	5-1/4	08834180116
M-8-6	6	7-1/4	08834180122
M-9-2.5	2-1/2	4	08834180096
M-9-3	3	4-1/2	08834180129
M-9-4	4	5-1/2	08834180074
M-9-6	6	7-1/2	08834180131
M-9-8	8	9-1/2	08834180133
M-10-4	4	6	08834180092
M-10-6	6	8	08834180145

ALL EXTRA LENGTH SHANKS ARE 1/4" DIAMETER

STANDARD PACKAGE = 1



Tapered Cone Point Mandrels

DESCRIPTION	SHANK	PART NO.
Cone Point Mandrels		
A-10	1/4	08834181300
B-20	1/4	08834181301
C-30	1/4	08834181302
D-40	1/4	08834181303
E-50	A1/4	08834181304
F-60	1/4	08834181305
G-70	1/4	08834181306
H-80	1/4	08834181307
I-90	1/4	08834181308
K-110	1/8	08834181310

STANDARD PACKAGE = 1

Test Kits

Merit Blaze Cartridge Roll Test Kit

- Part No. 66261066726
- Kit includes a variety of our new Merit Blaze cartridge rolls, spiral rolls and mandrels in popular sizes and grits.

Merit Aluminum Oxide Cartridge Roll Test Kit "CR"

- Part No. 08834181061
- Includes over 120 pieces of our most popular sizes, grits and shapes with their appropriate mandrels.

Merit General Purpose Test Kit "GP"

- Part No. 08834169025
- Includes samples of various Merit abrasive specialties. One of these kits could be worth the cost of the entire kit by solving your problems in deburring, polishing and grinding.

Merit Porting Test Kit "APK-MO"

- Part No. 08834169032
- The samples in this kit highlight Merit for general metal and wood working polishing and finishing applications.





CATEGORY DEFINITION

Square pads, cross pads and overlap slotted discs are all used on high speed pneumatic tools for deburring, blending, cleaning, and polishing applications. All of these abrasive specialties are designed for applications in small, tight, hard-to-access locations on parts that are being finished.

- BENEFITS:** Variety of shapes and sizes to fit application and part geometry
 Shapes provide flexibility for the application, while eliminating aggressiveness of the sanding action
 Cross Pads allow visibility of the surface while sanding, to ensure correct amount of material is removed
- GRIT RANGE:** 50 – 180
- ABRASIVE GRAIN:** Ceramic Alumina, Aluminum Oxide
- BACKING:** Cotton
- MAXIMUM RPM:** 1" Diameter – 25,000
 1-1/2" to 2" Diameter – 18,000 to 23,000
 2-1/2" Diameter – 14,000 to 18,000
 3" Diameter – 12,000 to 14,000
 4" Diameter – 8,000 to 12,000
 5" to 6" Diameter – 5,500 to 7,500

APPLICATION/GRIT RECOMMENDATION GUIDE

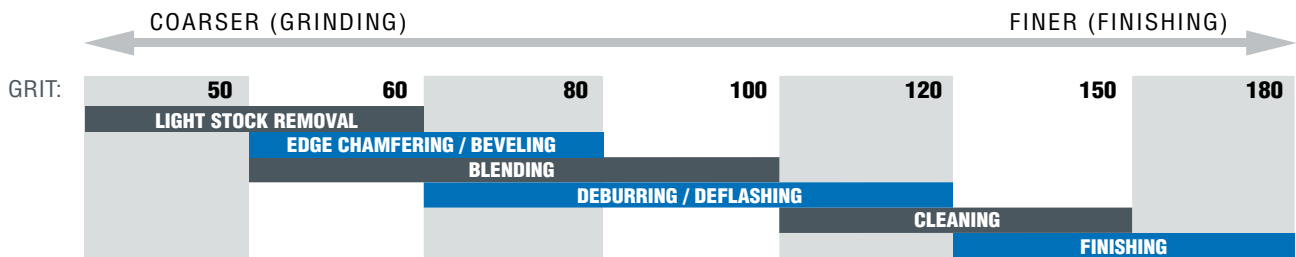

FEATURED PRODUCTS



MERIT BLAZE

BEST FOR HARD-TO-GRIND MATERIALS – STAINLESS STEEL, COBALT, INCONEL, AND TITANIUM

FEATURES

- Next-generation ceramic alumina abrasive grain
- Advanced grinding aid
- Improved resin bond system

BENEFITS

- Significantly faster cut rates
- Resists wear, resulting in 50%-300% longer life
- Greatest productivity
- Cooler cutting, longer life
- Improved grain retention and longer life



MERIT ALUMINUM OXIDE

GOOD FOR MOST ID DEBURRING AND POLISHING APPLICATIONS

FEATURES

- Quality aluminum oxide abrasive grain
- Resin bond system
- Standard quick-change eyelet for easy mounting to quick-change mandrel

BENEFITS

- Versatile; ideal for deburring, chamfering, and polishing most radii, holes, recesses, and cylinder walls
- Good grain retention and life
- Fast, easy mounting and removal; minimal downtime
- Mandrel use increases range and versatility

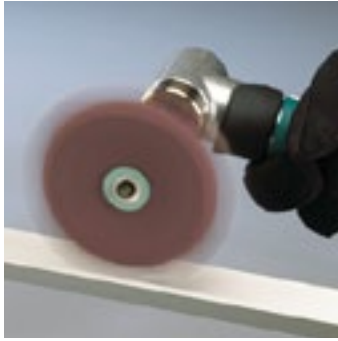

Merit Square Pads

- With Merit square pads, corners wear down consistently exposing fresh abrasive; the pad becomes round for less aggressive stock removal
- Grind almost as fast as hard wheels, but are much smoother and easier to control
- For quick blending of channels, fillets, corners, or spotting flat surfaces

Square Pads

AVAILABILITY

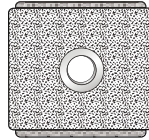

L x W x T	EYELET	GRIT	STD. PKG.	PART NO.	PART NO.
1 x 1 x 6 ply	8-32	80	100		08834184826
1 x 1 x 8 ply	8-32	60	100		08834184828
		80			08834184124
		120			08834184994
1-1/2 x 1-1/2 x 1/2	1/4-20	60	100		08834184463
		80			08834184125
2 x 2 x 1/2	1/4-20	60	100	66261194520	08834184334
		80		66261194552	08834184397
		120		66261194554	
2 x 2 x 3/4	1/4-20	50	100		08834184487
		80			08834184394
3 x 3 x 1/4	1/4-20	60	100	66261194531	
		80		66261194555	08834184882
		120		66261194556	
3 x 3 x 1/2	1/4-20	50	100		08834182152
		60		66261194528	08834182057
		80		66261194557	08834184336
		120		66261194558	



BEST

TIER: Merit Blaze Ceramic Alumina
ABRASIVE: Supersized
OTHER:



GOOD

Merit Aluminum Oxide



Merit Cross Pads

- The shape of Merit's cross pads enables you to see through to the contact area, and provides greater flexibility than square pads to conform to variable internal diameters
- Used for close-tolerance polishing of small radii and channels, deburring, and finishing of bell-mouth configurations
- All pads are furnished with standard quick-change eyelet, as listed
- Plain hole sizes must be specified

Cross Pads

AVAILABILITY

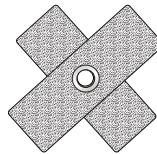

L x W x T	PLY	EYELET	GRIT	STD. PKG.	PART NO.	PART NO.
3/4 x 3/4 x 3/8	8	3-48	80	100		08834185578
1 x 1 x 3/8	8	3-48	60	100		08834184943
			80			08834185519
			100			08834184195
			120			08834185164
1-1/2 x 1-1/2 x 1/2	8	8-32	60	100	66261194496	08834184258
			80		66261194508	08834184465
			100			08834182196
			120		66261194511	08834182148
2 x 2 x 1/2	8	8-32	60	100		08834182156
			80			08834182157
			120			08834182132
2 x 2 x 3/4	8	8-32	60	100	66261194502	08834184128
			80		66261194513	08834184194
			120		66261194516	08834184285
2 x 2 x 1	8	8-32	120	100		08834184805
2-1/4 x 2-1/4 x 1/2	8	8-32	80	100		08834184402
2-1/2 x 2-1/2 x 3/4	8	8-32	80	100		08834184206
			120			08834184074
3 x 3 x 1	8	1/4-20	60	100	66261194504	08834182135
			80		66261194549	08834184119
			120		66261194551	08834184116
3 x 3 x 1	10	1/4-20	80	100		08834182140
3 x 3 x 1-1/2	10	1/4-20	80	100		08834182184
4 x 4 x 1	8	1/4-20	60	100		08834184142
			80			08834184135
			120			08834184377
4 x 4 x 1-1/2	8	1/4-20	80	100		08834184129
			120			08834184370



BEST

TIER: Merit Blaze Ceramic Alumina
ABRASIVE: Supersized
OTHER:



GOOD

Merit Aluminum Oxide

Refer to the back of this section for mandrels.



Overlap Slotted Discs

AVAILABILITY

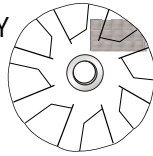

TIER:

BEST

GOOD

GOOD

ABRASIVE:

Merit Blaze
Ceramic Alumina
Supersized, 2-Ply

Merit Aluminum Oxide

Merit Aluminum Oxide

OTHER:

2 Per Set

4 Per Set

DIA.	EYELET	GRIT	STD. PKG.	PART NO.	PART NO.	PART NO.
1	8-32	60	100		08834184346	
		80			08834184019	08834184085
		100			08834184224	
		120			08834184151	08834184236
		180			08834185078	
1-1/4	8-32	60	100		08834184270	
		80			08834184065	
		100			08834184291	
		120			08834184084	
1-1/2	8-32	60	100	66261195051	08834184066	
		80		66261195368	08834184079	
		100			08834184279	08834184023
		120		66261195367	08834186035	
		180			08834184498	
1-3/4	8-32	60	100		08834184655	
		80			08834184042	
2	8-32	60	100	66261195054		
		80		66261195055	08834184076	
		100			08834184145	
		120		66261195056	08834184055	
2-1/2	8-32	80	100		08834184444	
3	1/4-20	50	100		08834184818	
		60			66261195057	08834184041
		80			66261195058	08834184077
		100				08834184082
		120			66261195059	08834184344
4	1/4-20	60	100		08834184000	
		100			08834184159	
		120			08834185155	
					66261029934	
4-1/2	1/4-20	100	100		08834184431	
		120				
5	1/4-20	100	100		08834184302	

ALL OVERLAP SLOTTED DISCS ARE AVAILABLE (MADE-TO-ORDER) REINFORCED WITH A FIBER WASHER

Merit Overlap Slotted Discs

- Used for deburring and polishing radii, holes and cylinder walls
- Our “2 to a set” configuration cuts on the inward motion only
- The “4 to a set” configuration, assembled back to back, cuts on both the inward and outward motions
- All discs are furnished with standard quick-change eyelet
- Plain hole sizes must be specified and are make-to-order

Quick-Change Mandrels for Overlap Slotted Discs, Square and Cross Pads

CROSS PAD SIZE DIA.	SQUARE PAD SIZE DIA.	OAL	MODEL NO.	THD. SIZE	PART NO.
1/4, 3/8, and 1/2 wide		2-1/2	MM48-4	3-48	08834183162
3/4, 1 wide	Up thru 1-1/2 sq. x 1/2 thick 2 sq. x 1/4 or 3/8 thick	3	MM32-4	8-32	08834183163
		4	MM-32-4-4	8-32	08834121680
		6	MM-32-4-6	8-32	08834121681
All pads 2-1/2 x 1-1/2 and larger	2 sq. x 1/4 or 1/2 thick and larger	3	MM20-4	1/4-20	08834183164

FOR OVERLAP SLOTTED DISCS, CHOOSE A MANDREL WITH THE SAME THREAD SIZE AS THE DISC

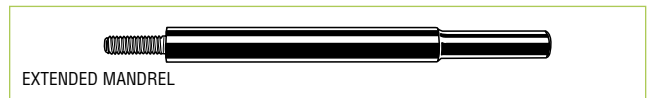
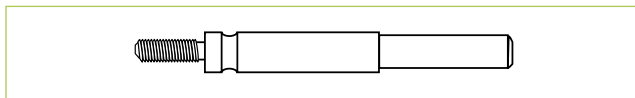

EXTENDED MANDREL



CATEGORY DEFINITION

Flaps of abrasive cloth are stacked, inserted into a holder, and then attached to a mandrel. The flaps are designed to break down during use and reveal the next layer of abrasive.

Cloth flaps are mixed with non-woven flaps to create an interleaf bore polisher.

APPLICATIONS: For deburring, sizing, cleaning and polishing the interior diameters of cylinders, tubes and hydraulic fittings. Flaps adjust automatically to inside diameter, polishing the entire surface area with each pass.





Bore polishers are self-centering, so they apply equal pressure to full wall of inside diameter. Spring action design gives faster inside diameter cleaning, deburring and polishing to cylinders, deep bores and tubes.

Interleafed bore polishers are designed to polish and finish in one easy application. The abrasive flaps cut, while the non-woven flaps apply a fine finish.

GRIT RANGE: 60 - 240

ABRASIVE GRAIN: Aluminum Oxide

APPLICATION-TO-PRODUCT SHAPE RECOMMENDATION GUIDE

SHAPE	APPLICATION
 <p>Bore Polisher Solid Flaps B-3 Series</p>	<ul style="list-style-type: none"> • For 5/8" to 1" interior diameter bores • 3 abrasive packs 1-1/2" wide, bonded to hub • Use with QC-5 mandrel Part No. 08834154182
 <p>Bore Polisher Solid Flaps B-4 Series</p>	<ul style="list-style-type: none"> • For 1" to 4" interior diameter bores • 4 abrasive packs 1-1/2" wide, bonded to hub • Use with BPM-4 mandrel Part No. 08834154183
 <p>Bore Polisher Solid Flaps B-8 Series</p>	<ul style="list-style-type: none"> • For 2" to 5-7/8" interior diameter bores • 8 abrasive packs 1-1/2" wide, bonded to hub • Use with BPM-8 mandrel Part No. 08834154184
 <p>Bore Polisher Scored Flaps</p>	Available upon request
 <p>Bore Polisher Interleaf</p>	Merit interleaf bore polishers do double duty. Designed to polish and finish in one easy application, they are the ideal choice when close tolerances must be maintained, while giving an interior a polished finish.

APPLICATION/GRIT RECOMMENDATION GUIDE

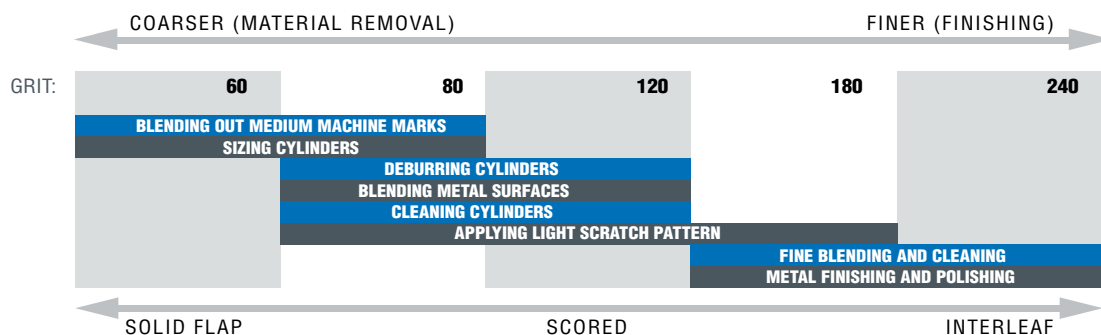



Merit Aluminum Oxide Bore Polishers

AVAILABILITY

TIER:	GOOD
ABRASIVE:	Aluminum Oxide
BACKING:	X-wt. Cotton/Poly

DESCRIPTION	GRIT	MAX. RPM	STD. PKG.	PART NO.
Bore Polishers – Solid Flap B-3 and B-4 Series				
B-305	60	25,000	10	08834154190
Fits I.D. 5/8 to 1	80			08834154191
	120			08834154193
	180			08834154195
	240			08834154197
B-405	60	22,000	10	08834154091
Fits I.D. 1 to 1-1/2	80			08834154092
	120			08834154093
	180			08834154094
	240			08834154100
B-410	60	20,000	10	08834154101
Fits I.D. 1-1/2 to 2	80			08834154102
	120			08834154103
	180			08834154104
	240			08834154109
B-415	60	16,000	10	08834154110
Fits I.D. 2-1/8 to 2-1/2	80			08834154111
	120			08834154112
	180			08834154113
	240			08834154118
B-420	60	15,000	10	08834154119
Fits I.D. 2-1/2 to 3	80			08834154120
	120			08834154121
	180			08834154122
	240			08834154127
B-425	60	10,000	10	08834154128
Fits I.D. 3-1/8 to 4	80			08834154129
	120			08834154130
	180			08834154131
	240			08834154131

STANDARD PACKAGE = 1

TIER:	GOOD
ABRASIVE:	Aluminum Oxide
BACKING:	X-wt. Cotton/Poly

DESCRIPTION	GRIT	MAX. RPM	STD. PKG.	PART NO.
Bore Polishers – Solid Flap B-8 Series				
B-810	60	16,000	10	08834154136
Fits I.D. 2 to 2-1/2	80			08834154137
	120			08834154138
	180			08834154139
	240			08834154140
B-815	60	15,000	10	08834154145
Fits I.D. 2-5/8 to 3	80			08834154146
	120			08834154147
	180			08834154148
	240			08834154149
B-820	60	10,000	10	08834154154
Fits I.D. 3-1/8 to 4	80			08834154155
	120			08834154156
	180			08834154157
	240			08834154158
B-825	60	8,000	10	08834154163
Fits I.D. 4-1/4 to 5-1/4	80			08834154164
	120			08834154165
	180			08834154166
	240			08834154167
B-830	60	8,000	10	08834154172
Fits I.D. 5-1/4 to 5-7/8	80			08834154173
	120			08834154174
	180			08834154175
	240			08834154176

Bore Polishers – Scored Flaps

Available on request

Bore Polishers – Interleaf

B-405 Interleaf	80	22,000	10	08834150271
Fits ID 1 to 1-1/2	180			08834150273
B-410 Interleaf	80	20,000	10	08834150275
Fits ID 1-1/2 to 2				

STANDARD PACKAGE = 1

Mandrels for Bore Polishers

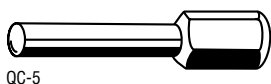

QC-5

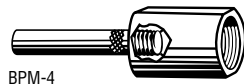

BPM-4



QC-5 EXT



BPM-8

DESCRIPTION	MODEL NO.	THREAD	PART NO.
For B-3 Series	QC-5	5/16-18	08834154182
For B-4 Series	BPM-4	1/2-20	08834154183
For B-8 Series	BPM-8	1/4-20	08834154184
QC-5 Ext.	QC-5 Ext.	5/16-18	08834150573

STANDARD PACKAGE = 1

Extension Mandrels for Bore Polishers

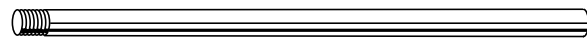

DIAMETER X LENGTH	MODEL NO.	THREAD	PART #
1/4 x 4	EM-144	1/4-20	08834154185
1/4 x 6	EM-146	1/4-20	08834154186
1/4 x 8	EM-148	1/4-20	08834154187

To extend a B-3 series bore polisher, attach the QC-5 Ext. to the bore polisher, then attach the desired length extension mandrel above to the QC-5 Ext. To extend a B-4 series bore polisher, attach the adapter piece of the BPM-4 mandrel to the bore polisher, then attach the desired length extension mandrel above to the BPM-4 adapter piece. To extend a B-8 series bore polisher, attach the desired length extension mandrel above directly to the bore polisher. Standard package = 1.

Test Kit

Merit Bore Polisher Test Kit "BP"

- Part No. 08834154181
- Contains ten bore polishers and two mini 1/4"-20 thread flap wheels in assorted sizes and grits for finishing 1" to 5" interior diameters, and mandrel for 1/4" chuck.







NORTON
SAINT-GOBAIN
BLAZE[®]
RAPID STRIP

NORTON
SAINT-GOBAIN
VORTEX[®]
RAPID BLEND

NORTON
SAINT-GOBAIN
RAPID PREP[™]

NORTON
SAINT-GOBAIN
RAPID FINISH[™]



CATEGORY DEFINITION

Non-woven right angle discs have three components: strong synthetic fiber mesh and quality abrasives, bonded together by a smear-resistant adhesive. Rapid Strip discs have an open web construction that enables aggressive cutting action while inherently maintaining a cool, non-loading surface. Rapid Finish discs have a very tight unitized construction for deburring and finishing. Rapid Prep and Surface Preparation discs have a more open weave that excels in preparation and cleaning of a surface. Each product provides excellent cutting action while improving surface finish.

The non-woven web is attached to a fiberglass backing plate (Rapid Strip/Rapid Finish/Rapid Prep depressed center wheels) for direct mounting or onto a woven substrate backing (Surface Prep discs) for mounting on a rubber back-up pad.

- APPLICATIONS:** Medium-to-light material removal, deburring, blending, cleaning, finishing, and polishing
- SIZE RANGE:** 4-1/2" - 7" / 7/8" plain hole or 5/8"-11 discard mount
- GRIT RANGE:** X-Coarse, Coarse, Medium, Fine, Very Fine
- ABRASIVE GRAIN:** Ceramic Alumina, Silicon Carbide, Aluminum Oxide
- BACKING PLATE:** Fiberglass (Rapid Strip, Rapid Blend and Rapid Prep)
- BACK-UP PAD:** Rubber (Surface Prep)

WHY CHOOSE NON-WOVEN RIGHT ANGLE DISCS?

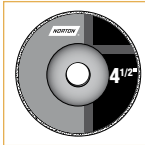
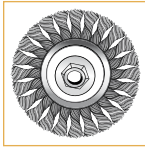
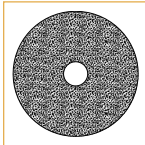
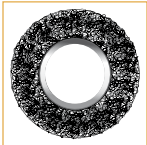

Non-Woven Right Angle Discs vs. Fiber Discs, Wire Wheels, and Depressed Center Wheels

- Deburring, blending and finishing done with one product to reduce the number of steps
- To provide a controlled, sustained finish
- To prevent undercutting and gouging
- To provide a cooler grinding action to lessen the chance of warping or discoloration
- When loading is an issue with fiberglass, adhesives and soft metals
- For stripping coatings and paint off of hard materials like concrete, cement and stone
- Less vibration and quieter for high operator acceptance
- To provide a safe alternative to wire brushes

MATERIAL/APPLICATION-TO-PRODUCT RECOMMENDATION GUIDE

	BEST Highest Productivity. Lowest Total Cost.	BETTER Excellent Blend of Performance & Price.	GOOD Consistent Performance. Low Initial Price.
Removing scale and coarse welding marks	Blaze Rapid Strip Ceramic X/Coarse	–	Rapid Strip S/C X-Coarse, PowerStrip S/C X-Coarse
Removing coatings, epoxy/glue, paint and other clogging material			
Removing rust, oxidation, corrosion and residue			
Removing parting lines and seams on fiberglass parts			
Removing paint/graffiti from concrete/stone			
Removing weld marks and weld splatter	–	Vortex Rapid Blend A/O Coarse	Rapid Blend A/O Coarse
Stainless steel deburring and cleaning			
Removing small flashings and parting lines			
Surface preparation before coatings/plating	–	Vortex Rapid Prep A/O Medium	Rapid Prep A/O Medium
Light cleaning			
Cleaning and prepping welds	–	Vortex Rapid Prep A/O Fine	Rapid Prep A/O Fine
Removing blemishes after welding stainless			
Blending and finishing all metal parts	–	Vortex Rapid Blend A/O Very Fine	Rapid Blend S/C Very Fine
Creating decorative finishes on stainless steel			
Final finishing and polishing			
Final finishing/polishing where high conformability is needed	–	–	Rapid Prep A/O Very Fine

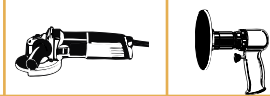

APPLICATION/PRODUCT RECOMMENDATION GUIDE

	← MOST AGGRESSIVE / LEAST CONFORMABLE			LEAST AGGRESSIVE / MOST CONFORMABLE →	
TYPE 27 DISC	BLAZE RAPID STRIP	VORTEX RAPID BLEND MED. RAPID BLEND A/O COARSE	RAPID BLEND A/O MEDIUM	RAPID BLEND S/C FINE	RAPID PREP VERY FINE
DISCS WITH BACK-UP PAD		RAPID PREP A/O COARSE	RAPID PREP A/O MEDIUM	RAPID PREP A/O FINE	
SCALE REMOVAL	BEST CHOICE				
STOCK REMOVAL	BEST CHOICE	SECOND CHOICE			
HEAVY DEBURRING	SECOND CHOICE	BEST CHOICE			
LIGHT DEBURRING		BEST CHOICE	SECOND CHOICE		
LIGHT FINISHING		SECOND CHOICE	BEST CHOICE		
BLENDING			BEST CHOICE	SECOND CHOICE	
FINISHING			SECOND CHOICE	BEST CHOICE	
POLISHING				BEST CHOICE	SECOND CHOICE

CROSS REFERENCE GUIDE

	STRIPPING EXTRA COARSE	SURFACE FINISHING COARSE – MEDIUM – FINE			SURFACE PREP VERY FINE	
	BEST Blaze Rapid Strip	GOOD Rapid Strip	BETTER Vortex Rapid Blend	GOOD Rapid Blend	BETTER Vortex Rapid Prep	GOOD Rapid Prep
NORTON		PowerStrip				Surface Prep
MERIT						
3M	–	Clean & Strip	–	–	–	SL Surface Conditioning
Bibielle	–	SDR Strip-It/Red	–	Unitized	–	–
Camel	–	EZ Strip Black/Red	–	–	–	–
Flexovit	–	Clean & Strip	–	–	–	–
Hermes	–	Webrax	–	–	–	–
Pearl	–	S/C Stripping	–	–	–	Surface Preparation
Pferd	–	Policlean	–	Poliflex PUR	–	–
Sait	–	Sait-Strip	–	Unitized	–	–
Standard	–	Cleaning	–	Unitized	–	–
Superior	–	Stripping	–	Unitized	–	–
Walter	–	FX Cleaning	–	–	–	Blendex Surface Conditioning



Norton Blaze Rapid Strip Type 27 Depressed Center Discs

Strip/blend cast iron, steels, aluminum, fiberglass and composites

- Open structure; will not load on sticky coatings, adhesives, and soft metals (e.g. aluminum), or snag and shed like a cloth or fiber disc
- Norton Blaze ceramic alumina grain provides 2X cut rate and life over silicon carbide
- Will not shed on heavily rust-encrusted pieces
- Extremely versatile; use one disc; stiff enough to stand abuse, but soft enough to prevent gouging and rework
- Use on edge for blending weld root forms
- Apply some pressure to strip-remove coatings; lighter pressure finishes like a surface finishing disc
- Fewer safety, ergonomic, and environmental issues due to fewer change-outs, less downtime, and less production waste/landfill scrap



FEATURED PRODUCTS



NORTON BLAZE RAPID STRIP NON-WOVEN DEPRESSED CENTER DISCS – TYPE 27
BEST CHOICE FOR QUICK AND EASY ROUGH CLEANING AND STRIPPING OF ALL MATERIALS

FEATURES	BENEFITS
■ Blaze ceramic alumina grain	■ 2x cut rate, 2X life over silicon carbide
■ Advanced resin bond	■ Does not shed on rust encrusted pieces, and prevents gouging and rework
	■ Does not snag when used for deburring
■ New coating process	■ Abrasive coating covers the entire disc providing a consistent cut rate
■ Open structure	■ Sticky coating, adhesives and soft metals will not clog the disc

AVAILABILITY

TIER:	BEST	GOOD	GOOD
BRAND:	Norton	Norton	Merit
TRADENAME:	BLAZE RAPID STRIP	RAPID STRIP	POWER STRIP
ABRASIVE:	Ceramic Alumina	Silicon Carbide	Silicon Carbide
GRIT SIZE:	36-50	36-50	36-50
GRADE:	X-Coarse	X-Coarse	X-Coarse
TYPE/BACKING:	Type 27/Fiberglass	Type 27/Fiberglass	Type 27/Fiberglass

SIZE (D x H)	MAX. RPM	STD. PKG.	PART NO.	PART NO.	PART NO.
4-1/2 x 5/8-11	12,000	10	66254498101	66261009585	08834197038
4-1/2 x 7/8	12,000	10	66623303783	66261009649	08834192122
5 x 5/8-11	11,000	10	66623303915		
5 x 7/8	11,000	10	66623303916		
7 x 5/8-11	8,000	10	66623303919	66261009650	08834197040
7 x 7/8	8,000	10	66623303920	66261009586	08834196415



NORTON VORTEX RAPID BLEND DEPRESSED CENTER DISCS – TYPE 27
REVOLUTIONARY TECHNOLOGY FOR HEAVY DEBURRING AND FINISHING

FEATURES	BENEFITS
■ High-performance engineered abrasive	■ Aggressive, fast stock removal cut rate while providing a fine finish
	■ Twice the wheel life over conventional unified wheels, with minimal shedding
■ New bond technology	■ Consistent performance with no smearing
■ Controlled porosity	■ Cooler and improved cut rate

AVAILABILITY

TIER:	BEST	GOOD	GOOD	GOOD	GOOD
BRAND:	Norton	Norton	Norton	Norton	Norton
TRADENAME:	VORTEX RAPID BLEND	RAPID BLEND	RAPID BLEND	RAPID BLEND	RAPID PREP
ABRASIVE:	Engineered A/O	Aluminum Oxide	Aluminum Oxide	Silicon Carbide	Aluminum Oxide
GRIT SIZE:	100-120	150-180	220-280	320-400	150-180
GRADE:	Medium	Medium	Fine	Very Fine	Medium
TYPE/BACKING:	Type 27/Fiberglass	Type 27/Fiberglass	Type 27/Fiberglass	Type 27/Fiberglass	Type 27/Fiberglass

SIZE (D x H)	MAX. RPM	STD. PKG.	PART NO.	PART NO.	PART NO.	PART NO.	PART NO.
4-1/2 x 5/8-11	12,000	10	66254429243	66261023947	66261023946	66261023943	66261023949
4-1/2 x 7/8	12,000	10	66254429268	66261020548	66261020547	66261020546	66261020549

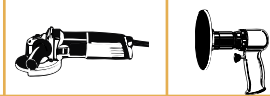

FEATURED PRODUCTS



NEW

NORTON VORTEX RAPID PREP NON-WOVEN DISCS BETTER CHOICE FOR FINISHING AND BLENDING APPLICATIONS

FEATURES

- Proprietary, engineered Vortex aluminum oxide abrasive grain and new coating method

BENEFITS

- Most consistent cutting and finishing of surface conditioning products on the market
- Combine the cutting speed with the finish of fine grits
- Reduce process times by 50+% by eliminating 2 to 5 grit sequences to 1 step in your technical blending operations
- More resistant to edge wear; up 4X life vs. competitive products
- Friable grain structure keeps Ra specs throughout disc life and reduces scrap and rework



AVOS RAPID PREP SPEED-LOK DISCS BETTER CHOICE FOR LIGHT DEBURRING, CLEANING AND FINISHING

FEATURES

- Patented hole design
- Scooped holes
- 15 degree angle back-up pad

BENEFITS

- Allows interrupted cut, reducing heat up to 30% over standard surface preparation discs
- Cool cutting results in longer disc life
- Provides complete vision into the grinding zone
- Operators can grind more accurately with less re-work
- Create air flow to pull loose abrasive and swarf away from work surface grinding zone – resulting in extended disc life
- Grinding at 5°-15° angle allows greater utilization of disc surface
- Eliminates gouging of workpiece

Norton Vortex Rapid Prep

DIA.	7/8"	AVOS SPEED-LOK	SPEED CHANGE 5/8"-11"
EXTRA COARSE			
4-1/2"	66623334973	66623374800	66623373667
5"	66623334975	66623374801	66623373669
6"	66623341359		
7"	66623341360	66623374802	66623373670
COARSE			
4-1/2"	66623334944	66623374803	66623373671
5"	66623334946	66623374804	66623373674
6"	66623341361		
7"	66623341362	66623374805	66623373675
MEDIUM			
4-1/2"	66623333612	66623374806	66623373678
5"	66623334963	66623374807	66623373679
6"	66623341363		
7"	66623341364	66623374808	66623373680
FINE			
4-1/2"	66623333608	66623374809	66623373681
5"	66623334954	66623374810	66623373682
6"	66623341365		
7"	66623341366	66623374811	66623373684
VERY FINE			
4-1/2"	66623333616	66623374812	66623373685
5"	66623333618	66623374813	66623373686
6"	66623341367		
7"	66623341368	66623374814	66623373687

Norton Rapid Prep

DIA.	7/8"	AVOS SPEED-LOK	SPEED CHANGE 5/8"-11"
EXTRA COARSE			
4-1/2"	66623326070	66623374815	66623373690
5"	66261090645	66623374816	66623373691
6"	66623326076		
7"	66623326085	66623374817	66623373692
COARSE			
4-1/2"	66254473868	66261010447	66623373693
5"	66261008293	66623374818	66254498516
6"	66623325136		
7"	66623325138		66261192908
MEDIUM			
4-1/2"	66623325915	66261010448	66623308157
5"	66261017124	66623374819	66623373694
6"	66623325918		
7"	66623325919		66261192913
FINE			
4-1/2"	66623325153	66623374820	66623373696
5"	66254469132	66623374821	66623373695
6"	66623325159		
7"	66623325897	66623374822	66623373697
VERY FINE			
4-1/2"	66623325938	66623374823	66623373698
5"	66623325943	66623374824	66623373699
6"	66623325958		
7"	66623325959		66623373700

Merit Surface Prep

DIA.	7/8"	AVOS SPEED-LOK	SPEED CHANGE 5/8"-11"
EXTRA COARSE			
4-1/2"	66261096871	66623374826	66623373701
5"	66261069521	66623374827	08834164631
6"	66623326083		
7"	66623326086	66623374828	66623373702
COARSE			
4-1/2"	66623325131	66623374829	66261199421
5"	66261070755	66623374830	08834166411
6"	66623325162		
7"	66623325139	66623374831	08834166414
MEDIUM			
4-1/2"	66254491135	66623374832	66623373703
5"	66261070750	66623374833	08834168802
6"	66623325954		
7"	66623325921	66623374834	66261069674
FINE			
4-1/2"	66623325152	66623374835	66623373704
5"	66623325157	66623374836	66623373705
6"	66623325895		
7"	66623325901	66623374837	66623373706
VERY FINE			
4-1/2"	66623325939	66623374838	66254460716
5"	66623325947	66623374839	08834166413
6"	66623326078		
7"	66623325961	66623374840	08834166416

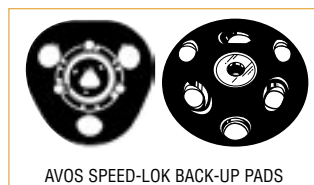

AVOS SPEED-LOK BACK-UP PADS



SPEED-CHANGE BACK-UP PADS

DESCRIPTION	MAX. RPM	STD. PKG.	PART NO.
AVOS Speed-Lok Back-up Pads			
4-1/2" x 5/8-11 (triangular)	13,000	5	63642502985
5 x 3/8-24 Pistol Grip* (triangular)	20,000	5	63642503029
5 x 5/8-11 (triangular)	13,000	5	63642502517
5 x 5/8-11 (triangular)	13,000	5	63642503663
5 x 7/16-20 Pistol Grip* (triangular)	20,000	5	63642503030
7 x 5/8-11 Hard (Round)	8,600	5	63642504873
7 x 5/8-11 Medium (Round)	8,600	5	63642504874

* USE ON AIR PNEUMATIC AND HIGH-SPEED PISTOL GRIP SANDERS.

DESCRIPTION	MAX. RPM	STD. PKG.	PART NO.
Speed-Change Rubber Back-up Pads			
4-1/2" Medium	20,000	5	66254492277
5" Medium	12,000	5	63642543235
7" Hard	8,600	5	63642543240
7" Medium	8,600	5	63642543245
7" Soft	8,600	5	63642543250
9" Medium	7,000	5	63642543270
Surface Prep Disc Back-up Pads			
4-1/2" Medium	11,000	5	63642502122
5" Medium	10,000	5	63642543421
7" Medium	8,600	5	63642543422



CATEGORY DEFINITION

Norton and Merit non-woven discs are a combination of strong synthetic mesh and quality abrasives, bonded together by a smear-resistant adhesive. They are ideal for use on portable tools to clean and remove imperfections on metal surfaces, clean, deburr or finish a variety of surfaces, blend weld seams, or create decorative finishes. The open construction of the non-woven material enables aggressive cutting action and improved surface finish while maintaining its non-loading feature.

- APPLICATIONS:** Medium-light stock removal, beveling, deburring/deflashing, rust removal, blending, cleaning and finishing, polishing
- SURFACE FINISHING MATERIALS:** Surface Stripping, Surface Deburring & Blending, Surface Preparation, Buffing, Felt Polishing
- SIZE RANGE:** 3/4" – 8" diameter
- GRIT RANGE:** X-Coarse, Coarse, Medium, Fine, Very Fine, Super Fine
- ABRASIVE GRAIN:** Ceramic Alumina, Aluminum Oxide, Silicon Carbide
- ATTACHMENT:** Quick-Change Type TR (Type III), Type TS (Type II), and Type TP (Type I), Hook and Loop, and Arbor Hole
- BACK-UP PADS:** Rubber with hardness variations for different applications

QUICK-CHANGE ATTACHMENT SYSTEMS AND CROSS REFERENCE GUIDE

Type TR (Type III)

- Features a roll-on/roll-off style fastener
- Fastener is made of plastic
- Equivalent to 3M™ Roloc™ fastening system

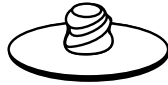

Type TS (Type II)

- Features a turn-on/turn-off style fastener
- Fastener is made of metal
- Equivalent to Standard Abrasives' SocAtt® locking system



Type TP (Type I)

- Snap-on/snap-off system which enables you to change discs quickly and safely, reducing downtime and operating expenses
- Fastener is made of nylon



NORTON

TR

TS

TP

MERIT

Type III

Type II

Type I

3M	Roloc TR	Roloc TS/TSM	Roloc TP
Standard	TR (Lockit)	TS (SocAtt)	TP (ClickOn)
Superior	Type R	Type S	–
Arc	Type R	Type S	Type P
Pferd	Type CDR	Type CD	–
Sait	SAIT-LOK-R	SAIT-LOK	–
Camel	Roll On	Turn On	–
Klingspor	QRC	QMC	–
Garryson	Type R	Type S	–

APPLICATION/GRIT RECOMMENDATION GUIDE

	← MOST AGGRESSIVE		→ LEAST AGGRESSIVE	
NORTON	BLAZE RAPID STRIP	VORTEX RAPID BLEND	RAPID PREP	RAPID PREP
MERIT		DEBURRING & BLENDING	SURFACE PREP	SURFACE PREP HS BUFFING, BUFFING
SCALE REMOVAL	BEST CHOICE			
STOCK REMOVAL	BEST CHOICE	SECOND CHOICE		
HEAVY DEBURRING	SECOND CHOICE	BEST CHOICE		
LIGHT DEBURRING		BEST CHOICE	SECOND CHOICE	
LIGHT FINISHING			BEST CHOICE	SECOND CHOICE
BLENDING			BEST CHOICE	SECOND CHOICE
CLEANING			SECOND CHOICE	BEST CHOICE
FINISHING				BEST CHOICE SECOND CHOICE



CROSS REFERENCE GUIDE

	STRIPPING		HEAVY/LIGHT DEBURRING		LIGHT DEBURRING/BLENDING/CLEANING/FINISHING		
	BEST	GOOD	BETTER	GOOD	BETTER	GOOD	GOOD
NORTON	Blaze Rapid Strip	Rapid Strip	Vortex Rapid Blend	Rapid Blend	Vortex Rapid Prep	Rapid Prep	
MERIT		Power Strip		Deburring & Blending		Surface Prep	HS Buffing, Buffing
3M	-	Clean & Strip Clean Strip XT	-	EXL Unitized	-	Surf Cond, SL, SE	-
Standard	-	Cleaning Disc	-	500-900 Series Unitized	-	FE, GP, RC	Buff & Blend - HS, Buff & Blend
Fiberal/SIA	-		-	-	-	Meteor, Type B & C	-
Superior	-	Type R	-	XL Unitized	-	FD, GD, CC	HS, HD A/O
Arc	-	Arcstrip	-	-	-	Surface Cond	Blend & Finish
Pferd	-	Policlean	-	-	-	Finishing Disc - Hard & Soft	-
Sait	-	SAIT-Strip	-	-	-	HD, GP	Sand-Light Blending
Camel	-	EZ Strip - Black	-	-	-	-	-
Klingspor	-	Strip-It Black	-	-	-	-	-
Garryson	-		-	-	-	Surface Cond	-
Bibielle	-		-	BUR Unitized	-	DCR	-

ABRASIVE/GRIT/DENSITY KEY

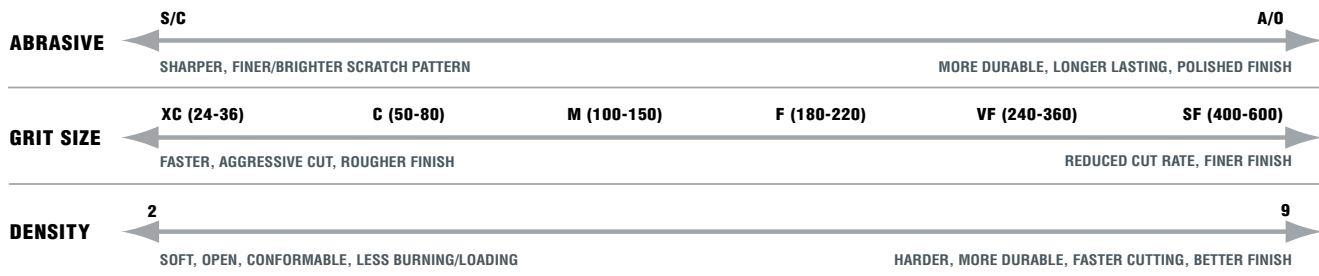

FEATURED PRODUCTS



Quick-Change Rapid Strip Discs

- Rapid Strip material provides a unique combination of aggressive performance, long life and improved finish. It is ideal for removing coatings on a variety of substrates, such as wood, metal and plastics.
- Incorporated with extruded nylon fibers, flexible resin technology, and extra-coarse abrasive grains, these discs outperform traditional coated abrasive products, leaving a thoroughly cleaned surface, which ensures excellent adhesion in subsequent processes such as coating, painting and soldering.
- NEW! Blaze Rapid Strip:** 2X faster cutting as competitive discs; lasts 2X (plus) as long. Stiff enough to stand abuse; soft enough to prevent gouging and rework. Apply some pressure to strip/remove coatings; lighter pressure finishes like a surface finishing disc. Will not load on sticky coatings, adhesives, and soft metals, or snag and shed like a lantuk or fiber disc.

AVAILABILITY

TIER:	BEST
BRAND:	Norton
TRADENAME:	BLAZE RAPID STRIP
ABRASIVE:	Ceramic Alumina
GRADE:	XC
ATTACHMENT:	TR (Type III)



GOOD	GOOD	GOOD	GOOD
Norton	Norton	Merit	Merit
RAPID STRIP	RAPID STRIP	POWER STRIP	POWER STRIP
Silicon Carbide	Silicon Carbide	Silicon Carbide	Silicon Carbide
XC	XC	XC	XC
TR (Type III)	TS (Type II)	TR (Type III)	TS (Type II)



DIAMETER	MAX. RPM	STD. PKG.	PART NO.	STD. PKG.	PART NO.	PART NO.	PART NO.	PART NO.
2 x 1/2	15,500	25	66623303912	10	66261013402	66623333372	08834163514	08834167724
3 x 1/2	12,000	25	66261096557	10	66261013403	66623333374	08834163513	08834167725
4 x 1/2	8,000	5	66623303921	10	66261016580		08834167722	08834167726



FEATURED PRODUCTS

Deburring & Blending Discs



NORTON VORTEX RAPID BLEND DISCS

REVOLUTIONARY TECHNOLOGY FOR HEAVY DEBURRING AND FINISHING

FEATURES

- Proprietary Vortex aluminum oxide aggregate grain
- Special resin chemistry
- New construction: abrasive is distributed throughout the entire disc (top, bottom and side)

BENEFITS

- Performs the medium to fine grit steps of traditional discs in an easy one-step operation
- Resists shedding when used on sharp edges, making it ideal for deburring
- All three faces can be used – versus competitive discs' one bottom layer of abrasive
- 3 - 8 times the life of competitive surface blending discs
- Fewer safety, ergonomic, and environmental issues due to fewer change-outs, less downtime, and less production waste/landfill scrap
- No smearing

AVAILABILITY

TIER:
BRAND::
TRADENAME:
ATTACHMENT:

BETTER	GOOD	GOOD
Norton	Norton	Merit
VORTEX RAPID BLEND	RAPID BLEND	DEBURR/BLEND
TR (Type III)	TR (Type III)	TR (Type III)

SIZE (D x T)	ABR.	GRIT	DENSITY	MAX.RPM	STD. PKG.	PART NO.	PART NO.	PART NO.
2 x 1/8	A/O	C	7-9	22,000	60	66254425632 66254433509	66261014921	
	A/O	M	2-3	22,000	60		66261014897	
	A/O	M	4-6	22,000	60		66261014911	
	A/O	M	7-9	22,000	60		66261014935	
	S/C	F	2	22,000	60		66261014889	
	S/C	F	3	22,000	60		66261017306	
	S/C	F	4-6	22,000	60		66261014906	
2 x 3/16	A/O	M	2-3	22,000	60	66254428236		
2 x 1/4	A/O	C	7-9	22,000	60	66254428237 66254413660 66254433510		66261054187
	A/O	M	1	22,100	25			
	A/O	M	2-3	22,000	60			66261054183
	A/O	M	4-6	22,000	60			66261054185
	A/O	M	7-9	22,000	60			66261054186
	S/C	F	2-3	22,000	60			66261054182
	S/C	F	4-6	22,000	60			66261054184
3 x 1/8	A/O	C	7-9	15,000	40	66261093556 66261090909	66261014922	
	A/O	M	2-3	15,000	40		66261014898	
	A/O	M	4-6	15,000	40		66261014912	66261054191
	A/O	M	7-9	15,000	40		66261014936	
	A/O	F	2-3	15,000	40			66261054188
	A/O	F	4	15,000	40		66261015419	66261054189
	A/O	F	6	15,000	40			66261054190
3 x 3/16	A/O	M	7-9	15,000	40	66254428239		
3 x 1/4	A/O	C	7-9	15,000	40	66254428238 66254413661 66254406395		66261054198*
	A/O	M	1	18,100	25			
	A/O	M	2-3	15,000	40			66261054193*
	A/O	M	4-6	15,000	40			66261054196*
	A/O	M	7-9	15,000	40			66261054197*
	A/O	F	2-3	15,000	40			66261054192*
	A/O	F	4-6	15,000	40			66261054194*
	S/C	F	2	15,000	40			
	S/C	F	3	15,000	40			66261014890
	S/C	F	4-6	15,000	40			66261016005
								66261054195*

STD. PKG. = 20 DISCS

Refer to the end of this section for a list of quick-change back-up pads.



FEATURED PRODUCTS

Surface Preparation Discs



NEW

NORTON VORTEX RAPID PREP
BETTER CHOICE FOR FINISHING AND BLENDING APPLICATIONS

FEATURES	BENEFITS
<ul style="list-style-type: none"> Proprietary Vortex aluminum oxide abrasive grain and new coating method New resin system, aerospace-tailored Extended form holding 	<ul style="list-style-type: none"> Most consistent cutting and finishing of surface conditioning products on the market Combines fast cutting speed with the finish of finer grits Reduce process times by 50+% by combining multiple grit sequences to 1 step in a blending operation More resistant to edge wear; up 4X life vs. competitive products Friable grain structure keeps Ra specs throughout disc life and reduces scrap and rework Smear-free, even on high nickel content alloys Will not load on aluminum and soft metals, as competitive products may Lowest total cost of consumable tooling per workpiece



NORTON RAPID PREP
GOOD CHOICE FOR FINISHING AND BLENDING APPLICATIONS

FEATURES	BENEFITS
<ul style="list-style-type: none"> New resin system, aerospace-tailored Proprietary new coating method 	<ul style="list-style-type: none"> Smear-free, even on high nickel content alloys Will not load on aluminum and soft metals, as competitive products may Thick layer of grain throughout the product extends life; grain does not sit on top of fibers as other competitive products may

Norton Vortex Rapid Prep

DIA.	TR (TYPE III)	TS (TYPE II)	TP (TYPE I)
EXTRA COARSE			
3/4"	66623325001	66623335324	66623325000
1"	66623325004	66623325003	66623325002
1-1/2"	66623325007	66623325006	66623325005
2"	66623335326	66623335325	66623325008
3"	66623335327	66623325010	66623325009
4"	66623335329	66623335328	66623325011
COARSE			
3/4"	66623325013	66623335410	66623325012
1"	66623325015	66623335537	66623325014
1-1/2"	66623335411	66623325017	66623325016
2"	66623335414	66623335413	66623335412
3"	66623335417	66623335416	66623335415
4"	66623335419	66623335418	66623325018
MEDIUM			
3/4"	66623325020	66623335420	66623325019
1"	66623335422	66623335421	66623325021
1-1/2"	66623335424	66623335423	66623325022
2"	66623335427	66623335426	66623335425
3"	66623335430	66623335429	66623335428
4"	66623335432	66623335431	66623325023
FINE			
3/4"	66623325026	66623325025	66623325024
1"	66623325029	66623325028	66623325027
1-1/2"	66623325032	66623325031	66623325030
2"	66623325035	66623325034	66623325033
3"	66623325038	66623325037	66623325036
4"	66623325041	66623325040	66623325039
VERY FINE			
3/4"	66623325044	66623325043	66623325042
1"	66623325047	66623325046	66623325045
1-1/2"	66623325050	66623325049	66623325048
2"	66623335433	66623325052	66623325051
3"	66623335437	66623335436	66623325053
4"	66623325056	66623325055	66623325054

Norton Rapid Prep

DIA.	TR (TYPE III)	TS (TYPE II)	TP (TYPE I)
EXTRA COARSE			
3/4"	66623340002	66261022401	66623340000
1"	66623340007	66623340006	66623340004
1-1/2"	66623340011	66623340010	66623340008
2"	66261016373	66261017819	66623340012
3"	66261016994	66261017818	66623340015
4"	66261016374	66623310706	66623340018
COARSE			
3/4"	66623340021	66261095015	66623340020
1"	66623340023	66261024310	66623340022
1-1/2"	66261047579	66623340026	66623340024
2"	66261009191	66261009183	66254498593
3"	66261009194	66261009186	66254498596
4"	66261008822	66261055349	66623340030
MEDIUM			
3/4"	66623340032	66254428059	66623340031
1"	66254482331	66254482327	66623340033
1-1/2"	66254482332	66254482328	66623340034
2"	66261009190	66261009182	66254498520
3"	66261017522	66261009185	66254498595
4"	66261008821	66261055350	66623340039
FINE			
3/4"	66623340058	66623340056	66623340054
1"	66623340064	66623340062	66623340060
1-1/2"	66623340070	66623340068	66623340066
2"	66623340077	66623340074	66623340072
3"	66623340085	66623340082	66623340080
4"	66623340092	66623340090	66623340088
VERY FINE			
3/4"	66623340044	66623340042	66623340041
1"	66254482339	66254482335	66623340045
1-1/2"	66254482340	66254482336	66623340046
2"	66261009189	66254482337	66254498594
3"	66261009192	66261009184	66254498597
4"	66623340053	66623340052	66623340051
SUPER FINE			
2"	66261091459	66623373996	66623373995
3"	66261091460	66623374001	66623373999

Merit Surface Prep

DIA.	TR (TYPE III)	TS (TYPE II)	TP (TYPE I)
EXTRA COARSE			
3/4"	66623340003	66254449283	66623340001
1"	08834168190	66254449284	66623340005
1-1/2"	08834168156	66261090621	66623340009
2"	08834167825	08834167821	08834168276
3"	08834167827	08834167823	08834162425
4"	08834168289	08834168804	66623340019
COARSE			
3/4"	08834166242	66261026669	08834163845
1"	08834166248	08834166474	08834167170
1-1/2"	08834163540	08834166407	66623340025
2"	66623340028	08834166287	08834163039
3"	08834166322	08834166319	08834166275
4"	08834166327	08834166388	08834166442
MEDIUM			
3/4"	08834166241	66261022000	08834166235
1"	69957351584	66254449282	08834164818
1-1/2"	66623340036	66623340035	08834163049
2"	08834166290	66623340037	08834168277
3"	08834166291	08834162910	08834161024
4"	08834166328	66623340040	08834166299
FINE			
3/4"	66623340059	66623340057	66623340055
1"	66623340065	66623340063	66623340061
1-1/2"	66623340071	66623340069	66623340067
2"	66623340079	66623340075	66623340073
3"	66623340086	66623340083	66623340081
4"	66623340093	66623340091	66623340089
VERY FINE			
3/4"	08834166240	66623340043	08834166234
1"	08834160754	08834166476	08834166243
1-1/2"	08834166367	66623340047	08834166336
2"	66623340049	08834166317	08834166273
3"	66254441300	08834166321	08834166277
4"	08834162686	08834166390	08834166300
SUPER FINE			
2"	66254441623	66623374000	66261092243
3"	66261193683	66623373998	66623303836



FEATURED PRODUCTS



Surface Preparation Stars

- The perfect item for I.D. work
- Their shape penetrates the I.D. and polishes or cleans the surface without disturbing any tolerances
- Attach their 1/4-20 eyelets to Merit's MM20-4 mandrel. Part No. 08834183164 (See description at end of Overlap Slotted Disc Section.)



Buffing/Polishing Discs

Merit Buffing Discs

- Tough, yet conformable, high-strength discs are smear-proof and resist tearing on burrs and sharp edges
- Designed for light removal of paint or rust without affecting the base product

AVAILABILITY

TIER:	GOOD
BRAND::	Merit
TRADENAME:	SURFACE PREP
ABRASIVE:	A/O
ATTACHMENT:	1/4-20

SIZE (D x EYELET)	GRIT	STD. PKG.	PART NO.
1-1/2" x 1/4-20	C	100	08834185923
	M		08834185924
	VF		08834185925
2" x 1/4-20	C	100	08834185926
	M		08834185927
	VF		08834485928
3" x 1/4-20	C	100	08834185929
	M		08834185678
	VF		08834185931
4" x 1/4-20	C	100	08834185932
	M		08834185933
	VF		08834185934

TIER:	BETTER	BETTER	GOOD	GOOD	GOOD
BRAND::	Merit	Merit	Merit	Merit	Merit
TRADENAME:	HIGH-STRENGTH	HIGH-STRENGTH	BUFFING	BUFFING	BUFFING
ABRASIVE:	A/O	A/O	A/O	A/O	A/O
ATTACHMENT:	TR (Type III)	TS (Type II)	TR (Type III)	TS (Type II)	TP (Type I)



SIZE (D)	GRIT	STD. PKG.	PART NO.	PART NO.	PART NO.	PART NO.	PART NO.
1-1/2"	C	100			08834161647	08834166391	08834166294
	M				08834166368	08834166392	08834166292
	F				08834166369	08834166393	08834166332
	VF				08834166417	08834166406	08834166333
2"	C	50			08834161649	08834166394	08834161627
	M		08834164064	08834164244	08834166303	08834166395	08834166280
	F				08834166304	08834166396	08834166281
	VF		08834163987	08834164245	08834166305	08834166405	08834166282
3"	C	25			08834161651	08834166397	08834166293
	M		08834164065	08834164252	08834166308	08834166398	08834166284
	F				08834166309	08834166399	08834166285
	VF		08834163559	08834164255	08834166310	08834166403	08834166286
4"	C	25			08834161654	08834166400	
	M				08834166314	08834166401	08834166295
	F				08834166315	08834166402	08834166296
	VF				08834166316	08834166404	08834166297

Quick-Change Back-up Pads

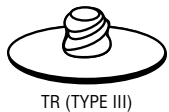

TR (TYPE III)



TS (TYPE II)



TP (TYPE I)

- Hard density pads are for aggressive cutting action
- Medium density pads are for all-purpose applications
- Soft density pads are used for contours and fine finishing work

Refer to the end of the Coated Abrasive Quick-Change Discs section for a complete list of back-up pads and mandrels.

DIAMETER	MAX. RPM	DENSITY	TR (TYPE III)	TS (TYPE II)	TP (TYPE I)
Quick-Change Back-up Pads					
3/4"	40,000	Medium	08834164038	08834164206	08834164001
1"	40,000	Medium	08834164037	08834164651	08834164002
1-1/2"	30,000	Hard	08834164640	08834164622	08834163996
		Medium	08834161174	08834164146	08834164003
2"	30,000	Hard	08834164643	08834164624	08834163997
		Medium	08834164922	08834164198	08834164004
		Soft	08834164641	08834161625	08834163949
3"	20,000	Hard	08834164036	08834161626	08834163998
		Medium	08834164949	08834164113	08834164005
		Soft	08834164644	08834164626	08834163948
4"	15,000	Medium	08834164655	08834164135	08834164006

ALL QUICK-CHANGE BACK-UP PADS HAVE A 1/4" DIAMETER SHANK. STD. PKG. = 1



FEATURED PRODUCTS

Non-Woven Hook and Loop Discs



NEW

NORTON VORTEX RAPID PREP

BETTER CHOICE FOR FINISHING AND BLENDING APPLICATIONS

FEATURES

- Proprietary Vortex aluminum oxide abrasive grain and new coating method
- Improved hook and loop backing

BENEFITS

- Most consistent cutting and finishing of surface conditioning products on the market
- Combines fast cutting speed with the finish of finer grits
- Reduce process times by 50+% by combining multiple grit sequences to 1 step in a blending operation
- More resistant to edge wear; up 4X life vs. competitive products
- Friable grain structure keeps Ra specs throughout disc life and reduces scrap and rework
- Will not fly off rotary sanders
- Discs sit flatter on back-up pads, resulting in a more consistent finish on DA applications

Norton Vortex Rapid Prep

DIA.	HOOK & LOOP
EXTRA COARSE	
1-1/2"	66623325061
2"	66623334970
3"	66623333620
4"	66623334971
4-1/2"	66623334972
5"	66623334974
6"	66623333621
7"	66623334976
8"	66623334977
COARSE	
1-1/2"	66623325057
2"	66623334882
3"	66623334883
4"	66623334884
4-1/2"	66623334943
5"	66623334945
6"	66623334949
7"	66623334951
8"	66623334953
MEDIUM	
1-1/2"	66623325059
2"	66623334958
3"	66623334956
4"	66623334959
4-1/2"	66623334961
5"	66623334962
6"	66623334964
7"	66623334965
8"	66623334966
FINE	
1-1/2"	66623325058
2"	66623333604
3"	66623333605
4"	66623333606
4-1/2"	66623333607
5"	66623333609
6"	66623333610
7"	66623334955
8"	66623333611
VERY FINE	
1-1/2"	66623325060
2"	66623333613
3"	66623333614
4"	66623334967
4-1/2"	66623333615
5"	66623333617
6"	66623334968
7"	66623334969
8"	66623333619

Norton Rapid Prep

DIA.	HOOK & LOOP
EXTRA COARSE	
1-1/2"	66623340098
2"	66261017900
3"	66623326059
4"	66261017382
4-1/2"	66261017906
5"	66261017215
6"	66623326077
7"	66261192846
8"	66261017531
COARSE	
1-1/2"	66623340099
2"	66261004431
3"	66261055015
4"	66261055018
4-1/2"	66261017806
5"	66261004435
6"	66261006910
7"	66261055027
8"	66261006913
MEDIUM	
1-1/2"	66623338571
2"	66261004441
3"	66261004442
4"	66261055019
4-1/2"	66261004444
5"	66261055022
6"	66261006911
7"	66261017813
8"	66261017815
FINE	
1-1/2"	66623340101
2"	66623325141
3"	66623325143
4"	66623325145
4-1/2"	66623325147
5"	66623325154
6"	66623325160
7"	66261199465
8"	66623325907
VERY FINE	
1-1/2"	66623340100
2"	66623325926
3"	66623325934
4"	66261055020
4-1/2"	66623325936
5"	66623325941
6"	66261055026
7"	66261019990
8"	66623325972
SUPER FINE	
4-1/2"	66261094948
5"	66261019962
7"	66261094949

Merit Surface Prep

DIA.	HOOK & LOOP
EXTRA COARSE	
1-1/2"	66623340094
2"	66623325974
3"	66623326060
4"	66623326062
4-1/2"	66623326067
5"	66623326072
6"	66623326084
7"	08834167644
8"	08834163834
COARSE	
1-1/2"	66623340095
2"	05539562621
3"	66623325128
4"	05539512515
4-1/2"	05539520420
5"	05539512519
6"	05539512522
7"	05539512525
8"	05539562627
MEDIUM	
1-1/2"	08834168008
2"	05539562620
3"	05539562623
4"	05539512514
4-1/2"	05539520419
5"	05539512518
6"	05539512521
7"	05539512524
8"	05539562626
FINE	
1-1/2"	66623340097
2"	66623325142
3"	66623325144
4"	66623325146
4-1/2"	66623325148
5"	66623325155
6"	66623325896
7"	66623325898
8"	66623325911
VERY FINE	
1-1/2"	66623340096
2"	66623325929
3"	08834162565
4"	66623325935
4-1/2"	08834162550
5"	08834162584
6"	08834162587
7"	08834162588
8"	66623325973
SUPER FINE	
4-1/2"	66261191633
7"	66261191673

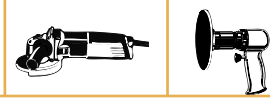

FEATURED PRODUCTS



Back-Up Pads for Hook And Loop Discs

TIER:	GOOD	GOOD
BRAND:	Norton	Merit
TRADENAME:	RAPID PREP	SURFACE PREP

PAD DIAMETER	SPINDLE OR HOLE SIZE	MAX. RPM	3M EQUIVALENT	STD. PKG.	PART NO.	PART NO.
Back-Up Pads for Hook And Loop Discs						
2	1/4 Steel Shank	23,000	922	5	66261059352	08834168025*
3	1/4 Steel Shank	20,000	923	5	66261059354	08834168026*
4	1/4 Steel Shank	18,000	924	5	66261059356	08834168027*
	1/2-13	13,000	914	5	66261059303	05539562714
	5/8-11	13,000	914	5	66261059304	08834168984*
4-1/2	M10 x 1.250	13,000		5	66261059305	
	5/8-11	10,000	9145	5	66261006948	05539562718
5	5/16-24 Male	10,000	905	5	66261059360	08834168993**
	3/8-24 Male	10,000	905	5	66261059308	08834168028*
	5/8-11	10,000	915	5	66261059310	08834168967*
6	5/8-11	8,000	916	5	66261059312	05539562723
7	5/8-11	6,000	917	5	66261059368	08834168032*
8	5/8-11	4,500	918	5	66261059372	

* = 1 PER PKG, ** = 2 PER STD PKG.

Non-Woven High Strength Discs



HIGH STRENGTH AND FASTCUT DISCS
BETTER CHOICE FOR LIGHT DEBURRING AND FINISHING

FEATURES	BENEFITS
■ Firm, durable web	■ High resistance to tearing on burrs and sharp edges
■ Tough, yet conformable	■ Can be "ganged" together and used as a wheel
■ Strong, smear-proof resin binders	■ Produce light satin finishes

Applications include rust/oxide or coating removal, pipe ID and OD polishing, casting cleaning, highlighting (antiquing), contaminant removal, removal of handling marks, gasket removal, cleaning and blending of surface imperfections, prepping prior to soldering, removal of filling materials, cleaning angles and odd shapes

AVAILABILITY

TIER:	BETTER
BRAND:	Norton
TRADENAME:	HIGH STRENGTH
ABRASIVE:	Aluminum Oxide

SIZE (D x H)	ABRASIVE	GRIT	MAX. RPM	STD. PKG.	PART NO.
6 x 1/4	A/O	VF	4,000	70	66261007628
6 x 1/2	A/O	M	4,000	70	66261005073
	A/O	VF			66261004980
8 x 1/2	A/O	M	3,000	50	66261005491
	A/O	VF			66261004506
12 x 1-1/4	A/O	VF	1,900	25	66261008723



FITS HOLE	FOR DISC WIDTH	FOR DISC DIAMETER	SHANK DIAMETER	OVERALL LENGTH	WASHER DIAMETER	STD. PKG.	PART NO.
Mandrel Assemblies for using Discs on Edge							
1/4"	1/2" (Standard)	up to 6"	1/4"	2-1/2"	1-1/2"	1	66261009502
1/2"	1/2" (Standard)	Up to 8"	1/4"	3-1/8"	2-1/4"	1	66261059420





FEATURED PRODUCTS

Non-Woven Abrasive Brushes



NON-WOVEN ABRASIVE BRUSHES – TYPE 27

USE WHERE MAXIMUM CONFORMABILITY IS NEEDED

FEATURES

- Feature tough, flexible nylon filaments embedded with abrasive grain

BENEFITS

- Provide finishing and polishing where maximum conformability is needed



BACK-UP PAD

AVAILABILITY

	GOOD	GOOD
TIER:	GOOD	GOOD
BRAND:	Norton	Norton
TRADENAME:	ABRASIVE BRUSH	ABRASIVE BRUSH
ABRASIVE:	Silicon Carbide	Silicon Carbide
GRIT SIZE:	80	120
GRADE:	Fine	Very Fine
BACKUP-PAD:	Rubber Back-up Pad	Rubber Back-up Pad

SIZE (D x H)	MAX. RPM	STD. PKG.	PART NO.	PART NO.
Abrasive Brush				
7 x 1 x 7/8	6,000	5	66261058830	66261058834
USE WITH AIR-COOLED RUBBER BACK-UP PAD AND RETAINER NUT				
Surface Prep Disc and Abrasive Brush Back-up Pads				
7" Medium	8,600	5	63642543422	



CATEGORY DEFINITION

Surface finishing hand pads and rolls are made of a non-woven nylon web impregnated with abrasive grain and resin bond.

- APPLICATIONS:** Light- to heavy-duty cleaning, deburring, blending, polishing, and finishing of metal, wood, composite, plastics, stone, solid surface and painted surfaces.
- ABRASIVE GRAIN:** Aluminum Oxide, Silicon Carbide
- GRIT RANGE:** Coarse (C), Medium (M), Fine (F), Very Fine (VF), Ultra Fine (UF), Micro Fine (MF), Non-Abrasive (-)
- HAND PAD FEATURES:**
- Flexible; conform to work surface
 - Gentle action easily removes flashing or burrs without affecting dimension of workpiece
 - Non-loading; constant supply of new cutting edges
 - Non-rusting; no workpiece contamination
 - Resilient construction; long life, increased productivity; solvent resistant; waterproof
- SPONGE PAD FEATURES:**
- Non-woven material is laminated to a long-lasting sponge for the convenience of 2 pads in one
 - Superior replacement for steel wool
- ROLL FEATURES:**
- Economical alternative to cut pads
 - Can be cut to specific sizes

APPLICATION/GRIT RECOMMENDATION GUIDE

← MORE AGGRESSIVE, ROUGHER FINISH

LESS AGGRESSIVE, FINER FINISH →

PRODUCT #:
COLOR:
DESCRIPTION:
ABRASIVE:
GRIT SIZE:
STEEL WOOL EQUIVALENT:
APPLICATIONS:

	#740 (DARK TAN) HEAVY DUTY	#746 (GRAY) BLENDING	#644 (MAROON) GP - FINE	#747 (MAROON) GP PLUS - VERY FINE	#796 (GREEN) SCOURING	#635 (GRAY) CLEAN & FINISH	#748 (GRAY) FINAL SHINE	#914 (GOLD) CLEAR BLEND PREP	#456 (WHITE) CLEANING
ABRASIVE:	AO	SC	AO	AO	AO	SC	SC	AO	Non-Abrasive
GRIT SIZE:	Medium 100 - 150	Medium 100 - 150	Fine 180 - 220	Very Fine 240 - 360	Very Fine 240 - 360	Ultra Fine 400 - 600	Micro Fine 800 - 1200	Micro Fine 800 - 1200	Non-Abrasive ----
STEEL WOOL EQUIVALENT:	4 Extra Coarse	3 Coarse	2 Medium Coarse	1 Medium	0 Fine	00 Very Fine	00 Very Fine	000 Extra Fine	0000 SuperFine
APPLICATIONS:	<ul style="list-style-type: none"> • Most durable and aggressive cutting pad • Heavy-duty removal <ul style="list-style-type: none"> - rust - oxidation • Deburring 	<ul style="list-style-type: none"> • Blending and deburring <ul style="list-style-type: none"> - welds - aluminum - stainless 	<ul style="list-style-type: none"> • Cleaning and deburring <ul style="list-style-type: none"> - machinery - metal parts - plastic - solid surface - stone 	<ul style="list-style-type: none"> • Light cleaning, deburring and finishing <ul style="list-style-type: none"> - machinery - metal parts - plastic - solid surface - stone 	<ul style="list-style-type: none"> • Removing stains, marks, rust, corrosion or oxidation from stainless equipment • Light cleaning of metal surfaces 	<ul style="list-style-type: none"> • Light cleaning and finishing of most surfaces <ul style="list-style-type: none"> - steel, aluminum - denibbing plastic - scuffing acrylics 	<ul style="list-style-type: none"> • Final finishing <ul style="list-style-type: none"> - final rub on wood - final blend metal - final finish plastics and acrylics 	<ul style="list-style-type: none"> • Scuffing prior to clear coat blending • Ideal for top coat rubbing, sealer sanding prior to lacquer, and defuzzing or denibbing wood • Polishing, blemish repair and finishing all materials 	<ul style="list-style-type: none"> • Scratch-free cleaning <ul style="list-style-type: none"> - metal - fiberglass - stone - solid surface - ceramic • Wood <ul style="list-style-type: none"> - highlighting - rubbing

CROSS REFERENCE GUIDE

← COARSER

FINER →

	#740	#746	#644	#747	#796	#635	#748	#914	#456
NORTON/MERIT									
3M	7440	7446	64659	7447/8447 Production Hand Pad	96	64660	7448		7445
Camel	Tan	-	-	Maroon	Green	-	Grey	-	White
Mirka	-	-	-	Maroon/Red VF	-	-	-	-	-
Sait	Brown	-	-	Maroon	Green	-	Gray	-	-
SIA	6912 Brown	6712 Grey	-	6912 Maroon	6312 Green	-	-	-	-
Standard	HD-Tan AO	-	-	GP-Maroon VF	Green-AO	HP-VF	UF Gray	-	Cleaning White



AVAILABILITY

SIZE (W x L)	COLOR	DESCRIPTION	ABRASIVE	GRIT SIZE	STD. PKG.	TIER:	BETTER	GOOD	GOOD
						BRAND::	Norton	Norton	Merit
						PART NO.	PART NO.	PART NO.	PART NO.
Hand Pads									
6 x 9	Dark Tan	740 Heavy-Duty Pad	A/O	Med	20			66261074000	08834193462
	Gray	746 Blending Pad	S/C	Med	20			66261074600	
	Maroon	777 General Purpose Very Fine Pad	A/O	VF	20			66261077700	08834193463
	Maroon	747 General Purpose Plus Pad	A/O	VF	20	66261074700			08834196204
	Maroon	747 General Purpose Plus Perforated Pad	A/O	VF	20	66261084700			
	Green	796 Scouring Pad	A/O	VF	20			66261079600	08834193497
	Lt. Green	696 Food Pro Pad	A/O	VF	20			66261069600	
	Gray	851 General Cleaning Pad	S/C	VF	20			66261085100	
	Gray	635 Clean & Finish Pad	S/C	UF	20			66261063500	
	Gray	748 Final Shine Pad	S/C	MF	20			66261074800	08834196196
White	456 Cleaning Pad	None	-	20			66261045600	08834193270	
Hand Pad Holder									
3-1/4 x 5-1/2	N/A	Hand Pad Holder			10			66261047583	08834190748
Rolls									
4" x 30 Ft.	Maroon	High Strength Roll	A/O	M	3	66261006358			
	Dark Tan	740 Heavy-Duty Roll	A/O	M	3			66261010081	
	Maroon	644 General Purpose Fine Roll	A/O	F	4			66261058364	05539511952
	Maroon	777 General Purpose Very Fine Roll	A/O	VF	4	66261006373		66261058361	05539526809
	Maroon	747 General Purpose Plus Roll	A/O	VF	4	66261051701			05539562608
	Green	796 Scouring Roll	A/O	VF	5				05539562607
	Gray	851 General Cleaning Roll	S/C	VF	3			66261058360	05539515708
	Gray	635 Clean & Finish Roll	S/C	UF	5			66261058357	05539512500
	White	456 Cleaning Roll	None	-	3			66261052235	05539512839
	6" x 30 Ft.	Maroon	High Strength Roll	A/O	M	2	66261005182		
Maroon		747 General Purpose Plus Roll	A/O	VF	3	66261016430			05539512505
Maroon		777 General Purpose Very Fine Roll	A/O	VF	3	66261004281		66261058376	05539526424
Gray		851 General Cleaning Roll	S/C	VF	3			66261058377	05539562610
Gray		635 Clean & Finish Roll	S/C	UF	3				05539512503
Scouring Pads/Sponges									
3-1/4 x 6-1/4 x 3/4	Green/Yellow	893 Scour-N-Sponge Pad	A/O	VF	40			66261059403	
3-1/4 x 6-1/4 x 3/4	White/Yellow	875 Clean-N-Sponge Pad	None	-	40			66261059402	

Handy Roll Pack Assortment



- Non-woven rolls may be cut for use in hand sanding applications
- Convenient dispenser box containing three 2" x 15 foot long rolls

Norton

- Part No. 66261008108 contains one each of A/O Fine, A/O VF, and SC Micro Fine

Merit

- Part No. 05539562611 contains one each of A/O Fine, A/O VF, SC Ultra Fine



Hand Pad Test Kit

Norton

- Part No. 66254494733
- Non-woven pads are used in applications ranging from stripping and blending to cleaning and polishing
- Hand Pad Test Kit provides one of each of the 14 different materials along with the recommendation guide to help determine which pads you need for all your applications

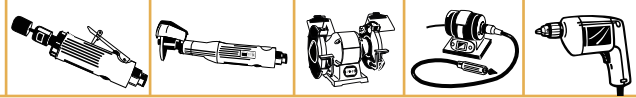

CATEGORY DEFINITION

Made from non-woven synthetic fiber mesh, which is impregnated with abrasives and bound with resins, non-woven wheels are designed to create desired surface finish where little or no stock removal is required. The industry's broadest offer is available for light stock removal, deburring, blending, finishing and polishing.

Non-woven wheels have an open mesh construction that is waterproof, washable, conformable and non-loading.

APPLICATIONS: Clean and remove imperfections on metal surfaces, clean built-up residue, deburr or finish a variety of surfaces, blend weld seams or create decorative finishes. Non-woven surface finishing products have excellent versatility.

ABRASIVE GRAIN: Aluminum Oxide, Silicon Carbide

GRIT RANGE: Extra Coarse (XC), Coarse (C), Medium (M), Very Fine (VF),



APPLICATION/GRIT RECOMMENDATION GUIDE

	MOST AGGRESSIVE → ← LEAST AGGRESSIVE						
	RAPID STRIP	VORTEX & NEX UNIFIED WHEELS	SERIES 4000 & 1000 CONVOLUTE WHEELS	METAL FINISHING CONVOLUTE WHEELS	CLEAN & FINISH WHEELS	LIGHT FINISHING CONVOLUTE WHEELS	NON-WOVEN / INTERLEAF FLAP WHEELS
NORTON							
SCALE REMOVAL	BEST CHOICE						
STOCK REMOVAL		BEST CHOICE	2ND CHOICE				
HEAVY DEBURRING		BEST CHOICE	2ND CHOICE				
DECORATIVE FINISHING				BEST CHOICE	2ND CHOICE		
BLENDING			BEST CHOICE	2ND CHOICE			
CLEANING				2ND CHOICE	BEST CHOICE		
LIGHT DEBURRING			2ND CHOICE			BEST CHOICE	
LIGHT FINISHING			2ND CHOICE			BEST CHOICE	
POLISHING						BEST CHOICE	2ND CHOICE
BUFFING							BEST CHOICE

SURFACE FINISH VARIABLES

Changes in any one of many factors can affect the surface finish on the workpiece. This chart shows the effect on surface finish by changes in single factors of product specifications. Arrows have been used to signify the trend direction. The arrow length does not signify that the effect of each factor is equal.

Variable Factor	Rough Finish High Rms Reading	Smooth Surface Lower Rms Reading
1. Wheel Speed	Slow ←	→ Fast
2. Feed Speed	Faster (Long Scratch) ←	→ Slower (Short Scratch)
3. Oscillation	No Oscillation ←	→ Oscillation
4. Lubricants	Dry ←	→ Straight Oil
	← Water	→ Soluble Oil
	← Compounds →	

NON-WOVEN MARKING SYSTEM

ABRASIVE	S/C					A/O
	SHARPER, FINER/BRIGHTER SCRATCH PATTERN					MORE DURABLE, LONGER LASTING, POLISHED FINISH
GRIT SIZE	XC (24-36)	C (50-80)	M (100-150)	F (180-220)	VF (240-360)	
	FASTER, AGGRESSIVE CUT, ROUGHER FINISH			REDUCED CUT RATE, FINER FINISH		
DENSITY	2					9
	SOFT, OPEN, CONFORMABLE, LESS BURNING/LOADING				HARDER, MORE DURABLE, FASTER CUTTING, BETTER FINISH	

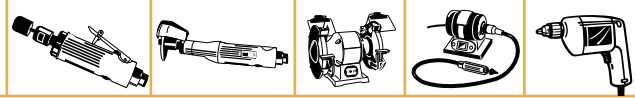

CROSS REFERENCE GUIDE

	STRIPPING	HEAVY/LIGHT DEBURRING	LIGHT DEBURRING/BLENDING/POLISHING				CLEANING/FINISHING		
NORTON	GOOD Rapid Strip	BEST Vortex Rapid Blend	GOOD NEX Rapid Blend	BEST Series 4000	BETTER Series 1000	BEST Light Finishing	BEST Metal Finishing	GOOD Clean & Finish	GOOD Non-Woven / Interleaf Flap Wheels
3M	Clean Strip	Cut & Polish Unitized	EXL Unitized	EX2 & EX3	EXL Deburring	Light Deburring	Metal Finishing	Multi Finishing	Finishing Flap Brush
Standard	Britestrip	800 & 900 Series	500 - 700 Series	GP Plus	Deburring Convolute	LDW	Metal Finishing	Multi Finishing	Buff & Blend Flap Brush



Rapid Strip Wheels

- Rapid Strip material provides a unique combination of aggressive performance, long life and improved finish. It is ideal for removing coatings on a variety of substrates, such as wood, metal and plastics.
- Incorporated with extruded nylon fibers, flexible resin technology and extra-coarse silicon carbide mineral that provide aggressive performance while outperforming traditional coated abrasives. They leave a thoroughly cleaned surface that ensures excellent adhesion for subsequent processes such as coating, painting and soldering.

AVAILABILITY

TIER: **GOOD**
TRADENAME: **RAPID STRIP WHEELS**

SIZE	MAX. RPM	STD. PKG.	PART NO.
Arbor Hole			
4 x 1/4	8,000	25	66261008008
4 x 1/2	8,000	25	66261007916
6 x 1/2	5,500	15	66261008051
8 x 1/2	3,000	24	08834191432
Mandrel-Mounted			
4 x 1/2 x 1/4 sk.	8,000	5	08834120974
4 x 1 x 1/4 sk.	8,000	5	08834120973

Rapid Blend Unified Wheels

- Designed for maintenance operations needing an efficient and cost-effective method of deburring, polishing, cleaning or finishing metals and composites. Easily preformed for use on a wide variety of shapes / contours. Hold shape well; less wheel dressing. Non-metallic so no contamination of workpiece. Uniform construction maintains part tolerance; prevents cutting or gouging.



NORTON VORTEX RAPID BLEND UNIFIED WHEELS

BETTER CHOICE FOR LIGHT WELD BEAD AND WELD SPLATTER REMOVAL, HEAVY DEBURRING AND FINISHING APPLICATIONS

FEATURES

- High-performance engineered grain and improved resin bond system
- Thick nylon web
- Controlled porosity

BENEFITS

- Aggressive, fast, stock removal, reduced cycle times, and increased part quality
- 2X longer life and faster finishing – with minimal shedding
- Cool cutting and improved cut rate

AVAILABILITY

TIER: **BETTER**
TRADENAME:

NORTON VORTEX RAPID BLEND UNIFIED WHEELS

SIZE (D x T x H)	ABRASIVE	GRIT SIZE	STD. PKG.	MAX. RPM	3 DENSITY PART NO.	MAX. RPM	5 DENSITY PART NO.	MAX. RPM	7 DENSITY PART NO.	MAX. RPM	9 DENSITY PART NO.
2 x 1/8 x 1/8	A/O	M	60			22,000	66254425657	20,000	66254410849		
2 x 1/8 x 1/4	A/O	M	60			22,000	66254406346	22,000	66261191446		
2 x 1/4 x 1/4	A/O	M	60	18,000	66254428456	22,000	66254433504	22,000	66261080270		
2 x 1 x 1/4	A/O	M	15					22,000	66261080269		
3 x 1/8 x 1/4	A/O	M	40			18,000	66261093448	18,000	66261191445		
3 x 1/8 x 3/8	A/O	M	40			18,000	66254433503	18,000	66254401131		
3 x 1/4 x 1/4	A/O	M	40	12,000	66254428454	18,000	66254414832	18,000	66261199696		
3 x 1/4 x 3/8	A/O	M	40	12,000	66254433505	12,000	66254433506	18,000	66261199697		
3 x 1/2 x 1/4	A/O	M	20			18,000	66254432925	18,000	66261080267	18,000	66254433507
3 x 1/2 x 3/8	A/O	M	20			18,000	66254433508	18,000	66261080266	18,000	66254420696

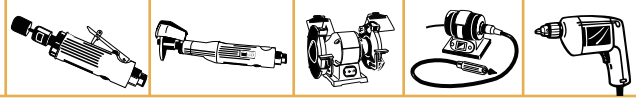

Rapid Blend Unified Wheels CONTINUED



NEX RAPID BLEND WHEELS

GOOD CHOICE FOR LIGHT DEBURRING AND BLENDING

FEATURES

- Uniform construction
- Smear-resistant formula

BENEFITS

- Extra long life
- Excellent, consistent, smear-free finishes

AVAILABILITY

TIER:

GOOD

TRADENAME:

NORTON NEX RAPID BLEND UNIFIED WHEELS

SIZE (D x T x H)	ABRASIVE	GRIT	MAX. RPM	STD. PKG.	2 DENSITY PART NO.	3 DENSITY PART NO.	4 DENSITY PART NO.	6 DENSITY PART NO.	7 DENSITY PART NO.	8 DENSITY PART NO.
1 x 1 x 3/16	A/O	C	30,000	50						66261014915
	A/O	M	18,000		66261014891					
	A/O	M	30,000					66261014908		66261014924
	A/O	F	30,000					66261014900		
	S/C	F	18,000		66261014883					
	S/C	F	30,000					66261014904		66261014923
2 x 1/8 x 1/4	A/O	M	22,000	60						66261014927
2 x 1/4 x 1/4	A/O	C	22,000	60						66261014916
	A/O	M	18,000		66261014892					
	A/O	M	22,000							66261014926
	A/O	F	22,000					66261014901		
	S/C	M	22,000							66261014964
	S/C	F	18,000		66261014884					
2 x 1/2 x 1/4	A/O	M	22,000	30						66261014925
3 x 1/8 x 1/4	A/O	M	18,000	40						66261014934
3 x 1/4 x 1/4	A/O	C	18,000	40						66261014919
	A/O	M	12,000		66261014894					
	A/O	M	18,000					66261014909		66261014930
	A/O	F	18,000				66261015565	66261014902		
	S/C	M	18,000							66261014937
	S/C	F	12,000		66261014886	66261016392				
3 x 1/4 x 3/8	A/O	C	18,000	40						66261014920
	A/O	M	12,000		66261014895					
	A/O	M	18,000					66261014910		66261014933
	A/O	F	12,000				66261014899			
	S/C	M	18,000							66261014965
	S/C	F	12,000		66261014887	66261016006				
S/C	F	18,000					66261014905			
3 x 1/2 x 1/4	A/O	C	18,000	20						66261014917
	A/O	M	12,000		66261014893					
	A/O	M	18,000					66261014928		
	S/C	F	12,000		66261014885					
3 x 1/2 x 3/8	A/O	C	18,000	20						66261014918
	A/O	M	18,000							66261014929
	S/C	XC	14,000						66261014914	
3 x 1 x 3/8	S/C	XC	14,000	10						
6 x 1/2 x 1	A/O	M	7,500	4						66261014931
6 x 1 x 1	A/O	M	5,000	2	66261014896					
	S/C	F	5,000		66261014888					

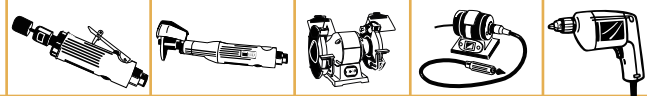

Rapid Blend Unified Wheels CONTINUED

AVAILABILITY

TIER: **GOOD**

TRADENAME:

**GENERAL DUTY
RAPID BLEND
UNIFIED WHEELS**

SIZE (D x T x H)	ABRASIVE	GRIT	DENSITY	MAX. RPM	STD. PKG.	PART NO.
1 x 1 x 3/16	A/O	C	8	15,000	50	66261000938
2 x 1/4 x 1/4	A/O	C	8	11,000	60	66261052275
2 x 1/2 x 1/4	A/O	F	4	11,000	40	66261058764
3 x 1/4 x 1/4	A/O	C	8	8,000	40	66261052276
	A/O	F	4	8,000		66261058816
	S/C	F	4	8,000		66261000745
3 x 1/2 x 1/4	A/O	F	4	8,000	20	66261054046
	S/C	F	4	8,000		66261054048
3 x 3/4 x 1/4	A/O	F	4	8,000	20	66261058769
	S/C	M	4	8,000		66261058773
	S/C	F	4	8,000		66261058771
6 x 1/2 x 1/2	S/C	M	4	4,800	8	66261058779
6 x 1 x 1/2	S/C	M	4	4,800	4	66261058792
	S/C	F	4	4,800		66261058790
6 x 1 x 1	S/C	F	4	4,800	4	66261058797

Mandrels for Unified Wheels

FITS WHEEL CENTER HOLE	FOR WHEEL WIDTH	FOR WHEEL DIAMETER	SHANK DIAMETER	OVERALL LENGTH	WASHER DIAMETER	3M EQUIVALENT	STD. PKG.	PART NO.
Mandrel Assemblies for Unified Wheels and Discs on Edge								
1/8" – 3/16"	Up to 1/2"	Up to 2"	1/8"	1-3/4"	7/16"	931	1	66261009849
3/16"	1/8" – 1/2"	1" – 2"	1/4"	2"	7/16"	994	1	66261009852
1/4" – 5/16"	Up to 1/2"	Up to 2"	1/4"	2"	5/8"	932	1	66261015146
1/4" – 5/16"	Up to 1"	Up to 2"	1/4"	2-1/2"	5/8"	932	1	66261059422
	Up to 1"	2" – 3"	1/4"	2-1/2"	1"	933	1	66261059421
3/8"	Up to 1/2"	2" – 4"	1/4"	2-1/2"	1"	990	1	66261009851
1/2"	Up to 1"	3" – 6"	1/4"	3-1/8"	1-5/8"	934	1	66261009850

SHANK LENGTH	SHANK DIAMETER	FOR CENTER HOLE	USE WITH UNIFIED WHEEL	3M EQUIVALENT	STD. PKG.	PART NO.
Threaded Mandrel for Unified Wheels						
1-3/4"	1/4"	3/16	1 x 1 x 3/16	948	5	66261047584



MANDREL ASSEMBLY 66261059421 FOR UNIFIED WHEELS



MANDREL ASSEMBLY 66261059422 FOR UNIFIED WHEELS



THREADED MANDREL 66261047584 FOR UNIFIED WHEELS



Convolute Wheels

- Formed by wrapping and bonding web material impregnated with abrasive grain and resin around a center core. Convolute wheels offer a wide range of uses from burr removal to cleaning rust and oxides.
- Burr and flashing removal
- Surface roughness reduction
- Blending weld areas on stainless steel
- Blending scratch patterns
- Weld polishing
- Removing rust and oxides
- Applying decorative finishes including antique patterns

FEATURED PRODUCTS

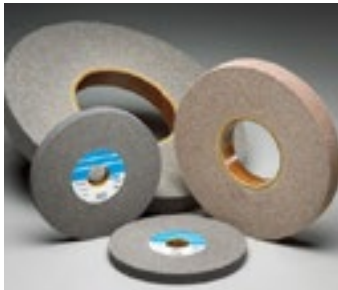

SERIES 4000 RAPID FINISH CONVOLUTE WHEELS
BEST CHOICE FOR HEAVY DEBURRING APPLICATIONS

FEATURES

- Advanced resin bond system
- High quality synthetic web

BENEFITS

- Free cutting
- Use both wet and dry
- Long life for heavy deburring, edge breaking and removing parting lines on exotic metals

AVAILABILITY

TIER: **BEST**

TRADENAME: **SERIES 4000 RAPID FINISH CONVOLUTE WHEELS**

SIZE (D x T x H)	ABRASIVE	GRIT	MAX. RPM	STD. PKG.	8 DENSITY PART NO.	9 DENSITY PART NO.
Series 4000 RapidFinish Convolute Wheels						
6 x 1/2 x 1	S/C	F	6,000	4		66261004021
6 x 1 x 1	A/O	M	6,000	3	66261004208	
	S/C	F			66261004142	66261004141
8 x 1 x 3	A/O	M	4,500	3	66261004165	
	S/C	F			66261004123	66261004135
12 x 1 x 5	S/C	F	3,000	2	66261004284	66261004148
12 x 2 x 5	S/C	F	3,000	1		66261004011

TECHtip

- Convolute wheels must always run in the direction indicated by the arrow printed on the side of each wheel.
- Light to medium pressure is recommended. Excessive pressure may result in part damage.
- Lubricants such as water-soluble oil and straight oil will decrease the heat and improve the surface finish and lustre.



It is the user's responsibility to refer to and comply with all safety regulations.



Convolute Wheels CONTINUED



SERIES 1000 RAPID FINISH CONVOLUTE WHEELS

BETTER CHOICE FOR GENERAL DEBURRING, BLENDING, AND FINAL FINISHING

FEATURES

- Smear and heat-resistant formula
- Dense web construction (9 density)
- More open web construction (7 density)
- Waterproof
- Non-metallic
- Optimum grain/resin formulation
- Conformable and flexible

BENEFITS

- Consistent, high quality results
- Starting point for deburring, blending, polishing and finishing applications
- Smear-proof and cool cutting on light deburring applications
- Use dry, wet or with oil
- No contamination of workpiece
- Durable, long life construction with versatile application range and improved cut rate and shed resistance
- Less operator fatigue

AVAILABILITY

TIER: **BETTER**
TRADENAME:

SERIES 1000 RAPID FINISH CONVOLUTE WHEELS

SIZE (D x T x H)	ABRASIVE	GRIT	MAX. RPM	STD. PKG.	7 DENSITY PART NO.	8 DENSITY PART NO.	9 DENSITY PART NO.
Series 1000 Long Life RapidFinish Convolute Wheels							
6 x 1/2 x 1	A/O	M	6,000	4	66261018857	66261018789	66261018650
	S/C	M					66261019540
	S/C	F					66261018629
6 x 1 x 1	A/O	M	6,000	3	69957397884	66261018636	66261019337
	S/C	M					66261018630
	S/C	F					66261018632
8 x 1 x 3	A/O	M	4,500	3	69957397885	66261018855	66261018633
	S/C	M					66261018997
	S/C	F					66261018641
12 x 1 x 5	A/O	M	3,000	2	69957397887	66261018786	66261018896
	S/C	M					66261018908
	S/C	F					66261018626



LIGHT FINISHING CONVOLUTE WHEELS

BEST CHOICE FOR LIGHT DEBURRING, POLISHING, AND FINE FINISHING APPLICATIONS

FEATURES

- Controlled cut rate
- Very conformable
- Superior form holding
- New resin bond system
- Advanced manufacturing process

BENEFITS

- Prevents "over benching"
- Deburs and polishes without altering geometry
- Operator friendly, reduces fatigue
- Consistent, reliable edge breaking and finishing with minimal wheel dressing and reshaping
- Less dust and shedding with more uniform wear
- Substantial extended wheel life in a soft, conformable wheel
- Improved web forming and grain distribution produce consistent finish on intricate polishing applications

AVAILABILITY

TIER: **BEST**
TRADENAME:

LIGHT FINISHING CONVOLUTE WHEELS

SIZE (D x T x H)	ABRASIVE	GRIT	MAX. RPM	STD. PKG.	6 DENSITY PART NO.	7 DENSITY PART NO.	8 DENSITY PART NO.
Light Finishing Convolute Wheels							
6 x 1/2 x 1	S/C	F	6,000	4	66261092322	66261092324	66254421572
6 x 1 x 1	S/C	F	6,000	3	66254403708	66254403709	66254421573
8 x 1/2 x 3	S/C	F	4,500	4	66254403707	66254409698	66254421575
8 x 1 x 3	S/C	F	4,500	3	66261095702	66254409924	66254421577
12 x 1 x 5	S/C	F	3,000	3		66261092480	66254421574*

* 2 PER STANDARD PACKAGE



Convolute Wheels CONTINUED



METAL FINISHING CONVOLUTE WHEELS

BEST CHOICE FOR DECORATIVE FINISHING, BLENDING, AND FINAL FINISHING.

FEATURES

- Premium, medium grit aluminum oxide grain
- Dense, very durable web
- Strongest resin binders
- Uniform grain dispersion and coating
- Available in 5 and 6 densities

BENEFITS

- Generates uniform distinct satin and antique finishes
- Can be used for blending applications
- Resilient, long life construction
- Clean and condition without gouging or changing dimensions of workpiece
- Ideal for blending and matching #3 and 4 mil. finishes, and surface prep for buffing, polishing and applying decorative finishes

AVAILABILITY

TIER: **BEST**

TRADENAME: **METAL FINISHING CONVOLUTE WHEELS**

SIZE (D x T x H)	ABRASIVE	GRIT	DENSITY	MAX. RPM	STD. PKG.	PART NO.
Metal Finishing Convolute Wheels						
6 x 1 x 1	A/O	M	5	6,000	3	66261007936
		M	6			66261010148
6 x 2 x 1	A/O	M	5	6,000	2	66261007957
		M	6			66261009635
8 x 1 x 3	A/O	M	5	4,500	3	66261007831
8 x 2 x 3	A/O	M	5	4,500	2	66261007904
		M	6			66261012971
12 x 1 x 5	A/O	M	5	3,000	2	66261007434
		M	6			66261009481
12 x 2 x 5	A/O	M	5	3,000	1	66261007212
14 x 2 x 8	A/O	M	5	2,550	1	66261007817
		M	6			66261012041



CLEAN & FINISH CONVOLUTE WHEELS

BEST CHOICE FOR FINE FINISH WITH LIGHT PRESSURE

FEATURES

- Silicon carbide grain
- Open mesh construction

BENEFITS

- Good for blending, rust removal, applying decorative, contrast finishes and low- to moderate-speed applications
- Not used for deburring
- Used with light to moderate pressure, low speed

AVAILABILITY

TIER: **BEST**

TRADENAME: **CLEAN & FINISH CONVOLUTE WHEELS**

SIZE (D x T x H)	ABRASIVE	GRIT	DENSITY	MAX. RPM	STD. PKG.	PART NO.
Clean & Finish Convolute Wheels						
4 x 1 x 1	S/C	M	4	4,000	10	66261058502
		F	4			66261058501
6 x 1 x 1	S/C	M	4	3,000	4	66261058507
		F	4			66261058506
6 x 2 x 1	S/C	M	4	3,000	2	66261058510
		F	4			66261058509
6 x 3 x 1	S/C	M	4	3,000	1	66261058512
6 x 4 x 1	S/C	M	4	3,000	1	66261058514
8 x 1 x 3	S/C	M	4	2,500	3	66261058518
8 x 2 x 3	S/C	M	4	2,500	2	66261058521
8 x 3 x 3	S/C	M	4	2,500	1	66261058524
8 x 4 x 3	S/C	M	4	2,500	1	66261058526



Aluminum Reducing Bushings for Flap and Convolute Wheels



- Durable, aluminum one-piece-design flanges with integrated “contact washer”
- Snug fit; extended usable life
- Available in stock and non-stock sizes: 3" up to 10" in many combinations of ID hole reduction

WHEEL CENTER HOLE	BUSHING REDUCES HOLE SIZE TO	FOR WHEEL DIAMETER	STD. PKG.	PART NO.
Aluminum Reducing Bushing for Flap and Convolute Wheels				
1	3/8	4 - 6	1 Pair	66261080522
	1/2			66261080523
	5/8			66261080524
	3/4			66261080525
	7/8			66261080526
2	1/2	6	1 Pair	66261080527
	5/8			66261080528
	1			66261080529
	1-1/4			66261080530
3	1	8	1 Pair	66261080531
	1-1/4			66261080532
	1-1/2			66261080383
	1-3/4			66261080384
	2			66261080514
5	1	10 and 12	1 Pair	66261080533
	1-1/4			66261080534
	3			66261080535
8	1-1/4	14	1 Pair	66261080536
	3			66261080512
10	1-1/4	16	1 Pair	66261080520



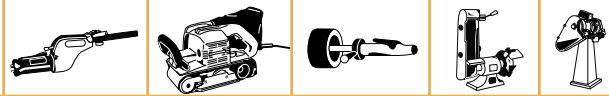

CATEGORY DEFINITION

Norton non-woven belts are a combination of strong synthetic mesh and quality abrasive, bonded together by a smear-resistant adhesive. The open construction of non-woven material enables aggressive cutting action and improved surface finish while maintaining its non-loading feature.

APPLICATIONS: Removing surface defects, light edge burrs, parting lines, flashing, rust, oxides, corrosion, paints, and scale; blending mill marks, tool marks, uneven edges, and applying decorative finishes.

ABRASIVE GRAIN: Aluminum Oxide

GRIT RANGE: Extra Coarse (Black), Coarse (Brown), Medium (Maroon), Fine (Green), Very Fine (Blue)

FEATURED PRODUCTS



NEW

NORTON VORTEX RAPID PREP NON-WOVEN BELTS

BETTER CHOICE FOR FINISHING AND BLENDING APPLICATIONS

FEATURES

- Proprietary Vortex aluminum oxide abrasive grain and new coating method

BENEFITS

- Most consistent cutting and finishing of surface conditioning products on the market
- Combine the cutting speed with the finish of fine grits
- Reduce process times by 50+% by eliminating 2 to 5 grit sequences to 1 step in your technical blending operations
- More resistant to edge wear; up 4X life vs. competitive products
- Friable grain structure keeps Ra specs throughout disc life and reduces scrap and rework



NEW

NORTON RAPID PREP

GOOD CHOICE FOR FINISHING AND BLENDING APPLICATIONS

FEATURES

- New resin system, aerospace-tailored
- Proprietary new coating method
- Extended form holding
- Improved hook and loop backing

BENEFITS

- Smear-free, even on high nickel content alloys
- Will not load on aluminum and soft metals, as competitive products may
- Thick layer of grain throughout the product extends life; grain does not sit on top of fibers as other competitive products may
- Lowest total cost of consumable tooling per workpiece
- Will not fly off rotary sanders
- Discs sit flatter on back-up pads, resulting in a more consistent finish on DA applications

APPLICATION/GRIT RECOMMENDATION GUIDE

	EXTRA COARSE	COARSE	MEDIUM	FINE	VERY FINE
	BETTER CHOICE - NORTON VORTEX RAPID PREP				
	GOOD CHOICE - NORTON RAPID PREP				
Scale Removal	X				
Stock Removal		X			
Heavy Deburring		X			
Light Deburring			X		
Light Finishing			X		
Blending				X	
Finishing					X

NON-WOVEN BELTS

MACHINES USED

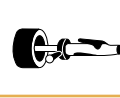

Norton Vortex Rapid Prep

WIDTH	LENGTH	EXTRA COARSE	COARSE	MEDIUM	FINE	VERY FINE
1/4"	18"	66623335142	66623335025	66623335084	66623333637	66623333680
1/4"	24"	66623335143	66623335026	66623335087	66623333638	66623333681
1/2"	12"	66623312664	66623312665	66623335089	66623335073	66623335125
1/2"	18"	66623312677	66623312678	66623314290	66623333639	66623335126
1/2"	24"	66623312668	66623312670	66623335091	66623335075	66623335127
3/4"	18"	66623312672	66623312675	66623335093	66623335077	66623335128
3/4"	20-1/2"	66623333705	66623335027	66623335094	66623333640	66623333682
3/4"	80"	66623333706	66623335028	66623333672	66623333641	66623333683
1"	18"	66623333707	66623335028	66623335095	66623333642	66623333684
1"	21"	66623333708	66623333623	66623333673	66623333643	66623333685
1"	30"	66623333709	66623335029	66623335096	66623333644	66623335129
1"	42"	66623333710	66623335030	66623335097	66623333645	66623333686
1"	60"	66623333711	66623333624	66623333674	66623333646	66623335130
1"	64"	66623333712	66623333625	66623335098	66623333647	66623335131
1"	72"	66623333713	66623335033	66623335099	66623335079	66623335132
1"	132"	66623335145	66623335032	66623335100	66623335080	66623333687
1-1/2"	60"	66623335146	66623333626	66623335101	66623333648	66623335133
2"	18-15/16"	66623313274	66623335031	66623333675	66623333649	66623333688
2"	34"	66623333714	66623335034	66623335102	66623333650	66623333689
2"	48"	66623333715	66623335035	66623335103	66623333651	66623333690
2"	60"	66623335147	66623333627	66623335104	66623333652	66623333691
2"	72"	66623333716	66623335036	66623335105	66623333653	66623335134
2"	132"	66623335148	66623335037	66623335106	66623335083	66623333692
2-1/2"	60"	66623333717	66623335038	66623335108	66623333654	66623333693
2-3/4"	15-1/2"	66623333718	66623333628	66623333676	66623333655	66623333694
3"	10-11/16"	66623333719	66623335039	66623335110	66623333656	66623333695
3"	18"	66623335149	66623335040	66623335112	66623333657	66623335135
3"	21"	66623333720	66623333629	66623335113	66623333658	66623333696
3"	24"	66623335150	66623333630	66623335114	66623333659	66623335136
3"	72"	66623333721	66623333631	66623335115	66623333660	66623335137
3"	80"	66623333722	66623333632	66623335116	66623333661	66623333697
3"	90"	66623333723	66623333633	66623333677	66623333662	66623333698
3"	118"	66623333724	66623333634	66623333678	66623333663	66623335138
3"	132"	66623335151	66623335041	66623335117	66623333664	66623333699
3-1/2"	15-1/2"	66623333725	66623335042	66623335118	66623333665	66623335139
4"	24"	66623333726	66623335043	66623335119	66623333666	66623333700
4"	36"	66623333727	66623333635	66623335120	66623333667	66623333701
4"	132"	66623333729	66623335044	66623335121	66623333668	66623333703
4"	168"	66623333730	66623335045	66623335122	66623333669	66623333704
6"	48"	66623333731	66623335046	66623335123	66623333671	66623335140

Norton Rapid Prep

WIDTH	LENGTH	EXTRA COARSE	COARSE	MEDIUM	FINE	VERY FINE
1/4"	18"	66623305511	66261011420	66261012524	66623333424	66623333511
1/4"	24"	66261097566	69957392606	66261097565	66623333425	66623333512
1/2"	12"	66623333550	66261003177	66261006465	66623318175	66254499884
1/2"	18"	66261017507	66261055309	66261055310	66623333426	66261055311
1/2"	24"	66261017288	66261055312	66261008972	66254490859	66261019876
3/4"	18"	66261016493	66261002111	66261015808	66254490858	66261003622
3/4"	20-1/2"	66623333551	66261083899	66261003260	66623333427	66623333515
3/4"	80"	66623333554	66623333411	66254441289	66623333428	66623333516
1"	18"	66623333555	66261007023	66261017898	66623333429	66623333518
1"	21"	66623333556	66623333412	66623336005	66623333430	66623333519
1"	30"	66623333558	66261019801	66623336006	66623333431	66261001972
1"	42"	66623333560	66261008317	66623336007	66623333432	66623333521
1"	60"	66623333562	66623333413	66623335006	66623333433	66261055412
1"	64"	66623333564	66623333414	66623301513	66623333434	66261055413
1"	72"	66623333566	66261194240	66261006378	66254493830	66261005583
1"	132"	66625442093	66623314981	66261011414	66254436886	66623333525
1-1/2"	60"	66254425298	66623333415	66261007644	66623333435	66623303624
2"	18-15/16"	66261018226	66261018224	66623333507	66623333436	66623333528
2"	34"	66623333572	66261063309	66623312203	66623333437	66623333529
2"	48"	66623333573	66261006504	66623306648	66623333438	66623333531
2"	60"	66261055561	66623333416	66261189669	66623333439	66623333532
2"	72"	66623333574	66261002571	66261007757	66623333440	66261002307
2"	132"	66261017511	66261008491	66261008492	66261069525	66623333533
2-1/2"	60"	66623333576	66254429365	66254441491	66623333441	66623333534
2-3/4"	15-1/2"	66623333578	66623333417	66623335008	66623333442	66623333535
3"	10-11/16"	66623333580	66261018076	66261067469	66623333443	66623333536
3"	18"	66254428772	66254496043	66254428776	66623333444	66261019836
3"	21"	66623333584	66623333418	66261010870	66623333445	66623333537
3"	24"	66254433359	66254433358	66254428773	66623333446	66261055593
3"	72"	66623333586	66623333419	69957396833	66623333447	66261003176
3"	80"	66623333588	66623333420	66261007149	66623333448	66623333542
3"	90"	66623333590	66623333421	66623333509	66623333449	66623333541
3"	118"	66623333592	66623333422	66623333510	66623333450	66261047121
3"	132"	66261016514	66254490470	66261055322	66623333451	66623333543
3-1/2"	15-1/2"	66623333595	66261055324	66254444576	66623333452	66261055326
4"	24"	66623333596	66254495931	66261031667	66623333453	66623333545
4"	36"	66623333597	66623333423	66261002321	66623333454	66623333546
4"	132"	66623333599	66261009056	66261006898	66623333455	66623333547
4"	168"	66623333600	63642576650	66261009174	66623333456	66623333548
6"	48"	66623333602	66261055330	66261055331	66623333457	66261055332

Merit Surface Prep

WIDTH	LENGTH	EXTRA COARSE	COARSE	MEDIUM	FINE	VERY FINE
1/4"	18"	08834190391	08834190961	77696064544	66623333469	08834190960
1/4"	24"	66623311055	08834190963	08834194060	66623333470	08834190962
1/2"	12"	63642582266	66254441799	66261019760	66623333471	66261096581
1/2"	18"	08834199002	66623333393	66261071010	66623333472	08834194002
1/2"	24"	66261041203	05539570453	66623333498	66623301573	66623333513
3/4"	18"	08834199776	66623333394	66261192907	66623333473	66623333514
3/4"	20-1/2"	66623333552	66254499800	08834194010	66623333474	08834194011
3/4"	80"	66623333553	66623333395	66623333499	66623333475	66623333517
1"	18"	08834199003	08834190970	08834198035	66623333476	08834190968
1"	21"	66623333557	66623333396	66254482190	66623333477	66623333520
1"	30"	66623333559	08834199508	08834194072	66623333478	08834199509
1"	42"	66623333561	08834194012	08834194013	66623333479	08834194014
1"	60"	66623333563	66623333397	66623333500	66623333480	66623333522
1"	64"	66623333565	66623333398	66623333501	66623333481	66623333523
1"	72"	66623333567	66623333399	66623328846	66623333482	66261030821
1"	132"	66623333568	66261046477	66254491234	66623333483	66623333524
1-1/2"	60"	66623333569	66623333400	69957396806	66623333484	66623333526
2"	18-15/16"	66623333570	66623333401	08834190146	66623333485	66623333527
2"	34"	66623333571	66623333402	66623312395	66623333486	66623333530
2"	48"	66623329040	08834194015	05539568393	66623333487	08834194017
2"	60"	08834199006	08834194018	08834194019	66623333488	08834194020
2"	72"	08834199007	08834194021	08834194022	66623333489	08834194023
2"	132"	66623333575	08834194024	08834194025	66623333490	08834194026

CONTINUED

WIDTH	LENGTH	EXTRA COARSE	COARSE	MEDIUM	FINE	VERY FINE
2-1/2"	60"	66623333577	08834194030	08834194031	66623333491	08834194032
2-3/4"	15-1/2"	66623333579	66623333403	08834194034	66623333493	08834194035
3"	10-11/16"	66623333581	05539568397	08834190976	66623333494	08834190975
3"	18"	66623333582	08834190979	66623333502	66623333495	08834190977
3"	21"	66623333583	08834190959	08834194103	66623333496	08834194129
3"	24"	66623333585	66254402501	08834194037	66623333497	08834194038
3"	72"	66623333587	66623333404	66623327858	66623333468	66623333538
3"	80"	66623333589	66623333405	66254469978	66623333467	66623333539
3"	90"	66623333591	66623333406	05539527159	66623333466	66623333540
3"	118"	66623333593	66623333407	66623333503	66623333465	66623333544
3"	132"	66623333594	08834194039	63642596252	66623333464	08834194041
3-1/2"	15-1/2"	08834199009	66623333408	08834198042	66623333463	08834194044
4"	24"	08834199010	08834194045	088		



CATEGORY DEFINITION

Non-woven surface finishing flap wheels are an ideal choice for a wide variety of blending and finishing applications common in the metal fabrication, welding and polishing industries. Flap wheels are conformable to intricate shapes and contours. Designed to deliver a consistent finish with a uniform rate of cut, flap wheels wear away continually exposing fresh abrasives.

There are two types of non woven flap wheels: non-woven only abrasive flaps where finishing is the primary application, and interleaf with alternating cloth and non-woven abrasive flaps (less conformable, more aggressive) for stock removal and finishing. Interleaf flap wheels must always be run in the direction indicated by the arrow.

- APPLICATIONS:** Used for a wide range of metal fabrication and welding applications including blending, deburring, cleaning, finishing, and polishing
- SIZE RANGE:** Flap wheels with mounted steel shanks: 2" – 3" diameter
Flap wheels with arbor holes: 3" – 12" diameter
- GRIT RANGE:** 50 – 320
- ABRASIVE GRAIN:** Aluminum Oxide, Silicon Carbide

APPLICATION/GRIT RECOMMENDATION GUIDE

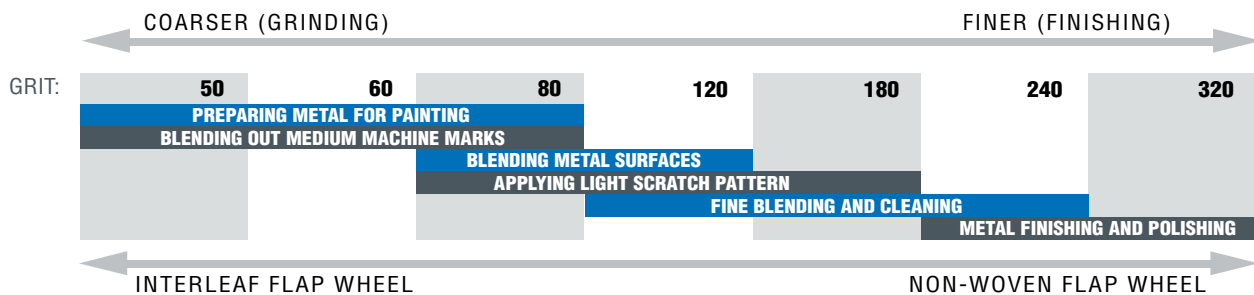

1/4" Mounted Steel Shanks

AVAILABILITY

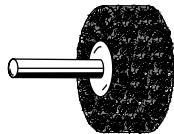

TIER:
BRAND:
TRADENAME:

SIZE (D x W x SK.)	MAX. RPM	ABRASIVE	CA GRIT	NON-WOVEN GRIT	STD. PKG.	PART NO.	PART NO.	PART NO.	PART NO.
2 x 1 x 1/4	12,000	A/O	60	Coarse	10	66261051720*	08834138122		
		A/O	80	Medium		66261051721*	08834138123		
		A/O	120	Medium		66261051722*	08834144457	66261051716*	66261189992*
		A/O	180	Fine		08834144458	08834144458	66261051717*	69957399202*
		A/O	320	Very Fine		08834144459	08834144459		
2 x 1-1/2 x 1/4	12,000	A/O	60	Coarse	10		08834138124		
		A/O	80	Medium		08834138125			
		A/O	120	Medium		08834138126			
		A/O	180	Fine		08834138127			
		A/O	320	Very Fine		08834138128			
3 x 1 x 1/4	12,000	A/O	60	Coarse	10		08834138129		
		A/O	80	Medium		08834138130			
		A/O	120	Medium		66261051725*	08834138118	66261051718*	08834131921
		A/O	180	Fine		08834138120			
		A/O	320	Very Fine		08834138119		66261051719*	66261189993
3 x 1-3/4 x 1/4	12,000	A/O	–	Medium	10				66261026075
		A/O	–	Very Fine					66261189994
3 x 2 x 1/4	8,000	A/O	60	Grit	10		08834131338		
		A/O	80	Coarse		08834138116			
		A/O	120	Medium		08834144460	66261058474		
		A/O	180	Medium		08834144461			
4 x 2 x 1/4	12,000	A/O	80	Coarse	10		08834121115		
		A/O	120	Medium		08834120458			

*STANDARD PACKAGE QUANTITY = 20



Arbor Hole Mounts

AVAILABILITY



TIER:
BRAND:
TRADENAME:

SIZE (D x W x SK.)	MAX. RPM	ABRASIVE	CA GRIT	NON-WOVEN GRIT	STD. PKG.	INTERLEAF PART NO.	INTERLEAF PART NO.	NON-WOVEN PART NO.	NON-WOVEN PART NO.
3 x 2 x 3/8	12,000	A/O	50	Coarse	10		08834139022		
		A/O	60	Coarse			08834139000		
		A/O	80	Medium			08834139002		
		A/O	120	Medium			08834139001		
		A/O	180	Fine			08834139023		
		A/O	240	Very Fine			08834139028		
4 x 2 x 5/8	12,000	A/O	50	Coarse	10		08834126024		
		A/O	60	Coarse			08834126025		
		A/O	80	Medium			08834126026		
		A/O	120	Medium			08834126016		
		A/O	180	Fine			08834126015		
		A/O	240	Very Fine			08834126014		
6 x 1 x 1	6,000	A/O	50	Coarse	10		08834126027		
		A/O	60	Coarse			08834126028		
		A/O	80	Medium			08834126029		
		A/O	120	Medium			08834126000		
		A/O	150	Medium			08834126006		
		A/O	180	Fine			08834126046		
6 x 1 x 2	3,000	A/O	80	Medium	4	66261004418 66261007678 66261005387		66261058456	05539512667
		A/O	120	Medium				66261058487	05539562635
		A/O	180	Fine				66261058451	05539512660
		S/C	-	Fine				66261058450	05539512658
		S/C	-	Very Fine					
6 x 2 x 1	6,000	A/O	50	Coarse	10		08834126032		
		A/O	60	Coarse			08834126008		
		A/O	80	Medium			08834126009		
		A/O	120	Medium			08834126010		
		A/O	150	Medium			08834126069		
		A/O	180	Fine			08834126018		
		A/O	240	Very Fine			08834126017		
		A/O	320	Very Fine			08834126033		
6 x 3 x 1	6,000	A/O	50	Coarse	6		08834126053		
		A/O	60	Coarse			08834126054		
		A/O	80	Medium			08834126055		
		A/O	120	Medium			08834126056		
		A/O	180	Fine			08834126048		
		A/O	240	Very Fine			08834126047		
8 x 1 x 3	2,500	A/O	120	Medium	3	66261010711		66261058491	05539527460
		-	-	Fine					
8 x 2 x 1	4,500	A/O	60	Coarse	6		08834126041		
		A/O	80	Medium			08834126042		
		A/O	120	Medium			08834126043		
		A/O	180	Fine			08834126044		
8 x 2 x 3	2,500	A/O	-	Medium	2			66261000889	05539512677 05539526627
		A/O	-	Medium				66261058493	
		A/O	-	Fine					
8 x 3 x 1	4,500	A/O	50	Coarse	3		08834126060		
		A/O	60	Coarse			08834126066		
		A/O	80	Medium			08834126061		
		A/O	120	Medium			08834122398		
		A/O	180	Fine			08834126062		
		A/O	320	Very Fine			08834126064		
12 x 1 x 5	1,900	A/O	80	Medium	2	66261010712			
		A/O	120	Medium		66261004667			
12 x 2 x 5	1,900	A/O	-	Medium	1			66261005070	05539528945
		A/O	-	High Strength					05539562637

Refer to Non-Woven Convolute Wheel section for Flap Wheel Reducing Bushings.





NORTON

SAINT-GOBAIN

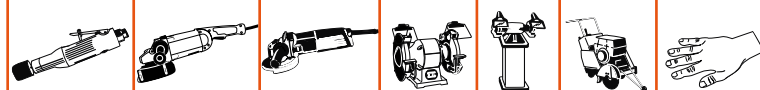

CATEGORY DEFINITION

Our broad Norton wire brush offering includes all the basic shapes and configurations: cups, saucer cups, wheel end brushes and hand brushes. Attractive packaging clearly explains dimensions, structure, safety and machine usage. All brushes are individually clamshell packaged unless otherwise noted. When using wire brushes, be sure to comply with ANSI B165 "Power-Driven Brushing Tools: Safety Requirement for the Design, Care and Use." and safety documents on www.nortonabrasives.com website.

APPLICATIONS: Cleaning rust, scale and dirt; light deburring; edge blending; roughening for adhesion; finishing for appearance; finish preparation prior to plating or painting

SHAPES: Cup, saucer cup, wheel, end brush, hand brush

WIRE DESIGN: Standard and full cable twist knot, crimped, stringer bead

OTHER: Color-coded for easy identification;

STAINLESS

STEEL/METAL

FEATURED PRODUCTS AND AVAILABILITY

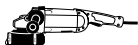

BETTER WIRE SAUCER CUP BRUSHES

IDEAL FOR CLEANING CORNERS, RECESSES, AND OTHER HARD-TO-REACH AREAS – FOR STEEL/STAINLESS

FEATURES

- Twist knot style
- Crimped style

BENEFITS

- For heavy-duty cleaning
- For light- to medium-duty cleaning

DIAMETER X WIRE THICKNESS X MOUNT	MAX. RPM	STD. PKG.	APPLICATION	PART NO.
Twist Knot Saucer Cup				
4 x .020 x 5/8-11	15,000	5	Carbon	66252833483
5 x .020 x 5/8-11	12,500	10	Carbon	66252835585
5 x .020 x 5/8-11	12,500	10	Stainless	66252835586

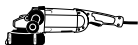

BETTER HIGH PERFORMANCE (HP) CABLE CRIMPED CUP BRUSHES

FOR LIGHT- TO MEDIUM-DUTY BRUSHING APPLICATIONS ON FLAT OR IRREGULAR SURFACES, AND BEVEL BUFFING – FOR STEEL

FEATURES

- 12 wires of .009" brass-coated steel are bundled together into a group, then crimped
- Cable crimped wire breaks down in smaller pieces than standard crimped brushes

BENEFITS

- Creates a 50% longer lasting brush compared to standard crimped brushes; better flexibility on irregular surfaces
- Safer wire to use
- Protective guard

DIAMETER X WIRE THICKNESS X MOUNT	MAX. RPM	STD. PKG.	APPLICATION	PART NO.
Crimped Cup with Protective Guard – Single Row				
3 x (12 x .009) x 5/8-11	15,000	5	Carbon	66252833493
4 x (12 x .009) x 5/8-11	9,000	5	Carbon	66252833494

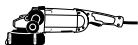

BETTER CRIMPED WIRE CUP BRUSHES

FOR LIGHT- TO MEDIUM-DUTY BRUSHING APPLICATIONS ON FLAT OR IRREGULAR SURFACES, AND BEVEL BUFFING – FOR STEEL

FEATURES

- Highly flexible heavy wire fill

BENEFITS

- Fast cutting

DIAMETER X WIRE THICKNESS X MOUNT	MAX. RPM	STD. PKG.	APPLICATION	PART NO.
3 x .014 x 5/8-11	15,000	5	Carbon	69936653341
4 x .014 x 5/8-11	9,000	5	Carbon	69936653347
6 x .014 x 5/8-11	6,000	5	Carbon	69936653348
6 x .020 x 5/8-11	6,000	5	Carbon	69936653349

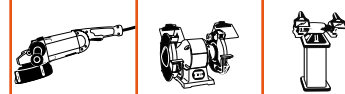

FEATURED PRODUCTS AND AVAILABILITY



BETTER TWIST KNOT WIRE CUP BRUSHES

HIGH IMPACT CUTTING AND CLEANING ON MORE DEMANDING APPLICATIONS – FOR STEEL/STAINLESS

FEATURES

- Rigid structure
- Available with or without plastic guard
- Protective guard opens up into a shield
- Single row, twist knot construction
- Double row, twist knot construction

BENEFITS

- High impact cutting and cleaning on more demanding applications
- Application-specific
- Prevents wire, dust and/or projection from reaching the end-user
- Provides for a friendly handling of the brush, preventing potential pricking caused by the wire ends
- Limits flaring of the brush on corners and angles
- More aggressive; provides twice the cutting points of a single row cup brush for heavy-duty action in very severe applications

DIAMETER X WIRE THICKNESS X MOUNT	MAX. RPM	STD. PKG.	APPLICATION	PART NO.
Knotted Cup With Protective Guard – Single Row				
2-3/4 x .020 x 5/8-11	15,000	5	Carbon	66252833492
4 x .020 x 5/8-11	9,000	5	Carbon	66252833496
5 x .020 x 5/8-11	6,500	5	Carbon	66252833497
Knotted Cup – Single Row				
2-3/4 x .020 x 5/8-11	15,000	5	Carbon	69936653336
2-3/4 x .020 x 5/8-11	15,000	5	Stainless	69936653340
4 x .020 x 5/8-11	9,000	5	Carbon	69936653345
4 x .020 x 5/8-11 with bridle	9,000	5	Stainless	66252833947
6 x .020 x 5/8-11	6,000	5	Carbon	69936605965
6 x .035 x 5/8-11	6,000	5	Carbon	69936602003
Knotted Cup – Double Row				
6 x .020 x 5/8-11	6,000	5	Carbon	69936653346

BETTER CRIMPED WIRE WHEEL BRUSHES

EXCELLENT PERFORMANCE FOR DEBURRING, REMOVING RUST, CORROSION AND DIRT – FOR STEEL

FEATURES

- Brushes may be used individually or stacked on a shaft

BENEFITS

- Single-section, narrow-faced brushes are ideal for general-purpose brushing of uneven or difficult-to-reach surfaces
- Single section, medium-faced brushes clean larger surface areas and have longer life

DIAMETER X WIRE THICKNESS X HOLE SIZE	MAX. RPM	STD. PKG.	APPLICATION	PART NO.
Crimped Narrow 3/4" Face				
6 x .014 x 1/2-2**	6,500	5	Carbon	69936653306
Crimped Medium 1" Face				
6 x .014 x 1/2-2**	6,500	5	Carbon	69936653324
8 x .014 x 1/2-2**	4,500	5	Carbon	69936653326

** 7 BUSHING SIZES INCLUDED WITH EACH BRUSH (FIT 1/2" - 2")

STAINLESS

STEEL/METAL

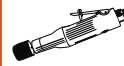

FEATURED PRODUCTS AND AVAILABILITY

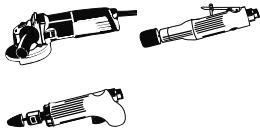
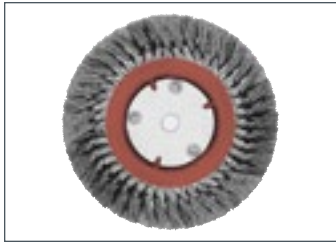

BETTER STANDARD TWIST KNOT WIRE WHEEL BRUSHES

IDEAL FOR WELDING AND METAL FABRICATION APPLICATIONS (REMOVING WELD SCALE SPATTER, EXTRA-HEAVY RUST AND CORROSION, OR SURFACE ROUGHENING) – FOR STEEL

FEATURES

- Twist knot wire design

BENEFITS

- Provides added rigidity for extra cutting power
- Small diameter wheels are used for small- to medium-duty jobs requiring flexibility and lighter brushing action

DIAMETER X WIRE THICKNESS X MOUNT/HOLE	MAX. RPM	STD. PKG.	APPLICATION	PART NO.
3 x .014 x 5/8-11	20,000	5	Stainless	66252836362
4-1/2 x .020 x 5/8-11	20,000	5	Carbon	69936606275

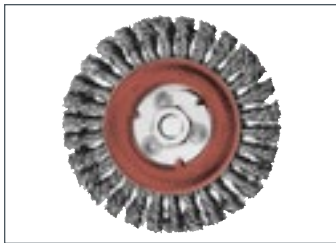

BETTER FULL CABLE TWIST KNOT WIRE WHEEL BRUSHES

FOR THE TOUGHER APPLICATIONS, ESPECIALLY FOR WELD PASSES – FOR STEEL/STAINLESS

FEATURES

- Full cable twist brushes
- Pipeline: heavy-duty knot construction

BENEFITS

- Provide very low flex and high impact cutting and cleaning
- Stiffer, longer-lasting knots for tougher applications / heavy build-up
- Longest life for brushing/cleaning joints and preparing expansion joints for filling and scaling

DIAMETER X WIRE THICKNESS X MOUNT	MAX. RPM	STD. PKG.	APPLICATION	PART NO.
4 x .020 x 5/8-11	20,000	5	Carbon	66252838300
4-1/2 x .020 x 5/8-11	20,000	6*	Carbon Pipeline	66252840466
4-1/2 x .020 x 5/8-11	20,000	6*	Carbon	69936653331
4-1/2 x .020 x 5/8-11	20,000	5	Stainless	69936653333
5 x .020 x 5/8-11	12,500	5	Carbon	66252833487
5 x .020 x 5/8-11	12,500	5	Stainless	66252833488
6 x .020 x 5/8-11	12,500	5	Carbon	69936653352
6 x .020 x 5/8-1/2	12,500	5	Carbon	69936653327

*BULK PACKED ITEMS



BETTER STRINGER BEAD KNOT WIRE WHEEL BRUSHES

DELIVER HIGH-IMPACT CUTTING AND CLEANING FOR TOUGHEST APPLICATIONS – FOR STEEL/STAINLESS

FEATURES

- Stringer bead wire for hard-to-reach areas
- Joint/Crack cleaning wire wheel brushes

BENEFITS

- Specially suited for groove and weld bead, corners, and t-connections
- Used for brushing joints, cleaning cracks in concrete and asphalt, and preparing expansion joints for filling and scaling
- Pipeline: longest life for brushing/cleaning joints and preparing expansion joints for filling and scaling

DIAMETER X WIRE THICKNESS X MOUNT	MAX. RPM	STD. PKG.	APPLICATION	PART NO.
For Right Angle Grinders				
4 x .020 x 5/8-11	20,000	5	Carbon	69936606277
4 x .020 x 5/8-11	20,000	6*	Carbon	66252833489
4 x .020 x 5/8-11	20,000	6*	Carbon Pipeline	66252840467
4 x .020 x 5/8-11	20,000	5	Stainless	69936606278
4 x .020 x 5/8-11	20,000	10*	Stainless Pipeline	66252842233
4 x .020 x 5/8-11 & 3/8-24	20,000	5	Carbon	66252840889
4-1/2 x .020 x 5/8-11	20,000	10*	Carbon Pipeline	66252842299
5 x .020 x 5/8-11	12,500	6*	Carbon	66252833490
5 x .020 x 5/8-11	12,500	6*	Stainless	66252833491
6 x .020 x 5/8-11	12,500	10*	Carbon	69936653350
6 x .020 x 5/8-11	12,500	10*	Carbon Pipeline	66252840469
6 x .020 x 5/8-11	12,500	5	Stainless	69936653351
6-7/8 x .020 x 5/8-11	9,000	10*	Carbon	69936653329
6-7/8 x .020 x 5/8-11	9,000	10*	Carbon Pipeline	66252840468
9 x .020 x 5/8-11	6,000	2	Carbon	66252837993

For Walk-Behind Machines – Joint/Crack Cleaning Brushes

12 x .035 x 1 - DP	4,500	2*	Carbon	69936606280
--------------------	-------	----	--------	-------------

*BULK PACKED ITEMS



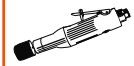

FEATURED PRODUCTS AND AVAILABILITY



BETTER END BRUSHES

CLEAN AND DEBURR A RECESSED AREA OR THE INSIDE DIAMETER OF A TUBE OR PIPE – FOR STEEL/STAINLESS

FEATURES

- Twist knot wire end brushes
- Crimped wire end brushes

BENEFITS

- For more aggressive cutting
- For lighter brushing action and contoured surfaces



DIAMETER X WIRE THICKNESS X MOUNT	MAX. RPM	STD. PKG.	APPLICATION	PART NO.
Stem Mounted Knotted				
3/4 x .020 x 1/4 Shank	20,000	10*	Carbon	69936653316
1 x .014 x 1/4 Shank	20,000	10*	Carbon	69936606279
1 x .020 x 1/4 Shank	20,000	10*	Carbon	69936653310
Stem Mounted Crimped				
3/4 x .006 x 1/4 Shank	20,000	10*	Stainless	69936606145
3/4 x .014 x 1/4 Shank	20,000	10*	Carbon	69936653317
1 x .020 x 1/4 Shank	20,000	10*	Carbon	69936653309
Copper Center				
2-1/2 x .014 x 1/2-3/8	20,000	12*	Carbon	69936653320

*BULK PACKED ITEMS



BETTER HAND BRUSHES FOR STEEL/STAINLESS

FEATURES

- Plastic handle scratch brush
- Long handle and shoe handle brushes

BENEFITS

- Ergonomic handle
- Crimped wire for longer life
- Wires are wrapped up and around the metal post so they never come out
- Curved face for hard-to-reach places
- Narrow brush allows access into tight areas and slots
- Steel scratch brushes are made with a high-carbon, brass-coated steel; stainless steel is made with a 304L stainless



SIZE	STD. PKG.	APPLICATION	PART NO.
Scratch Brush 3 x 19 Long Handle	12	Carbon	66252833948
Scratch Brush 3 x 19 Long Handle	12	Stainless	66252833950
Scratch Brush 4 x 16 Shoe Handle	24	Carbon	66252833949
Scratch Brush 4 x 16 Shoe Handle	24	Stainless	66252833951
Scratch Brush Plastic Handle	24	Carbon	66252833954
Scratch Brush Plastic Handle	24	Stainless	66252833953
Inspection Brush 3 x 7	36	Stainless	66252833952

STAINLESS

STEEL/METAL





Micro-Fiber Cloths

- A micro-fiber is a single fiber with a thickness less than a human hair that has been split 16 times and woven into various products.
- The surface area of a micro-fiber product is increased over 15 times, creating millions of spaces between the fibers which trap dirt, grime or liquids, making this product one of the most absorbent materials.
- Use these micro-fiber cloths dry for general cleaning.
- To remove spills, stains or grime, lightly dampen the cloth for best results.
- All micro-fiber cloths can be used with or without chemicals.
- Micro-fiber cloths can be washed up to 300+ times without losing cleaning and trapping abilities.
- Clean often for best results.
- They save you labor, time, and additional costs of multiple cleaning products and chemicals.

DESCRIPTION	COLOR	STD. PKG.	PART NO.
Micro-Fiber Cleaning Cloth (Blue)			
Used for general-purpose wet or dry applications. Works best when sprayed with a light water mist to deep clean.			
16" x 16" Cleaning Cloth	Blue	20	07660705300
Micro-Fiber Dry Tack Cloth (Red)			
This woven terry cloth has a low profile to resist snagging and help pick up embedded debris. It is used in dry tack applications.			
16" x 16" Dry Tack Cloth	Red	20	07660704025
Micro-Fiber Polishing Cloth (Yellow)			
Streak-free cleaning of mirrors, optical lens and highly-polished items.			
16" x 16" Polishing Cloth	Yellow	20	07660705301



Black Lambswool Polishing Pads

- Designed to repair clearcoat finishes, these pads are 100% natural lambswool which has the densest pile of any material.
- They are well-balanced and more durable than conventional pads.
- Fibers can be compressed and still recover their natural shape.
- Because of the denser pile surface, these pads distribute and apply material evenly and consistently.
- Available in 3" – 5" diameters with a 3/4" nap to attach to a hook and loop back-up pad.

DESCRIPTION	STD. PKG.	PART NO.
Black Lambswool Polishing Pads		
3" Pad with Loop – 3/4" nap	500	63642503670
4" Pad with Loop – 3/4" nap	250	63642503671



Norton Professional High Heat Tape

- Designed for maximum performance and clean release on multiple surfaces.
- These high quality masking tapes are ideal for conditions that include exposure to the high heat curing temperatures found in automobile, truck, bus and other transportation assembly operations, as well as aerospace manufacturing applications where a conformable, clean release masking tape is required.
- Available in bulk, accordion-wrapped for protection and work site stocking.

SIZE	STD. PKG.	PART NO.
Norton Professional High Heat Tape		
3/4" x 60 yards	48	07660721948
1" x 60 yards	36	07660721949
1-1/2" x 60 yards	24	07660721950
2" x 60 yards	24	07660721951

PACKED IN SLEEVES, WITH 4 SLEEVES TO A CASE



Norton Pro Contractor Grade Tape

- A general-purpose masking tape that offers both economy and versatility for a variety of materials and applications.
- Norton Pro Contractor Grade masking tape provides a clean release up to 3 days.
- Use for general paint masking, hanging protective plastic, holding drop cloths in place and other general-purpose masking, bundling, and sealing jobs where the tape will be removed when the job is complete.
- Not intended for critical paint applications.
- Limit exposure to UV light for extended periods.
- Extended exposure to UV light could result in difficult removal from the surface.

SIZE	STD. PKG.	PART NO.
Norton Pro Contractor Grade Tape		
3/4" x 60 yards	48	07660721944
1" x 60 yards	36	07660721945
1-1/2" x 60 yards	24	07660721946
2" x 60 yards	24	07660721947

BULK PACKED AS INDIVIDUAL ROLLS



Norton Blue Core 14 Day Tape

- Our premium paint masking tape has a specially formulated adhesive system that provides optimum low- to medium-tack adhesion and clean removal from a variety of surfaces, for up to 14 days.
- Norton Blue Core masking tape can be used indoors or out.
- The crepe paper backing is designed to enable easy unrolling and to minimize slivering.
- It delivers very sharp, clean edges on smooth- to moderately-textured surfaces.

SIZE	STD. PKG.	PART NO.
Norton Blue Core 14 Day Tape		
3/4" x 60 yards	48	07660721952
1" x 60 yards	36	07660721953
1-1/2" x 60 yards	24	07660721954
2" x 60 yards	24	07660721955

BULK PACKED AS INDIVIDUAL ROLLS

Coated Abrasive Grit Comparison Chart

AVERAGE PARTICLE SIZE IN MICRONS	GRADING SYSTEMS (OTHER THAN EMERY)			EMERY PRODUCTS
	CAMI	FIPA	JIS	
5.0	—	—	—	—
6.0	—	—	3000	—
6.5	1200	—	2500	4/0
8.4	—	P2500	—	—
8.5	—	—	2000	—
9.2	1000	—	—	3/0
10.3	—	P2000	—	—
10.5	—	—	1500	—
12.2	800	—	1200	—
12.6	—	P1500	—	—
15.0	—	—	—	—
15.3	—	P1200	1000	—
16.0	600	—	—	2/0
18.3	—	P1000	800	—
19.7	500	—	—	0
20.0	—	—	—	—
21.8	—	P800	—	—
23.6	400	—	600	—
25.0	—	—	—	—
25.75	—	P600	—	—
28.8	360	—	500	—
30.0	—	P500	—	—
35.0	—	P400	400	—
36.0	320	—	—	—
40.0	—	—	360	—
40.5	—	P360	—	—
44.0	280	—	—	1
45.0	—	—	—	—
46.2	—	P320	320	—
50.0	—	—	—	—
52.5	—	P280	280	—
53.5	240	—	—	—
55.0	—	—	—	—
58.5	—	P240	—	—
60.0	—	—	240	—
64.0	—	—	—	2
65.0	—	P220	220	—
66.0	220	—	—	—
78.0	180	P180	180	—
79.0	—	—	—	3
93.0	150	—	150	—
95.0	—	—	—	FINE
97.0	—	P150	—	—
116.0	120	—	120	—
127.0	—	P120	100	—
136.0	—	—	—	MEDIUM
141.0	100	—	—	—
156.0	—	P100	—	—
189.0	—	—	—	COARSE
192.0	80	—	80	—
197.0	—	P80	—	—
260.0	—	P60	—	—
268.0	60	—	60	—
326.0	—	P50	50	—
341.0	—	—	—	EX. COARSE
351.0	50	—	—	—
412.0	—	P40	40	—
428.0	40	—	—	—
524.0	—	P36	—	—
535.0	36	—	36	—
622.0	—	P30	—	—
638.0	30	—	30	—
715.0	24	—	—	—
740.0	—	P24	24	—
905.0	20	—	—	—
984.0	—	P20	20	—
1320.0	16	—	16	—
1324.0	—	P16	—	—
1764.0	—	P12	—	—
1842.0	12	—	—	—

Backing Types

Backings are the base for the abrasive minerals and, combined with the adhesive bond, support and anchor the abrasive mineral. The backings used in the manufacture of coated abrasives are:

Paper

Due to the fine surface of paper, a consistent finish is produced. Paper weights include *A, B, C, D, E* and *F* weights with *A* being the lightest and most flexible and *F* being the heaviest and least flexible. *A, B, C* and *D* weight papers are used for hand sanding and light mechanical operations in the form of sheets, PSA (pressure sensitive adhesive) and hook and loop discs and sheet rolls. *E* and *F* weight papers are primarily used for more aggressive mechanical operations in the form of belts and discs.

Cloth

Cloth backings used for coated abrasives are identified by weight. Cloth backings are filled or “finished” with a variety of materials (glues or resins) to create various backing characteristics, most notably flexibility. Several cloth types are used: cotton, polyester, polyester/nylon and polyester/cotton blends, and rayon.

There are three basic weights of cloth: J-weight or “jeans” is the lightest and most flexible. X-weight or “drills” is a heavier cloth that ranges in flexibility, strength and durability and is used on the broadest range of applications. Y-weight is a heavyweight drills cloth used on heavy-duty, high stock removal operations.

Fiber

Vulcanized fiber (cotton fibers which are chemically treated and then pressed under temperature and pressure to form a very durable backing) is used exclusively as the backing for resin fiber discs.

Film

Polyester film backing comes in 3 mil. and 5 mil. thicknesses, which have high strength and surface smoothness. They are used primarily in disc and roll applications requiring consistent surface finish.

Bond Types

An adhesive bond system is required to secure the abrasive mineral to the backing. All coated abrasive products are made with a two stage bonding process, the *make coat* and the *size coat*.

The *make coat* is the first layer of bond applied to the backing. The make coat provides the adhesive base between the abrasive mineral and the backing.

The *size coat* is the second coat, which is applied over the abrasive mineral and make coat to anchor the abrasive mineral and provide the desired physical strength of the finished product.

Glue, urea resin, and phenolic resin are the three basic bonding agents most commonly used. There are many size coat and make coat combinations, such as *glue over glue, urea over glue, and resin over resin*. *Glue over glue* is the most flexible bond while *resin over resin bond* is moisture-resistant, harder, less flexible, heat-resistant and has superior grain retention.

Coating Types

There are two types of abrasive coatings used in the manufacturing of coated abrasives: *open coat* and *closed coat*.

Open Coat

With an open coat, 50% to 75% of the surface is covered by abrasive grain. There are evenly spaced voids between the particles of grain, helping reduce the effect of loading caused by wood dust or metal particles.



OPEN COAT
(1/3 LESS GRAIN THAN CLOSED)

Closed Coat

With a closed coat, the entire surface is covered with abrasive grain, with no voids between the particles. This is the most typical coating, permitting the greatest degree of stock removal and longest product life.



CLOSED COAT

How to Read an Abrasive Product Specification

Conventional Grinding Wheels												
32A		46		I		8		V		BE		
ABRASIVE			GRIT SIZE			GRADE			STRUCTURE	BOND TYPE	NORTON SYMBOL	
ALUMINUM OXIDE	CERAMIC ALUMINUM OXIDE	SILICON CARBIDE	ZIRCONIA ALUMINA	COARSE	MEDIUM	FINE	SOFT	MEDIUM	HARD	RELATIVE GRAIN SPACING	Resin = B Shellac = E Plastic = P Rubber = R Vitrified = V	Designates a variation or modification to bond.
23A	3SGP	37C	4NZ	12	30	80	D	I	Q	DENSE	2	
25A	3SGP	39C	4ZF	14	36	90	E	J	R	↑ ↓	4	
32A	3SGR	Crystolon	5ZF	16	46	100	F	K	S		5	
32AC (blend)	5SG		AZ (blend)	20	54	120	G	L	T		6	
38A	BRG		BlueFire	24	60	150	H	M	U		8	
48A	SG		Charger		70	220		N	V		12	
53A	SXG		(blend)					O	Y		16	
55A	NorZon Plus		NZ					P	Z		19	
57A	(blend)		NZC (blend)								25	
U57A	NQ Quantum		NZIII								28	
64A			NZIV									
86A			NorZon									
90A												
FabCut												
Gemini												
Alundum												

Coated Abrasives							
R		9		8		1	
BACKING / BOND		PRINCIPAL ABRASIVE		COATING		RANDOM	
A = Lightweight Paper (A-D wts.) excluding Waterproof		1 = Aluminum Oxide		1 = Openkote		Designates different products within the same product group.	
F = Fiber		2 = Aluminum Oxide		2 = Closekote			
H = Heavy Paper / Resin Bond (E and F wts.)		3 = Layered Aluminum Oxide		3 = Openkote			
K = Cloth / Glue Bond (J and X wts.)		4 = Silicon Carbide		4 = Closekote			
PB = B-wt. Paper with Resin Bond and Latex		5 = Garnet		5 = Openkote			
Q = Various (e.g. Screen-Bak and Film)		6 = Crocus & Emery		6 = Closekote			
R = Cloth / Resin Bond (H, J, X and Y wts.)		8 = Zirconia Alumina		7 = Openkote			
T = Waterproof Paper (A, C wts.)		9 = Norton SG - Ceramic Aluminum Oxide		8 = Closekote			
U = Lightweight Waterproof Paper / Resin Bond				9 = Openkote			
				0 = Closekote			

Product Warranty

WARRANTY – Norton warrants the products in this catalog to be free from defects in material or workmanship for a period of one year from the date of purchase. Norton's sole obligation under this warranty shall be to repair or replace, at Norton's option, any product which is non-conforming provided any such product failure was not caused by a subsequent modification of the product, misuse or a failure to follow any applicable instructions for the product.

EXCEPT FOR THE FOREGOING, NORTON EXPRESSLY DISCLAIMS ALL OTHER GUARANTIES AND/OR WARRANTIES, EXPRESS OR IMPLIED, INCLUDING THE WARRANTIES OF MERCHANTABILITY AND FITNESS FOR A PARTICULAR PURPOSE.

Product Quality Complaints

All product quality complaints should be submitted to your local Norton Distributor.

Liability Limitation

NORTON'S LIABILITY FOR ANY LOSS OR DAMAGE ARISING OUT OF OR RESULTING FROM THE USE OF THE PRODUCT SHALL NOT EXCEED THE PURCHASE PRICE THEREOF, REGARDLESS OF WHETHER SUCH LIABILITY ARISES IN CONTRACT, TORT (INCLUDING WITHOUT LIMITATION NEGLIGENCE OR STRICT LIABILITY), OR OTHERWISE, AND IN NO EVENT SHALL NORTON BE LIABLE FOR INDIRECT, SPECIAL, INCIDENTAL OR CONSEQUENTIAL DAMAGES OF ANY KIND. NO REPRESENTATIVE OF NORTON, NOR ANY OF NORTON'S DISTRIBUTORS OR DEALERS, IS AUTHORIZED TO MODIFY THIS WARRANTY OR ISSUE ANY WARRANTY REGARDING THE PRODUCTS IN THIS CATALOG.

Trademarks

All trademarks used in these pages are trademarks of Saint-Gobain Abrasives unless otherwise indicated.

3X™	FLEXDRUM™	NORKUT™	RESCUE RUNNER™
ABRASIVE CONNECTION EXPRESS™	FLEXEDGE™	NORGRIP®	RIGHTCUT™
ABRASOTEX™	FURIOSOTM	NORLOK™	SAABA™
ADALOX®	GEMINI®	NORPOR®	SAND-O-FLEX™
ALUNDUM®	G-FORCE™	NORTON®	SANDWET™
AERO-JET™	GLOBAL™	NORTON CLIPPER™	SCREEN-BAK®
AMPLEX®	GREEN FLIPPER™	NORTON DESIGN®	SHURSTIK™
AVOS®	GREENLYTE™	NORTON SG®	SILVER EAGLE®
AZTEC®	GRIND-O-FLEX™	NORZON®	SOFTTOUCH®
AZTEC II®	INDIA®	NORZON BLUEFIRE®	SPEED CHANGE™
BEAR-TEX®	JOBPACK™	NORZON PLUS®	SPEED-LOK®
BLACK ICE®	LIGHTNING®	PACESETTER®	STICK & SAND®
BLAZE™	LONG LIFE™	PARADIGM™	TARGA®
BLUE-BAK™	MERIT®	PLYWELD®	THE SEE-THRU SYSTEM™
BLUEFIRE™	METALITE®	POLYBOND™	TUFBAK®
CHARGER™	MINI-DEX™	POWERFLEX®	TWINFIBER™
CLEAR CREEK™	MSL®	POWERLOCK®	TWINSTAR™
CLOSEKOTE®	MULTI-AIR®	POWERSTRIP™	U-DEX-IT™
CRYSTOLON®	MULTI-AIR® PLUS™	PURESAND®	UNIVEL®
DRYICE®	MULTI-OILSTONE®	QUANTUM™	USB™
DUO®	MULTISAND™	QUADRO-FIT PRO™	VORTEX®
DURITE®	THE MUSCLE BEHIND THE MACHINE®	RAILCUT™	WINTER®
EDGER™	NANOZYTE™	RAPID BLEND™	WOODSAND™
EZ CHOICE™	NEON™	RAPIDCUT™	AND OTHERS
E-Z FLEX®	NEX™	RAPID FINISH™	
FAB CUT™	NO-FIL®	RAPID PREP™	
FASTCUT™	NORAX®	RAPID STRIP™	
	NORBIDE®	RED HEAT®	

Safety – It’s the Smart Thing to Do



SPEEDS

Check machine spindle speed and speed listed on machine against safe maximum operating speed marked on the grinding wheel. Do not overspeed the wheel.



FACE PROTECTION

Always wear government-approved face and eye protection when using abrasive products.



SAFETY GLOVES

Grinding applications are conducted in harsh environments. The use of proper fitting gloves is recommended.



WHEEL GUARD

Always use the wheel guard as supplied by the machine manufacturer, in the proper position.

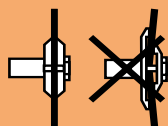

FLANGES

When mounting most grinding wheels, use flanges of equal diameter and bearing surface. For exceptions, see ANSI B7.1.



HEARING PROTECTION

Use of abrasive products may create elevated sound levels. Hearing protection must be worn where required.



SAFETY GUIDES, MSDS AND WHEEL WARNING MESSAGES

Before using any abrasive materials, READ:

- The Safety Guides
- Wheel Warning Messages
- Material Safety Data Sheets (MSDS)

Norton provides information pertaining to the safe use of all products. Please take the time to read it carefully. Contact suppliers of the workpiece and abrasive materials for copies of the MSDS if one is not readily available. Norton abrasives MSDS can be obtained on www.nortonabrasives.com



DUST PROTECTION

Exposure to dust generated from workpiece and/or abrasive materials can result in lung damage and/or other physical injury.

Use dust capture or local exhaust as stated in the MSDS. Wear government-approved respiratory protection and eye and skin protection.

Failure to follow this warning can result in serious lung damage and/or physical injury.

This is a general dust warning and does not cover specific situations. For more information, refer to the MSDS dust warning provided with your products, and workpiece.



WARNING

This warning icon appears on our products and packaging. It is intended to draw your attention to the specific safety warning practices outlined after it.



PISTOL GRIP AIR SANDER

A DEADLY EQUATION

Pistol Grip Air Sander + Grinding Wheel = Certain Injury!

- Never use a high speed air sander as a portable grinder
- Use only sanding discs specifically designed for sanders
- Because the speed of these sanders far exceeds the maximum rated speeds for grinding wheels, a potentially lethal wheel breakage may occur

Breakages/Personal Injury

In the event of on-machine breakage of Norton abrasive products, call your local Norton distributor immediately. Whether involving personal injury or not, the abrasive user should leave the equipment and other evidence undisturbed until a Norton sales representative has been notified and conducts an investigation. Prompt action on the part of abrasive users, distributor, and Norton sales personnel is important to ensure swift determination of the breakage cause and to guard against recurrence.

Safe Operating Practices

Safe operating practices must be part of every grinding wheel user's operation. The greatest efficiency and lowest overall abrasive cost can be realized only if proven care and use techniques become standard practice.

- Be sure to read any safety material/guidelines provided with the abrasive product.
- Always check the wheel for cracks or damage before use.
- Always properly maintain your machine; especially governors on pneumatic machines and linkage on floorstand machines.
- Never use the incorrect air, hydraulic or electric power supply.
- Never mount grinding wheels directly on electric motors.
- Never mount grinding wheels on the wrong size machine for the grinding wheel.
- Before mounting the wheel, use a tachometer to measure the spindle speed.
- Ensure the mounting flanges, backplate or adapter supplied by the machine manufacturer are used and kept in good condition. ANSI Safety Requirement B7.1 provides wheel mounting requirements. Check mounting flanges for equal and correct diameter and use blotters when supplied.
- Always mount, true and dress the wheel in conformance with the guidelines published in the ANSI Safety Requirements B7.1.
- Ensure the correct wheel guard is in place before starting the wheel. Allow the wheel to come up to full operating speed before starting to grind for a minimum of one minute, and stand out of the plane of rotation.
- NEVER use a high speed air sander as a portable grinder.
- NEVER use grinding wheel with a rated speed less than that of the grinder.
- NEVER exceed the maximum operating speed marked on the wheel being used. The following formula may be used to calculate wheel speed:

$$SFPM = \text{Spindle Speed in RPM} \times \text{Wheel Dia. in inches} \times .262$$
- Avoid dropping or bumping the wheel.
- When not using the wheel, store the wheel in its original packing materials. This protects the wheel from chips and cracking, as well as provides easy identification of the wheel.

For more information on product safety, ask your Norton distributor for these publications:

- "Primer on Grinding Wheel Safety" (form 474) (available on www.nortonabrasives.com)
- Portable Grinding Safety (form 1406)
- ANSI B7.1 "Safety Requirements for the Use, Care and Protection of Abrasive Wheels"
- ANSI B7.7 "Safety Requirements for Abrading Materials with Coated Abrasive Systems"
- OSHA and literature provided by the grinding wheel and machine manufacturer
- Material Safety Data Sheets (available on www.nortonabrasives.com)
- Other applicable regulations
- Or contact the Saint-Gobain Product Safety Department at telephone 508-795-2317, fax 508-795-5120, or your Norton representative

AVOID BODILY CONTACT WITH AN ABRASIVE PRODUCT

Small text describing safety instructions for handling abrasive products, including warnings about eye contact, skin contact, and proper disposal methods.



PLAY IT SAFE AT THE WHEEL

Small text providing additional safety tips for grinding operations, such as using proper techniques and maintaining equipment.



Safety on the Web

As part of Saint-Gobain Abrasives' ongoing commitment to safety, each month a new safety article is published on the Norton website. Topics include proper abrasive storage, equipment maintenance, proper wheel mounting, using blotters, ring testing a grinding wheel, wheel dressing and much more. Visit the Norton website at www.nortonindustrial.com and check the "News" section for the newest article. Or click on "Safety" to review our archived safety articles.

www.nortonabrasives.com

Call your local Distributor for our safety DVD:

"Safety, It's The Smart Thing To Do!"



It is the user's responsibility to refer to and comply with ANSI B7.1 and B7.7

Starting a Grinding Wheel

ANSI's Procedure for Starting an Abrasive Wheel

In the past several years we have heard of wheel breakages and accidents involving abrasive wheels breaking on start-up. This article is designed to remind users of the proper procedure when starting a machine with a new abrasive wheel mounted on it, or starting a machine after the machine and wheel have been stored for a period of time, or remounting a wheel. ANSI B7.1-2000 requires the following procedure when starting a newly mounted grinding wheel.

9.8 Starting the Wheel (Requirements)

All abrasive wheels shall be run at operating speeds with the safety guard in place or in a protected enclosure for at least one minute before applying work. During this time no one shall stand in front of or in line with the wheel. (See section 4, for safety guard requirements.) This provision shall apply each time one of the following conditions occur: a) a new wheel has been mounted; or b) a used wheel has been remounted.

E 9.8 Starting the Wheel (Explanatory Information)

An abrasive wheel may be damaged in shipment or storage, or the wheel may be subjected to improper, excessive stresses during mounting. Wheels which have been damaged or are under excessive stress, are likely to fracture within the first minute of rotation at operating speed. While this procedure is most important at the time when an abrasive wheel is mounted or remounted, damage may also occur to a wheel during a shut down of the machine on which it is mounted. The user should evaluate the circumstances and length of machine shut down to determine additional times that the operating rule should be followed.

Improper wheel mounting is a major cause of wheel breakages. Always use proper mounting procedures as outlined in ANSI B7.1, machine manufacturer's instructions and those supplied with the abrasive wheel. Be safe, know and follow the rules!

For additional information on this topic or any other abrasive product safety information, please review ANSI, OSHA and literature provided by the grinding wheel and machine manufacturer.



What You Should Know About Grinding Wheel Guards

Reports indicate customers in the grinding wheel industry break approximately one grinding wheel per day. Most of these breakages are caused by human error, do not result in personal injury, and generally go unreported. Grinding wheel guards are one of the key components in keeping these grinding wheel mishaps from becoming a personal injury.

Dangerous Conditions Caused by the Ineffective Use of Grinding Wheel Guards:

- Incorrect:** Cup wheels such as Type 6 and 11 used on a portable angle grinder with a Type 27, 28 and 29 depressed center grinding wheel guard.
- Explanation:** While a properly adjusted Type 27, 28 and 29 guard works with a Type 27, 28 or 29 wheel, it offers little or no protection with a Type 6 or 11 cup wheel. The cup wheel "hangs" below the guard meant for a Type 27, 28 or 29 wheel and in the event of a wheel breakage; it offers little or no protection.
- Incorrect:** Type 01 straight cut-off wheels used on a portable angle grinder with a Type 27, 28 or 29 depressed center grinding wheel guard.
- Explanation:** Type 27, 28 and 29 guards are open on the bottom to allow for side grinding with raised hub/depressed center wheels. When side grinding with the Type 27, 28 or 29 wheel, the workpiece acts as a portion of the guard, protecting the operator in the event of a wheel breakage. Cut-off wheels are not designed for use on their side and must be used on their outer periphery only. Guards for cut-off wheels must cover a full 180° area on all sides of the wheel. When using a cut-off wheel with a Type 27, 28 or 29 guard, there is no guard on one side of the wheel, protecting the operator in the event of a wheel breakage. Do not use cut-off wheels on angle grinders without the proper guard.
- In Summary:** Grinding wheel guards designed for one type of machine used on another type of machine, or the wrong guards for the type of wheel, are dangerous.

Ineffective Grinding Wheel Guards:

- The most ineffective guard is the one that has been removed from its machine and is sitting in storage. The removal of a wheel guard on a machine in operation is not only extremely dangerous, but illegal.
- Do not alter or cut back a guard. Using a damaged or altered wheel guard is extremely dangerous to the safety of the operator and bystanders. Guards that are altered, cracked, deformed, bent, or severely worn must be replaced. Once a guard has been damaged, it might become ineffective in a future wheel breakage. If a wheel breakage occurs, the guard must be inspected and if there is any sign of damage, the guard must be replaced.
- Machines with missing wheel guard fasteners are also very dangerous. Sometimes during routine machine maintenance the guard fasteners are damaged and not replaced when the machine is reassembled. During a wheel breakage, the missing fasteners might allow the guard to move, become unattached from the machine or open, exposing the operator to being injured by the guard or not containing the wheel fragments in the event of a wheel break.
- A guard made of paper, tin, cloth, wood or other materials not designed to contain wheel fragments might fail when struck by a wheel fragment. Always use the guard that is recommended for the machine and its operation. Never paint or disguise the wrong material for a proper guard.

Guards Not Properly Adjusted:

- A wheel guard that is set too high on a portable angle grinder will allow the wheel to hang below the guard. This improper setting may render the guard useless in the event of a wheel breakage.
- The wheel guard of a portable machine positioned improperly. A guard used on a portable machine must be positioned so it is located between the operator and the grinding wheel. Also, bystanders must not be positioned in front of the wheel guard's open area.
- Failure to maintain the proper setting of the adjustable tongue guard (AKA spark arrester) on bench, pedestal, or small floor stand grinder. OSHA requires a maximum clearance of 1/4" between the grinding wheel and the tongue guard. If a wheel breakage should occur, maintaining the proper distance will help to contain the wheel fragments and reduce the probability of an injury.

Shelf Life and Proper Storage of Grinding Wheels

It has always been Saint-Gobain Abrasives recommendation that resinoid bonded grinding wheels be used within 2 years from the date of manufacture. This recommendation assumes that resinoid bonded grinding wheels have been stored under ideal storage conditions. It might be true that under ideal storage conditions resinoid bonded grinding wheels can survive without any degradation in strength for well over two years. However, it is always wise to suspect any wheels over two years old and have them reinspected or re-speed tested to determine if there has been any degradation in strength. If the wheels are stored under less than ideal conditions, they might have a much shorter shelf life depending upon the severity of storage conditions. These same comments also apply to rubber and shellac bonded grinding wheels.

As for vitrified grinding wheels, the shelf life is less influenced by humidity and adverse storage conditions as compared to resinoid, rubber or shellac, but even vitrified grinding wheels do not have an infinite shelf life. The best procedure and the best rule of thumb is to have any wheel that is two years old or older re-speed tested and reinspected to ensure it is fit for use. The procedure for having this done and the charges will be explained by our Customer Service Department, but the cost of shipping as well as the cost of reinspection is the customer's responsibility. Also, any wheels rejected or otherwise lost in the reinspection process will also be the responsibility of the customer.

Keep in mind, however, that this procedure is good to verify the reliability of a product but must not be performed until you are ready to consume the wheel. If wheels are sent back after the two year time frame for reinspection and re-testing and then put back on the shelf, there is no telling how long they will be fit for use after that last inspection. Therefore, these wheels must be consumed as soon as is practical.

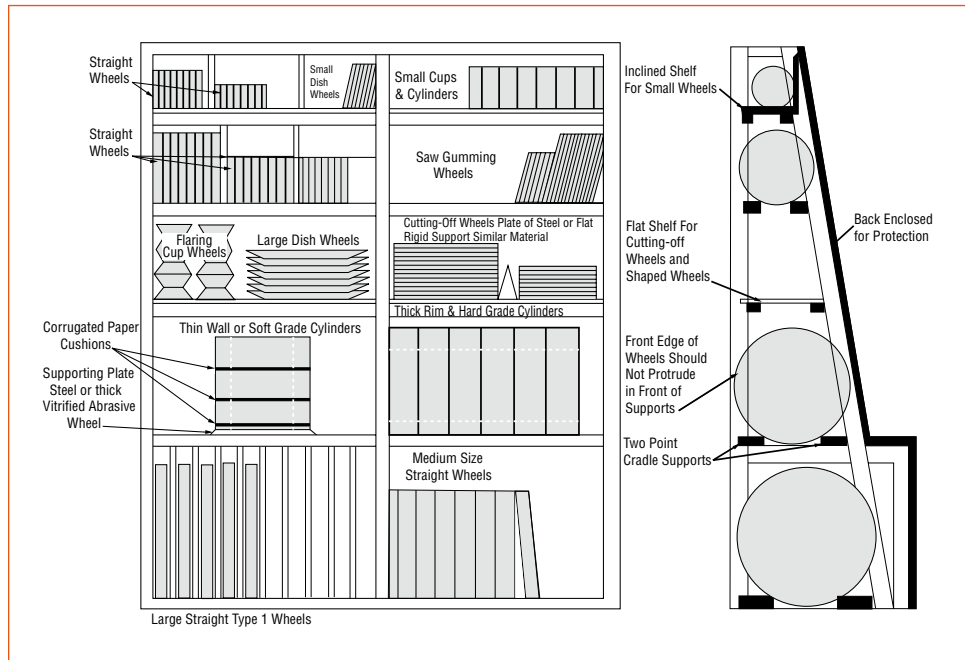

How to Perform a Ring Test on a Grinding Wheel

One method of grinding wheel inspection is called ring testing. OSHA, ANSI and the grinding wheel manufacturers require this method of grinding wheel inspection. It must be performed BEFORE the wheel is mounted on a grinding machine. Ring testing depends on the damping characteristics of a cracked wheel to alter the sound emitted when the wheel is tapped lightly. It is subject to interpretation by the inspector and is primarily applicable to vitrified bonded wheels. To perform the ring test, wheels should be tapped gently with a light nonmetallic implement, such as the handle of a screw driver for light wheels, or a wooden mallet for heavier wheels.

- Tap wheels about 45 degrees each side of the vertical line and about 1" or 2" from the periphery. Rotate the wheel 45 degrees and repeat the test.
- Large and thick wheels may be given the ring test by striking the wheel on the periphery rather than the side of the wheel.
- A sound and undamaged wheel will give a clear tone. If cracked, there will be a dead sound and not a clear ring and the wheel should not be used.
- Wheels must be dry and free of sawdust when applying the ring test, otherwise the sound may be deadened. The ring test is not applicable to certain wheels because of their size, shape or composition.

Proper Grinding Wheel Operating Speeds and Safety!

As abrasive wheel producers have known for many years, most grinding wheel breakages and injuries are caused by one major oversight. That oversight is operating a grinding wheel in an over-speed condition. A grinding wheel should never be operated at speeds greater than the wheel's rated speed.

- Never use a grinding wheel with a rated speed less than that of the grinder
- Never mount grinding wheels on sanders (Pistol Grip Air Sanders)
- Never mount grinding wheels directly on electric motors
- Never mount grinding wheels on the wrong size machine for the grinding wheel
- Always properly maintain your machine: especially governors on pneumatic machines and linkage on floorstand machines
- Never use the incorrect air, hydraulic or electric power supply
- Never use the improper speed setting on a machine

What you might not be cognizant of is that slight over-speed can cause damage to a wheel. If an operator continues to use this damaged wheel, it might break. In a reinforced wheel for example, cracks might form, be forced open and jam or catch the wheel on the workpiece resulting in a wheel breakage. The use of a 9" Type 27 Wheel on a 7" angle grinder is very dangerous! Normal stresses that occur during grinding along with the additional stress caused by over-speed are additive. The act of operating a wheel in a slight over-speed condition is very dangerous. We must understand and communicate this danger.



One of the major forces at work on a grinding wheel is called "centrifugal force." To demonstrate this force take a piece of string and tie a small weight to one end. Hold the other end of the string so the weight will travel in a circle. Rotate the weight and you will feel a pull on the string. The weight tries to fly off in a straight line, but the string holds it and compels it to travel in a circle. This pull on the string is called "centrifugal force." Warning: If you attempt this experiment take all the proper precautions related to the object used to avoid injury to yourself or others.

If you swing the weight at a speed of 50 revolutions per minute (RPM) and could measure the pull on the string at this speed, then increase the swing to 100 revolutions per minute and again measure the pull, you would find the pull was not merely two times greater, but was actually four times greater than it was at one half the speed. Therefore, the force increases exponentially with the speed or RPM.

Centrifugal force increases in proportion to the square of the velocity. Think again of the weight and the string. We find that the square of 50 is 2,500, ($50 \times 50 = 2,500$); and the square of 100 is 10,000, ($100 \times 100 = 10,000$). As 10,000 is four times as great as 2,500, so is the pull on the string at 100 revolutions per minute four times as great as it was at 50 revolutions per minute.

Centrifugal force applies to grinding wheels in the same manner as the weight to the string. Increasing the RPM or speed beyond the maximum safe operating speed (MOS) might be more dangerous than might be expected. Placing and operating a 9" Type 27 grinding wheel with a maximum operating speed of 6,600 RPM on a 5" right angle grinder with a rated speed of 10,000 RPM represents an over-speed of approximately 1.515 times the wheel's designated speed. The resulting rotational stress caused by the centrifugal force would be approximately 2.3 times greater than the maximum allowed. Add this additional stress to the stresses that occur during normal grinding and even the strongest wheel might break.

In short, NEVER over-speed a grinding wheel. Always compare the speed marked on the wheel or package to make sure the machine's speed is at, or below, the speed or MOS of the grinding wheel. Speed can kill. NEVER over-speed a grinding wheel.



Conversion Table – Wheel Speeds

REVOLUTIONS PER MINUTE FOR VARIOUS DIAMETERS OF GRINDING WHEELS TO GIVE SURFACE SPEED IN FEET PER MINUTE AS INDICATED
(FOR WHEEL MARKING PURPOSES THE CALCULATED RPM FIGURES LISTED BELOW ARE ROUNDED OFF TO THE NEXT 5)

Diameter of Wheel in Inches	Surface Speed in Feet Per Minute (SFPM)																				
	4,000	4,500	5,000	5,500	6,000	6,500	7,000	7,500	8,000	8,500	9,000	9,500	10,000	12,000	12,500	14,200	16,000	16,500	17,000	19,685	20,000
1	15,279	17,189	19,098	21,008	22,918	24,828	26,737	28,647	30,558	32,467	34,377	36,287	38,196	45,836	47,745	54,240	61,116	63,025	64,935	75,190	76,395
2	7,639	8,594	9,549	10,504	11,459	12,414	13,368	14,323	15,278	16,233	17,188	18,143	19,098	22,918	23,873	27,120	30,558	31,510	32,465	37,595	38,195
3	5,093	5,729	6,366	7,003	7,639	8,276	8,913	9,549	10,186	10,822	11,459	12,096	12,732	15,278	15,915	18,080	20,372	21,010	21,645	25,065	25,465
4	3,820	4,297	4,775	5,252	5,729	6,207	6,685	7,162	7,640	8,116	8,595	9,072	9,549	11,459	11,940	13,560	15,278	15,755	16,235	18,800	19,100
5	3,056	3,438	3,820	4,202	4,584	4,966	5,348	5,730	6,112	6,494	6,876	7,258	7,640	9,168	9,550	10,850	12,224	12,605	12,985	15,040	15,280
6	2,546	2,865	3,183	3,501	3,820	4,138	4,456	4,775	5,092	5,411	5,729	6,048	6,366	7,639	7,960	9,040	10,186	10,505	10,820	12,530	12,730
7	2,183	2,455	2,728	3,001	3,274	3,547	3,820	4,092	4,366	4,638	4,911	5,183	5,456	6,548	6,820	7,750	8,732	9,005	9,275	10,740	10,915
8	1,910	2,148	2,387	2,626	2,865	3,103	3,342	3,580	3,820	4,058	4,297	4,535	4,775	5,729	5,970	6,780	7,640	7,880	8,115	9,400	9,550
9	1,698	1,910	2,122	2,334	2,546	2,758	2,970	3,182	3,396	3,606	3,820	4,032	4,244	5,092	5,305	6,030	6,792	7,000	7,215	8,355	8,490
10	1,528	1,719	1,910	2,101	2,292	2,483	2,674	2,865	3,056	3,247	3,438	3,629	3,820	4,584	4,775	5,425	6,112	6,300	6,495	7,520	7,640
12	1,273	1,432	1,591	1,751	1,910	2,069	2,228	2,386	2,546	2,705	2,864	3,023	3,183	3,820	3,980	4,520	5,092	5,250	5,410	6,265	6,365
14	1,091	1,228	1,364	1,500	1,637	1,773	1,910	2,046	2,182	2,319	2,455	2,592	2,728	3,274	3,410	3,875	4,366	4,500	4,640	5,370	5,455
16	955	1,074	1,194	1,313	1,432	1,552	1,672	1,791	1,910	2,029	2,149	2,268	2,387	2,865	2,985	3,390	3,820	3,940	4,060	4,700	4,775
18	849	955	1,061	1,167	1,273	1,379	1,485	1,591	1,698	1,803	1,910	2,016	2,122	2,546	2,655	3,015	3,396	3,500	3,605	4,175	4,245
20	764	859	955	1,050	1,146	1,241	1,337	1,432	1,528	1,623	1,719	1,814	1,910	2,292	2,390	2,715	3,056	3,150	3,245	3,760	3,820
22	694	781	868	955	1,042	1,128	1,215	1,302	1,388	1,476	1,562	1,649	1,736	2,084	2,170	2,465	2,776	2,865	2,950	3,420	3,470
24	637	716	796	875	955	1,034	1,115	1,194	1,274	1,353	1,433	1,512	1,591	1,910	1,990	2,260	2,546	2,625	2,705	3,135	3,185
26	588	661	734	808	881	955	1,028	1,101	1,176	1,248	1,322	1,395	1,468	1,762	1,840	2,090	2,352	2,425	2,495	2,890	2,940
28	546	614	682	750	818	887	955	1,023	1,092	1,159	1,228	1,296	1,364	1,637	1,705	1,940	2,182	2,250	2,320	2,685	2,730
30	509	573	637	700	764	828	891	955	1,018	1,082	1,146	1,210	1,274	1,528	1,595	1,810	2,056	2,100	2,165	2,505	2,545
32	477	537	597	656	716	776	836	895	954	1,014	1,074	1,134	1,194	1,432	1,495	1,695	1,910	1,970	2,030	2,350	2,385
34	449	505	562	618	674	730	786	843	898	955	1,011	1,067	1,124	1,348	1,405	1,595	1,796	1,855	1,910	2,210	2,245
36	424	477	530	583	637	690	742	795	848	902	954	1,007	1,061	1,273	1,330	1,510	1,698	1,750	1,805	2,090	2,120
38	402	452	503	553	603	653	704	754	804	854	904	955	1,006	1,206	1,260	1,430	1,608	1,660	1,710	1,980	2,010
40	382	430	478	525	573	620	669	716	764	812	860	908	956	1,146	1,195	1,355	1,528	1,575	1,625	1,880	1,910
42	366	409	454	500	545	591	636	682	732	775	818	863	908	1,090	1,140	1,295	1,464	1,500	1,545	1,790	1,820
44	347	390	434	478	521	564	608	651	694	737	780	824	868	1,042	1,085	1,235	1,388	1,432	1,475	1,710	1,735
46	333	375	416	458	500	541	582	624	666	708	750	791	832	1,000	1,040	1,180	1,332	1,370	1,410	1,635	1,660
48	318	358	398	438	478	517	558	597	636	676	716	756	796	956	995	1,130	1,272	1,315	1,350	1,565	1,590
53	288	324	360	395	432	468	503	539	576	612	648	683	720	864	900	1,025	1,152	1,189	1,225	1,420	1,440
60	255	287	319	350	387	414	446	478	510	542	574	606	638	774	795	905	1,020	1,050	1,080	1,255	1,275
72	212	239	265	291	318	345	371	398	424	451	477	504	530	637	665	755	849	875	905	1,045	1,060

For intermediate diameters not listed use the formula listed in Section 1.2.10 of ANSI B7.1 (SFPM = .262 x wheel diameter in inches x RPM.)
To convert meters per second (m/s) to SFPM: m/s x 196.85 = SFPM. To convert SFPM to m/s: SFPM/196.85 = m/s. To convert RPM to SFPM: Wheel Diameter x RPM x 0.262 = SFPM



POINT OF PURCHASE SOLUTIONS THAT MAKE AN IMPACT!

- **Modular design for mix and match**
- **Pre-selected product assortment for optimal category coverage by end-user machines and applications**
- **Adaptable to both wall space and free-standing spinner**



GET ACCESS TO THE INDUSTRY'S BEST SELECTION OF ABRASIVE SOLUTIONS!

Inside Sales

FOR INFORMATION, contact our inside sales team:

- Product application information/technical assistance
- Competitive product conversions
- Product availability, pricing and delivery information
- Request for on-site "no-risk" product test

PHONE: **800-962-9379** FAX: **508-795-5950**



Norton/Saint-Gobain is so confident of the superior performance of our abrasive products, as recommended for specific applications, that we invite in-plant tests against any other brand of abrasive product on the market.

- 1 The test will be conducted in the user's own plant, on their own machines, using their own workpieces.
- 2 Even if the user purchases only a minimum quantity of Norton abrasive products, the user will receive the same quantity discount as would apply to their normal production orders.
- 3 If the Norton product tested proves completely unsatisfactory, the user will receive a full refund.
- 4 If the Norton product tested performs at a lower level than the product presently in production, the user will receive an adjustment to make up the difference in performance.
- 5 The user is the final judge of performance!

Customer Service

TO PLACE AN ORDER, contact our customer service support center with:

- Customer number and contact name
- Any special shipping needs
- Complete product information:
 - 11-digit Part Number
 - Product description
 - Quantity and unit of measure
 - Price by unit of measure

EMAIL: nacustomerservice@saint-gobain.com

U.S. PHONE: **800-551-4413** FAX: **800-551-4416**

CDN. PHONE: **800-263-6565** FAX: **800-561-9490**

To ensure minimal errors and faster turnaround, using electronic media is preferred. For assistance with www.abrasiveconnection.com or EDI setup, contact us at:

Email: abrasive.connection@saint-gobain.com

Phone: **888-383-2236**



Online

This printed catalog is a great starting resource for Norton and Merit product selection. Our website is the ideal resource for a more comprehensive outline of product and application information which is continually updated with all our most current information and offers more electronic queries for deeper detail, at a click of a button.

www.nortonabrasives.com





For additional items not included in this catalog, please refer to our other market-based catalogs online www.nortonabrasives.com for availability information.

Norton Full Line of Stock Abrasive Products

CATALOG #7362

Norton Diamond, Abrasives and Equipment for the Construction Market

CATALOG #7719



Exceptional Performance to Price Ratio

- Zirconia alumina and premium aluminum oxide grain blend
- 2-3X the life of aluminum oxide wheels
- For light-to-heavy pressure jobs, on a wide range of materials



Unleash The Heat on Higher Productivity

- Premium ceramic flaps with alternating zirconia flaps
- 20% increased performance
- Type 27 flat trimmable, plastic back: blending/finishing
- Type 29 conical fiberglass back: quick stock removal



The RightCut for Every Application

- Now a RightCut product for every performance, price, and quantity need
- Long-lasting ultra-thin .040" to 3/32" thick wheels
- New stainless and aluminum wheels for the toughest jobs



New Proprietary Grain Technology

- Improved grain, bond, backings, and consistency
- Improved life and cut rate by 20%
- Ideal for grinding and finishing carbon steels, welds, alloys, and soft metals



Rapid Solutions for Surface Conditioning

- Replace many multi-step operations with one product
- Up to 35% reduction in process time on light deburring and blending operations
- 15+% performance vs. competitive conditioning products



Competitive Price without Compromise

- Merit products offer consistent performance with a low initial price
- Quality product at a great value
- Ideal for end-user unable to measure total performance



BEST

Highest Productivity – Lowest Total Cost

BETTER

Excellent Blend of Performance and Price

GOOD

Consistent Performance – Low Initial Price

www.facebook.com/nortonindustrial | www.youtube.com/nortonindustrial | www.nortonabrasives.com

Saint-Gobain Abrasives, Inc.
PO Box 15008, 1 New Bond Street
Worcester, MA 01615-0008

USA CUSTOMER SERVICE:
Phone Toll Free: 1 800 551-4413
Fax Toll Free: 1 800 551-4416

CANADA CUSTOMER SERVICE:
Phone Toll Free: 1 800 263-6565
Fax Toll Free: 1 800 561-9490

FORM #7364
© Saint-Gobain Abrasives, Inc. March 2013

